

82

DECEMBER

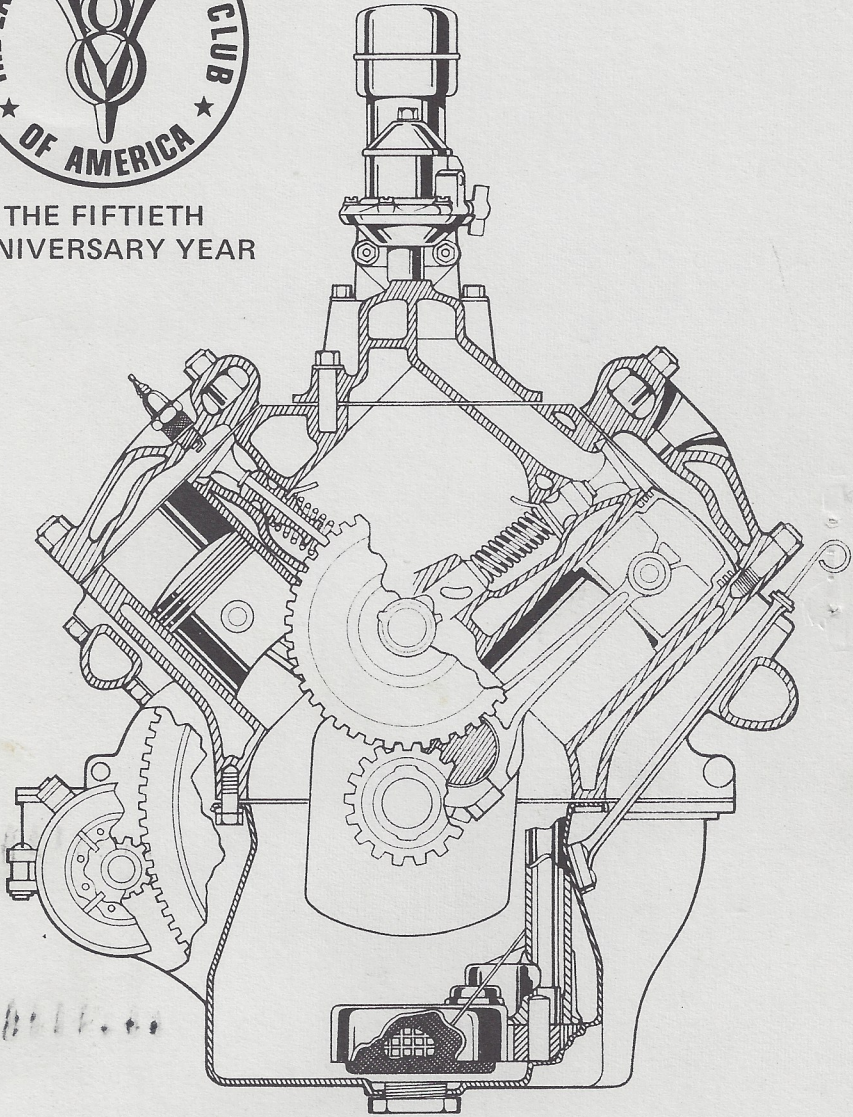

THE FIFTIETH
ANNIVERSARY YEAR



Drive Lines

The Valley 's

1982 OFFICERS

PRESIDENT	Bob Rose 362-4842
VICE PRESIDENT	John Powell (805) 647-3494
SECRETARY	Shel Harriman 398-3151
TREASURER	Bill Culp 344-0969
ACTIVITIES COMM.	Don Dupree 894-7255
	John Busk 348-0111
	Ernie Baily (805) 522-9674
HISTORIAN	Ernie Baily (805) 522-9674
DIRECTOR	Kent Lowry 368-9830
ACCESSORIES	Jim Clary 349-7261
MEMBERSHIP	Paul Kirk 886-7872
FELLOWSHIP	Al Spencer 761-1734
REFRESHMENTS	Albie Cortez 363-9460
CO-EDITORS	Larry Caplan 363-2849
	Irv Warren 780-7109 687-0656

Drive Lines

Published by

SAN FERNANDO VALLEY CHAPTER 40
of the EARLY FORD V8 CLUB of AMERICA

P.O. Box 96
RESEDA, CA. 91335

(Continued)

PRESIDENT'S MESSAGE

This is it..... our final DRIVE LINES for '82 and my closeout message to you. It has been a truly super year for THE VALLEY V-8's. You've established so many records, it's difficult to keep track, but to those of you who may not realize what you have accomplished, let me list a few of your more notable achievements:

- (1) Membership at all time high; we've hit the century mark.
- (2) Treasury at an all time high: (we are well above the thousand dollar figure)
- (3) Attendance at meetings consistently high.
- (4) Club auction, most successful we've ever had.
- (5) Outstanding technical presentations from within our membership, and guest lecturers.
- (6) Valley V-8's first overnite tour, and we had two of them. Total vintage cars: 47, total attendance: approximately 115.
- (7) Club breakfast especially geared for the ladies. Overflow crowd.
- (8) Irv Warren Garage Tour & Breakfast; overflow crowd.
- (9) Merle Norman Tour & brunch; we were allowed 50 reservations, 49 showed up.
- (10) Outstanding DRIVE LINES publications.
- (11) 20 cars and 47 V-8'ers toured to the ALL FORD PICNIC, a VALLEY V-8 record.
- (12) Our first real election of next years officers.
- (13) Sending out membership renewal envelopes has resulted in nearly 50% renewal for '83 already.

All this and we still have two events left this year. On Dec. 4th is our Christmas Party & Awards Banquet, and on Sunday December 12, we have our CHRISTMAS TREE RALLY.

As this issue of DRIVE LINES goes to press, we have no information on the CHRISTMAS TREE RALLY, as Don Durkee has been out of town, but he assures us you will receive a flyer with all the details in plenty of time....

(over)

(continued)

Nothing we have tried has failed, nothing has been marginal. It shows what we can do when we put our hearts into it. My hat is off to the greatest bunch of guys & girls I've ever had the pleasure of working with, both from within our club, and our outside support. Thanks to you each and every one.....

THE YEAR HAS COME
AND NOW IT'S PAST,

WE'VE DONE GOOD THINGS,
THE MEM'RIES LAST..

THESE RHYMES I WRITE,
I DOUBT YOU'LL MISS,

BUT BEFORE I GO,
I MUST SAY THIS....

TO EACH AND EVERY
ONE OF YOU---

A HAPPY CHRISTMAS,
AND NEW YEAR TOO.....

BOB "BURMA SHAVE" ROSE



Bob Rose



SECRETARY SEZ...

Early Fords driven to the November 7th meeting were as follows:

Ben Difatta	'36 5W coupe
Don Durkee	'36 Cabriolet
Ernie Baily	'47 pickup
Chuck Mair	'41 coupe
Dick Chutuk	'40 pickup
Harold Selson	'36 5W coupe
Jay Kerns	'30 Ford
Whitney Riebeck	'46 Fordor
Don Dupree	'46 pickup
Bill Culp	'29 roadster

Hang on to your wallets again. The money grubbers are grabbing for your green. It's the time of the year for everything from dues to booze. Ten here twenty-five there, all for a good cause, our enjoyment. Our membership has broken the 100 mark for the first time. Get your '83 dues in. Little Prez has already got some of the big names to pay up - such as Norton, Drake, Chaimberlin, Harriman, etc. Bill Culp's weather report for our treasury is "fair and warmer". We've got close to a grand in the kitty which means an open bar at the Xmas party. Remember, the Xmas party is not just for alcoholics; it's the club installation banquet, to ring in the new and wring out the old officers - I'll drink to that. Chuck Temple missed \$30 by not showing for the name tag drawing, \$35 next time, maybe at the Xmas party.

Ron Dunlop has got a deal with a cookie factory across from his shop - Jack Miles has volunteered to run our first "bake sale".

Durkee is inviting us to join in the Xmas tree chop run sponsored by the pickup club on December 12th.

John Powell gave an interesting and informative presentation on distributors. He set me straight on points. If you gap them at .016 the spark will be more advanced to begin with and as they age they will stay within tolerance longer than if you start them at .014. For years I've been looking at it bass ackwards. John also says he's been having better luck with autolite AL-7 plugs than with the familiar champion H-10 equivalents. See you at Saddle Peak!

SHEL HARRIMAN

H and G Antique Salvage

This well known salvage yard which specialized in Early Ford V8 parts was put on the auction block November 27th. Several Valley V8ers were seen looking over the meager remains of what was once a very well stocked yard. Inspection day was November 26th and I can assure those of you who didn't attend that you missed out on very little. There were some items of interest such as NOS quarter panels for 49-50 Fords, over 100 1939-40 hoods, hundreds of doors, fenders, deck lids, all in fair to poor condition.

LARRY CAPLAN

UPDATE ON EASY JACK

Those of you who attended the meeting last year where I showed a collection of slides taken at this famous Antique Junk Yard in Junction City, Kansas will want to see the latest issue of Old Cars Weekly. It seems like our hero "Easy Jack" put 200 of his 2500 cars up for auction and most sold for little over the scrap price of \$40. per car. These same jewels had prices over \$2000 last year when I inquired.

LARRY CAPLAN



The Early Ford 
CLUB OF AMERICA

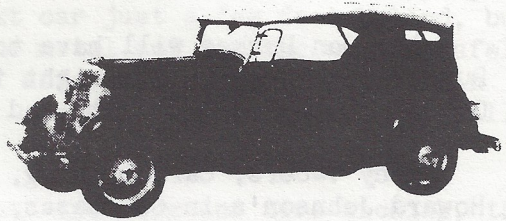

Canoga Auto Parts Co.
340-1536

21422 SHERMAN WAY
CANOGA PARK, CALIF. 91303

THIS SPACE FOR RENT

(See Bob Rose or Larry Caplan)

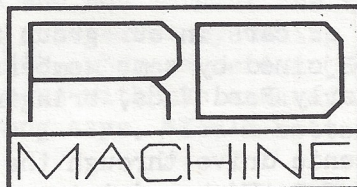

Ron Dunlop

8726 Remmet Ave
Canoga Park, CA 91304

Santa Maria Tour

Well, Don Durkee will have to go some to top his last Durkee Special, our overnight tour to Santa Maria/Guadalupe on November 13th and 14th.

Valley V-8ers, cars shining, gathered eagerly at Howard Johnson's in Calabasas, with the dark storm clouds and rain of the previous week nowhere in sight. The Spencers, driving their newly-restored woodie, came charging in at 12:58, with Ruth still clutching her bottle of Windex, determined to rid the front window of a stubborn spot, even if it meant excavating it. The good news is that she got the spot out; the bad news is that twenty three bugs of various shapes, sizes, and colors splattered against the windshield during the trip, getting Ruth so unnerved that she had to move to the back seat of the woodie for the balance of the out-
ing.

Ed and Deni Warnock, who weren't on hand at departure time, managed to catch up with the group, and bypass most of it, as they sneaked into a front position in their beautifully polished '39 convertible coupe.

First rest stop was at Ventura's historic Mission San Buenaventura, founded by Fra. Serra in 1782, where we had a quick look at the church and grounds, and an unsuccessful attempt to get the old olive press operating. Although many of the shops were open and managed to lure in the V-8ers, someone forgot to unlock the public rest rooms, creating mild hysteria in the V-8 circle, and making it necessary to make an unscheduled side trip to the Mission Plaza fig tree, which has an 18-foot circumference and branch spread of 100 feet.

The number of cars in our group increased at Ventura, when we were joined by some members of the Ventura chapter of Early Ford V-8s, bringing the car total to 14.

After a scenic drive through the hills and back roads, with Don and Mary Durkee driving at their usual break-neck speed of 73 miles an hour, followed by panting and hissing engines doing their best to keep up, the group

climbed up the last hill to the Skyview Motel in Los Alamos, and parked their buggies. There was an anxious moment or two as the Spencer's woodie began slipping on the hill, with the next car just a few feet behind, but Al put the pedal to the metal and got the woodie safely to the top. The motel afforded us a strange view in Southern California - - an unpopulated expanse of hills and open space.

After a time for story-swapping and tire-kicking, the group lined up once more for a ride into the small town of Guadalupe, where John Powell had made arrangements for us to eat at the Far Western Restaurant, big steaks being the main attraction. Bob Rose surprised everyone by eating the super-colossal 20-oz. steak, and didn't even ask for a doggie bag. The Spencer's daughters, Nicky and Robin, and Bryan Caplan were delighted to learn that video games are even in vogue in a town with one main street.

Following dinner, we drove to a surprise stop at the old Oso Flaco Dairy, and met with owners, Hank Macagni and wife, who showed us through their large collection of handsomely-restored '32 Fords, including a dairy truck. Don Durkee had everyone howling with his gift to Mrs. Macagni, which censorship forbids my describing. The Macagnis presented each car owner with an authentic glass milk bottle from the '40s, as a surprise souvenir.

Back at the motel, a party was held in the Durkee's room, with jokes and drinks flowing freely.

The next day found everyone up surprisingly early for breakfast in the town, and lookie-lookin in the various antique shops, general store, and the famed Union Hotel, before going "on the road again."

For those of you who had to miss the trip, you'll have a chance to redeem yourselves by coming to the Christmas party on December 4th, where a certain Santa Claus will once more entertain us with his sack of jokes and goodies. As the song says, "You'd better watch out . . ."

ANN CAPLAN

THE FOLLOWING IS A LIST OF VINTAGE CARS AND VINTAGE
 PEOPLE WHO MADE THE TOUR
 TO GUADALUPE

***** November 13-14 *****

Corky and Bill Brandenburg.....	33	Roadster
Dorothy and Ed Konecko.....	35	Sedan Convert.
Barbara and Joe D'Addario.....	36	3W Cpe.
Harriett and Bob Rose.....	36	3W Cpe.
Deni and Ed Warnock.....	39	Convert.
Mary and Don Durkee.....	40	Convert.
Frank Williams.....	40	4 Dr.
Ruth and Al Spencer.....	40	Woody
Ann and Larry Caplan.....		Co-Pilots " "
Virginia and John Wolf.....	40	Cpe.
Glen and Norm Booth.....	40	Cpe.
Polly and Chuck Mair.....	41	Cpe.
Ann and John Powell.....	41	Cpe.
MaryAnn and Bob Kennedy.....	41	Convert
Freda and Jim Brittain.....	68	Mustang

Last but not least, our long distance guests all the way from Lake Forst, Illinois and a Ford collector for many years, Marcia and Barrett McGregor driving a '68 Mark III.

Many of the above listed V'8ers brought their sons and daughters also. We are greatly appreciative of your attendance and support and another great outing.

The VALLEY V-8's wish to welcome our newest members.

Whitney Rydbeck 1946 Ford Super DeLuxe 4 Dr.
 9780 Via Zibello Taxi cab
 Burbank, Ca., 91504

Carol Durst 1939 Convert., Ford
 12954 Magnolia
 Sherman Oaks, Ca., 91423

Willy Disselhoft 1937 Cpe.
 322 Crane Bl.
 Los Angeles, Ca., 90065

Marty Leuning 1941 Merc C. Cpe.
 7600 McGroarty 1940 Ford 4 Dr., DLx.
 Tujunga, Ca., 91042

Howard Young
 419 E. Cypress
 Burbank, Ca., 91502 1940 2 Dr. DLx.



BOBS TRANSMISSION SERVICE

DISCOUNT PRICES • 20 YEARS EXPERIENCE
THOUSAND OAKS • CAMARILLO

(805) 482-1868

(805) 492-2132

All★in★1 Printing

THE MOST ECONOMICAL, HASSLE-FREE WAY TO BUY PRINTING IN PASADENA OR
ALMOST ANYWHERE! / 116 W. DEL MAR BLVD. / PASADENA CA 91105 / (213) 795-5554



Typesetting



Quick Printing

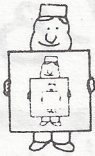

Photostats



Art & Design



Photography

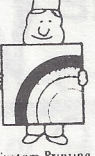

Custom Printing

ASK FOR ALLAN FRANKLIN

MOTORING ACCESSORIES

CUSTOM FIT CAR COVERS

V-8 FORDS

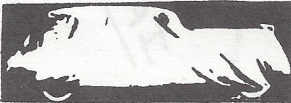

Andy Cohen

200 S. ROBERTSON BLVD.
BEVERLY HILLS, CALIFORNIA 90211

657-4800



7846 ALABAMA AVENUE • CANOGA PARK, CALIFORNIA 91304

(213) 346-6199

CHRISTMAS PARTY

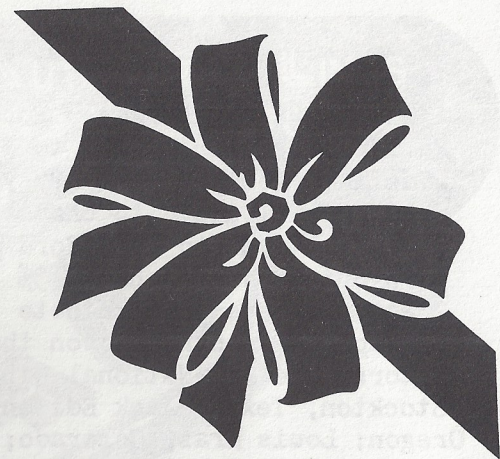

THE VALLEY V-8's

SAT. DEC. 4TH

SADDLE PEAK LODGE
419 COLD CANYON
CALABASAS

IF RESERVATIONS
HAVE NOT

7:00 PM ~ RESTORATION HOUR

8:00 PM ~ DINNER

~ OPEN BAR ~ BUFFET ~ AWARDS

"WITH SPECIAL ATTENTION TO SELE

\$ 25.00 PER COUPLE ~ \$ 12.50 SINGLE

SEND CHECK FOR RESERVATIONS →

BEEN MADE
CALL ED WARNOCK
346-7882

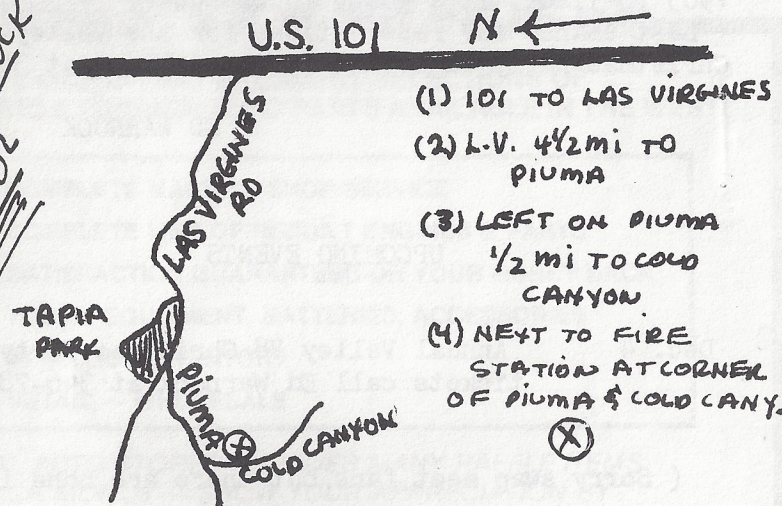

~ LIVE MUSIC ~ DANCING ~

~ RAFFLE ~ SANTA CLAUS ~
"GIVING GIFTS FOR THE LADIES"

★ RESERVATIONS: ED. WARNOCK
A MUST!
BY NOV. 30TH
23223 ARMINTA ST.
CANOGA PK 91304
346-7882

NATIONAL SCENE

Good news ! The Early Ford V8 Club now includes all Ford products from 1932 to 1953. 2109 of the 6647 world wide membership voted 1477 yes, and 632 no, to mandate the National Board to change the National by-laws to include all 1932 to 1953 Ford products. It was a record turn out of votes and 70.3% said yes.

It is interesting to note that only 630 members voted a couple of months ago on the election of National Directors. The new National Directors for 1983 are; Murphy Stockton, Texas; Jack Edison, Indiana; Harold Hanson, Oregon; Louis Mraz, Colorado; Ralph Hubbard, California; Ken Regalia, California.

Make your vacation plans so you can attend the Grand National Meet in Dearborn, Michigan on August 8-13, 1983. The registration form will be in the January-February 1983 V8 Times. It's going to be super.

Last chance for reservations for the Valley V8's Christmas Party on December 4th. Call me at 346-7882.

ED WARNOCK

UPCOMING EVENTS

Dec. 4 Annual Valley V8 Christmas Party. For tickets call Ed Warnock at 346-7882

(Sorry swap meet fans but there are none in Dec.)

CLASSIFIED

For Sale:

1937 Tudor, Hot Rod with V6. \$9000.

1937 V8 Engine, 5 wheels and tires,

rear bumper, transmission, torque tube

and other parts. Dean Taylor 714-980-2386

Your **COMPLETE AUTOMOTIVE LINES**
PARTS STORE



CAL
AUTO STORES

**WE HAVE ONE OF THE BROADEST SELECTIONS OF
DOMESTIC & FOREIGN AUTO PARTS AVAILABLE IN THE WEST!**

- ✓ **COMPLETE MACHINE SHOP SERVICE**
- ✓ **COMPLETE LINE OF REBUILT ENGINES & PARTS**
- ✓ **SATISFACTION GUARANTEED OR YOUR MONEY BACK**
- ✓ **TOOLS, EQUIPMENT, BATTERIES, ACCESSORIES**
- ✓ **\$6 MILLION INVENTORY**
- ✓ **RETAIL — WHOLESALE**

*CAL AUTO STORES SUPPLIES MANY RAFFLE ITEMS
EACH MONTH — SHOW YOUR APPRECIATION BY
BUYING ALL NON-"NO S" ITEMS AT THESE STORES:*

OPEN 7 DAYS & EVENINGS

- North Hollywood, 5740 Lankershim, (213) 984-2573/763-9153
- Sepulveda, 9441 Sepulveda, (213) 892-0791
- Canoga Park, 21407 Vanowen, (213) 347-1015
- Northridge, 8555 Reseda Blvd. (213) 885-8526
- Granada Hills, 17559 Chatsworth, (213) 363-9571
- North Hollywood, 6846 Lankershim Blvd. (213) 765-7731
- Van Nuys, 14939 Oxnard, (213) 786-5071/873-1716
- Panorama City, 14629 Parthenia, (213) 894-9171

WE'VE GOT YOUR PART!

The Valley  *'s*

P.O. BOX 96 - RESEDA, CA 91335

