

86

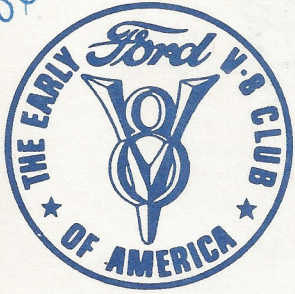

APRIL

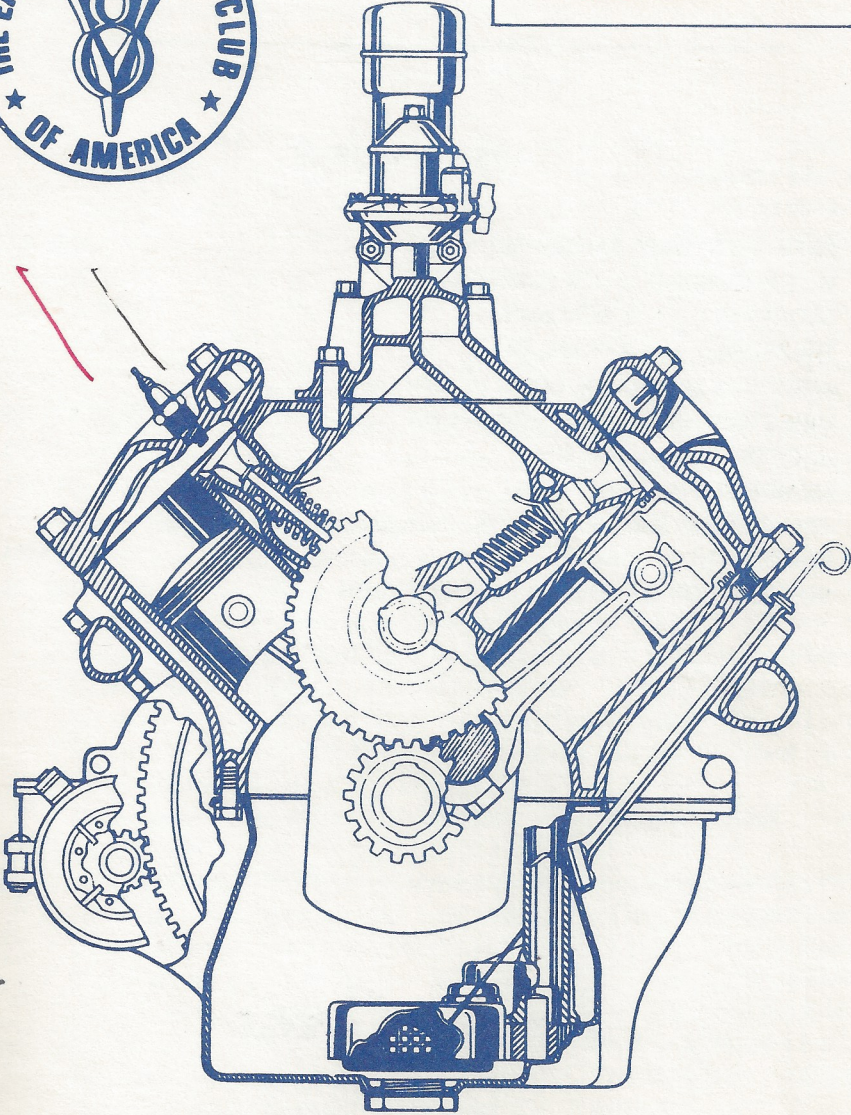

Drive Lines

The Valley 's

1986 OFFICERS

PRESIDENT, DAVE SANBORN.....	986-9174
VICE PRESIDENT, JOHN KEMMERER.....	843-2138
SECRETARY, JULIE BLACKWELL	(805) 499-1021
TREASURER, LARRY CAPLAN.....	363-2849
ACTIVITIES CHAIRMAN, DOUG PETERSON	703-0738
DIRECTOR, HISTORIAN, RUSS SYLVIS.....	(805) 527-4387
ACCESSORIES, ERNIE BAILY	(805) 522-9674
MEMBERSHIP, TERRY SMITH.....	989-3119
FELLOWSHIP, REFRESHMENTS, JACK KELEJIAN.....	996-3744
EDITOR, CHUCK MAIR	785-9413
INFORMATION OFFICER, BOB MCCULLAGH	886-2644

Drive Lines

Published by

SAN FERNANDO VALLEY CHAPTER 40
of the EARLY FORD V8 CLUB of AMERICA

P.O. Box 96
RESEDA, CA. 91335

COVER/ROY JONES

VALLEY V-8's
NEWS AND NOTES
March 1986

LAST MEETING. Several of our past Presidents showed us the leadership qualities that helped build our Regional Group to the powerhouse it is today when each gave us an overview of his term in office. Special thanks to each of you who participated in giving an historical overview: Doug Peterson, 1972-73; Don Durkee, 1974 & 1983; Ed Warnock, 1975; John Busk, 1976; Al Spencer, 1980; Larry Caplan, 1981; Bob Rose, 1982; and Paul Kirk, 1984. Including myself, these participants, organized by John Kemmerer, totaled nine Presidents out of a possible fifteen. The active continuity of leadership over the sixteen years of our Regional Group's existence illustrates our strength. Impressive! Ben DiFatta brought a collage of photographs of club events over the years which also added to the nostalgic interest. John, your Information/Orientation night was a success.

Chuck Mair shared some information on a new process for enhancing reflector surfaces which outlasts silvering. Our Secretary, Julie Blackwell, overviewed our enjoyable tour to the Huntington Library Art Collections and Botanical Gardens. And Pat Berry brought some delicious cookies- thanks Pat.

1986 MEMBERSHIP ROSTER. Terry Smith, our Membership Chairperson, and I thank all of you who got your dues paid in time for inclusion in our 1986 Regional Group Roster. Terry and Paul Kirk are working diligently to get the Roster compiled and

published for distribution.

NEXT MEETING. Sunday April 6 at our regular place, Valley Federal Savings and Loan on the Southwest corner of Nordhoff St. and Reseda Blvd. We will begin at 7pm with visiting in the parking lot. Then we will move indoors about 7:30 for our organized program.

MARCH FEATURE PROGRAM. Jerry Jensen, who was the Chief Judge of Ventura Venture, will present a program on judging Early Ford V8 Club of America cars. This is a great opportunity for all of us to learn more about the judging process from an expert.

CONVERT YOUR TOYS TO CASH! The Crocker Bank representative who was unable to attend our last meeting will explain a loan program using collector cars as collateral. So, if you need cash but don't want to sell your car, come to hear how it can be done.

This April meeting promises to be another winner in the series John Kemmerer has organized.

DRIVE YOUR V-8 REWARD. The parking lot at the last meeting looked like a new Ford showroom from late 1940 with all the great looking 1940 and 1941 models in attendance. I believe three members are still tied for the lead toward the grand prize of best participation for driving a V-8 to meetings. I am not certain because I want to get these notes completed for Chuck Mair before Christine and I leave on Saturday for a week in Hawaii. If I am correct the leaders are Bill Woods, Chuck Mair and Don Dupree. I will get an accurate record when I return. In any case, we all love to see those vintage cars in the parking lot.

FORDS 'N FLOWERS '86

Victoria, British Columbia, Canada is nestled on the southern tip of North America's largest island and is one place you won't want to miss. After enjoying a "mini ocean cruise" on one of the world's largest car ferries through the beautiful scenic Gulf Islands, you will be treated to a little bit of Old England. Double decker buses, horse drawn Tally Ho wagons, changing of the guard and the high tea ritual at the unique Empress Hotel, all add to this old English atmosphere.

FORDS 'N FLOWERS '86 headquarters will be at the world famous Empress Hotel, the dowager Queen of the Canadian Pacific hotel chain and truly a sight to see. Her front yard is the prettiest harbour on the West Coast.

The fact that Victoria caters to tourists all year round, makes this an exciting place to visit. There are over 25 unusual tourist attractions including the world famous Butchart Gardens, Sealand, Craigdarroch Castle and Canada's top ranking Provincial Museum. You will have the opportunity to enjoy chartered salmon fishing, leaving right outside your hotel; a world class Logger's Show and Barbecue and fireworks celebrating Canada's birthday on July 1st. The Ladies Luncheon is planned to be a memorable occasion and the children will have special events to keep them busy and happy. There will be technical seminars at the hotel and the Vintage Car Club and Street Rod Club has scheduled its annual swap meet to coincide with our event. We will leave enough free time so you won't miss any of Victoria's quaint atmosphere or its glamour.

The Concourse setting will surely be one you will not forget. It is to be located on the street in front of the Empress, ringing the Inner Harbour. This promises to be truly a "Concourse d'Elegance."

Early registrants will not only help ensure the success of the meet, but will also be included in the draw for free accommodations. Don't be left out of the excitement and charm of the Empress. Register now for the First International — Western National **FORDS 'N FLOWERS '86**.

There is a Vintage International Auto Show to be held in B.C. Place at Expo '86 (Vancouver, B.C.) July 6 - 10. If you are interested in participating in this event, please contact **John J. Carlson, Vintage International, RR 1, Box 9C, Belcarra, B.C., Canada, V3H 3C8, (604) 931-5948 (evenings) (604) 939-7367 (days)**. Hosted by Vintage Car Club of Canada, Vancouver Chapter.

A Tour to Canada

Jay Harris

In January I announced my plans for an Early V-8 tour to the Western National Meet, to be held in Victoria, British Columbia. For those of you who wish to join us, please take note of the itinerary:

First Day: Thursday, June 26, 1986

Meet at the Shilo Inn Hotel, Pomona, located off of the 57 (Orange) freeway, Temple exit, between the San Bernardino and Pomona freeways. The tour will leave the Shilo Inn at 8:00 AM and proceed east to U.S. 395, then north to the town of Bridgeport for the night.

Motels:	Walker River Lodge	Best Western Ruby Inn
	Box 695	Box 475
	Bridgeport, Ca. 93517	Bridgeport, Ca. 93517
	Phone 619-932-7021	Phone 619-932-7241

Second Day: Friday

Travel from Bridgeport to Klamath Falls, Oregon, via Carson City, Reno, and Susanville.

Motel: Motel 6
5136 So. 6th St.
Klamath Falls, Oregon 97601
Phone 503-884-6273

Third Day: Saturday

Travel to Salem, Oregon, via Crater Lake National Park, Roseburg, and Eugene.

Motel: Motel 6
2250 Mission St. SE
Salem, Oregon, 97302
Phone 503-588-0220

Fourth Day:

Travel up the Oregon coast to the little town of Forks, Washington, via Tillamook and Aberdeen.

Motel: Forks Motel (AAA rated)
Box 510
Forks, Wa. 98331
Phone 206-374-6243

Fifth Day: Travel to Port Angeles-take the ferry to Victoria. Arrival should be before noon.

PLANNED ACTIVITIES FOR FORDS 'N FLOWERS '86

June 29 - July 4, 1986

SUNDAY, JUNE 29	12 noon - 7:00 p.m. 8:00 a.m. - 4:00 p.m.	Early Registration Vintage Car Club Swap Meet and Vancouver Island Street Rod Association
	Free Time	
MONDAY, JUNE 30	8:00 a.m. - 8:00 p.m. 10:00 a.m. - noon 1:00 p.m. - 4:00 p.m. 5:00 p.m. - 9:00 p.m. 5:00 p.m. - 9:00 p.m.	Registration (all day) Safety Inspection Safety Inspection Children's Movies (Prince Albert Room) Ice Breaker (Georgian Lounge)
TUESDAY, JULY 1	7:00 a.m. - 9:00 a.m. - 10:00 a.m. - 3:00 p.m. Noon - 3:00 p.m. 10 p.m.	Judge's Breakfast Concourse Set Up Judging Children's Events All Fun Recreation Park Ladies Luncheon Civic Fireworks
WEDNESDAY, JULY 2	8:00 a.m. - 10:00 p.m. 3:00 p.m. - 6:00 p.m. 6:00 p.m. - 10:00 p.m.	Mini Swap Meet Tour Day: Butchart Gardens, Sealand, Museums (Provincial, Wax, Classic Car) Salmon Fishing, etc. Travel to Sooke World Class Loggers Show and Bar-B-Que; Touring Awards
THURSDAY, JULY 3	6:30 a.m. & 11:00 a.m. 1:30 p.m. - 3:00 p.m. 5:30 p.m. -	Salmon Fishing More tours: Butchart Gardens, Craigdarroch Castle, Government House, Free Time. Technical Seminars in the Georgian Lounge Children's Events All Day, Plus Movies and Dance at UVic Awards Banquet at UVic Travel by V8 or Double Decker Bus
FRIDAY, JULY 4		Breakfast on your own and a leisurely tour back home. Plan to take in some more of the interesting Victoria attractions or plan on attending Expo '86 in Vancouver.

* Recommended route to Victoria by B.C. Ferries from Vancouver — hourly sailings.



FORDS 'N FLOWERS '86

June 29 - July 4, 1986

REGISTRATION FORM

(EARLY REGISTRATION DEADLINE MAY 1, 1986)

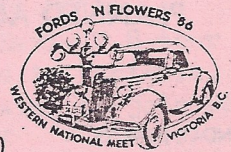

Last Name _____ First _____ Spouse _____

Children's Names and Ages _____

Do you require babysitting services _____

Address _____

City _____ State/Prov. _____ Zip/P.C. _____ Phone _____

Regional Group _____ Make, Model and Year of Car _____

I will enter my car for judging

Show Class: Dearborn _____ Dearborn Medallion _____

Concourse _____ Original _____ Touring _____

I will help with judging Year _____

First Choice Open Closed Year _____

Second Choice Open Closed Year _____

FORDS 'N FLOWERS '86 PRICES: All in U.S. Funds Please

Early Registration Fee (2 adults max.) \$30.00 _____

Late Registration Fee \$45.00 _____

Concourse Boxed Lunches _____ @ \$ 6.00 _____

Banquet _____ @ \$18.00 _____

Bar-B-Que _____ @ \$16.00 _____

Ladies Luncheon _____ @ \$15.00 _____

T-Shirts Womens S M L XL _____ @ \$ 7.00 _____

T-Shirts Mens S M L XL _____ @ \$ 7.00 _____

Necklace _____ @ \$ 5.00 _____

Hat Pins _____ @ \$ 4.00 _____

Gear Shift Knobs _____ @ \$ 8.00 _____

Driving Cap _____ @ \$ 6.00 _____

Salmon Fishing Charters (4 Hrs. — Limit 100) _____ @ \$45.00 _____

TOTAL \$ _____

U.S. FUNDS

Clip and mail to:
Registration Chairman
Ken Clark
4046 Glanford Ave.
Victoria, B.C., Canada V8Z 3Z8
(604) 479-1492

Please make cheques/money orders
payable to:
FORDS 'N FLOWERS '86
(There will be no money refunded after June 15, 1986)

Old Cars Driven By Members

Michele Young	40 Coupe
Bob Blackwell	40 Coupe
Ernie Bailey	48 Plymouth
Larry Caplan	41 Conv.
Chuck Mair	41 Coupe
Bob Rose	41 Conv.
John and Virginia Wolf	40 Coupe
Harold Selsar	36 Coupe
Ralph Froiland	40 Conv.
Bill Velzy	40 Std Coupe
John Wedberg	32 Victoria
Don Dupree	46 Pick-up
Bill Woods	40 Coupe
Pat Berry	50 Ford
Frank Willams	41 Coupe
Jack Kelejian	36 Coupe
Clark Hansen	56 Pick-up

Parts Parts Parts Parts Parts Parts Parts Parts Parts

Harold Selson has 36 Ford parts 818-789-1044

Bruce Blackwell still looking desperatley looking for 36 dash. 805-499-1021

41 Ford rear w/springs for Sale w/brakes
Don Durkee 805-495-5298

IMPORTANT

Don't forget about the parts auction coming up in
may. Please no JUNK!

Glycerine will extend the life of rubber indefinitely.
Get it at the drug store.

A POSITIVE GROUNDED SYSTEM, FORD THEORIZED, WOULD SLOW
OR DIMINISH CORROSION.

Trying to check your brake lights? Try the reflection
in a store front window.

AN OLD SCREEN DOOR SPRING HELPS TO PREVENT KINKS WHEN
BENDING COPPER TUBING. From: Model A Club of America

DESERT WILDFLOWER TOUR - 86

SATURDAY
APRIL 5TH
&
SUNDAY
APRIL 6TH

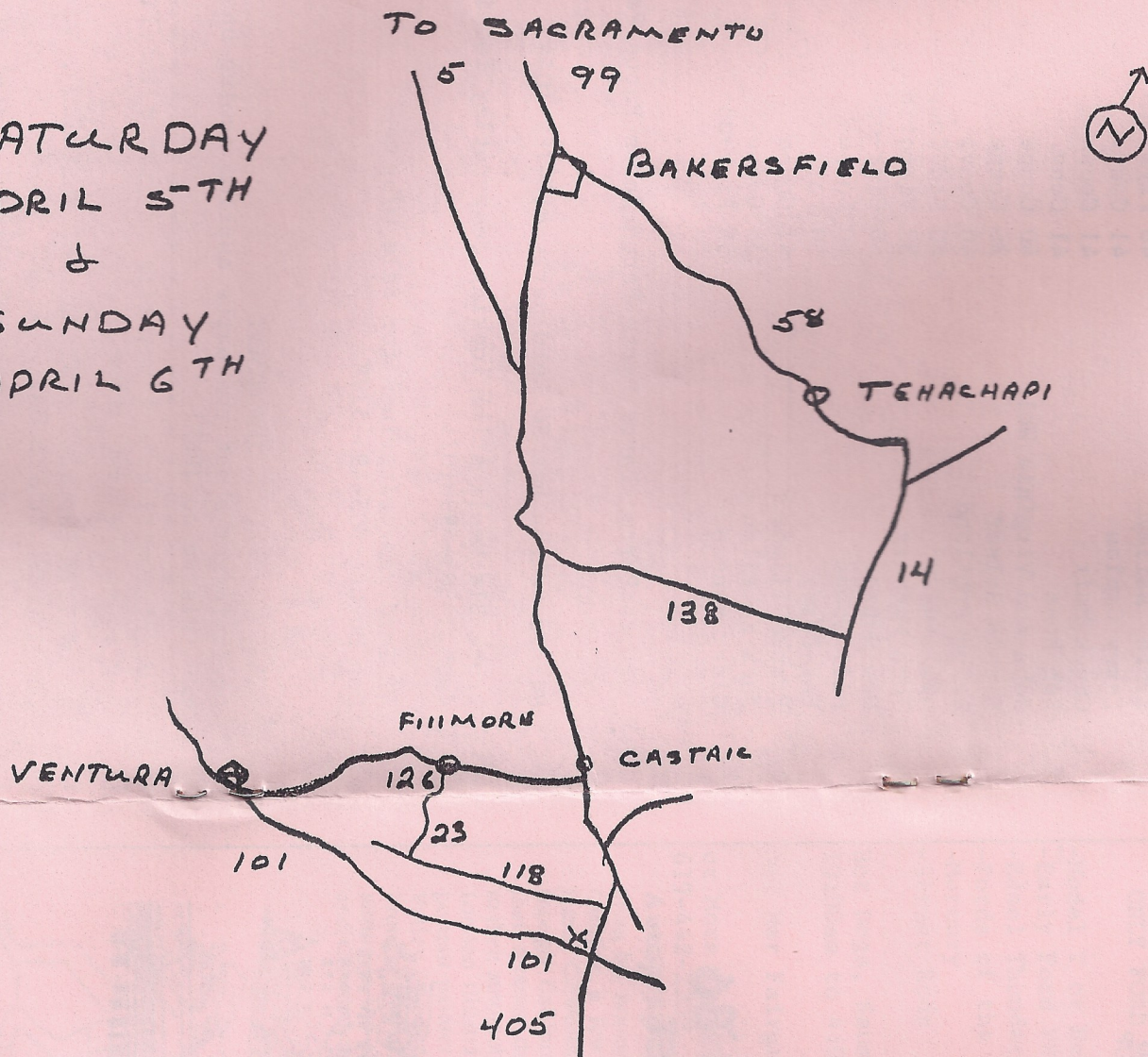

SAN FERNANDO GROUP WILL START FROM BALBOA PARK AT 8:00 AM.

VENTURA & SAN FERNANDO GROUPS WILL MEET IN CASTAIC AT THE CASTAIC RESTAURANT. WE WILL LEAVE AT 10:00 AM.

MAKE MOTEL RESERVATIONS AT MOTEL 6 NORTH
5241 OLIVE, BAKERSFIELD, CA. (805) 392-1028
AS SOON AS POSSIBLE

EARLY FORD V-8 CLUB OF AMERICA
VANCOUVER ISLAND REGIONAL GROUP
PRESENTS

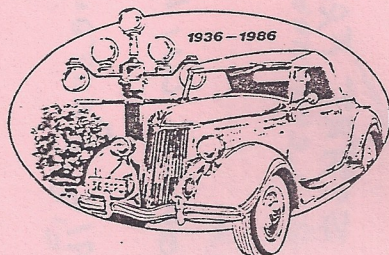

FORDS 'N FLOWERS '86
WESTERN NATIONAL MEET
VICTORIA, B.C.

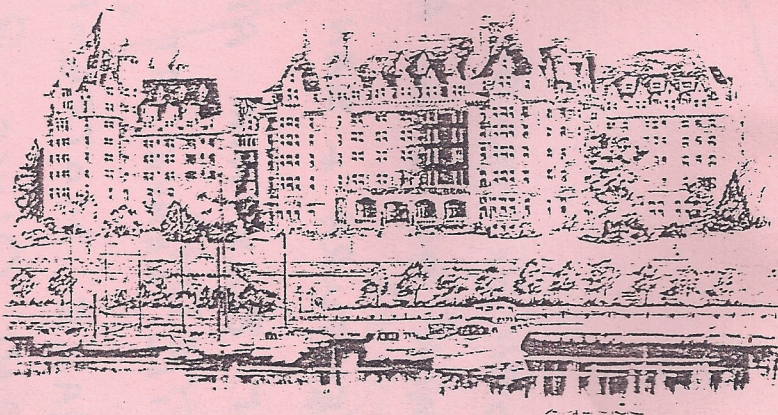

June 29 - July 4

All Ford Picnic...

Sunday April 27, 1986 at the Del Mar race track
Gate opens at 9:00 am No charge to vehicles entering
fairgrounds area. \$5.00 per vehicle entering infield

ONLY FORD MOTOR COMPANY VEHICLES

- Model T or Model A
- Early Ford V8's
- Edsel Thunderbirds or Lincoln
- Fords of the Fifties
- Mercury
- Street Rods

Hot Dogs, Sausage, BBQ, Soft Drinks will be available
10:00am to 4:00pm

Del Mar Fairgrounds. Rules Prohibit Cans and Bottles.

or More Information Please Call Earl Williamson
619-442-2239

Autographs

From his hot-selling poster of a '59 Cadillac a few years ago, Harold James Cleworth discovered that although Californians often jettison their spouses, they are always faithful to their automobiles. So the one-time London illustrator has become the portrait painter to the cars. Silicon Valley tycoon Thomas Perkins brought his 1933 Duesenberg for a sitting in the artist's Venice studio, and Cleworth has painted the chili-

pepper-red Lamborghini of television actor John Schneider. The price—pardon, *commission*—of these portraits starts at \$10,000, and there are cars he won't paint. "A lot of these neo-classics," he says, "make my blood curdle." Cleworth, who drives a turquoise-and-cream '58 Chrysler Imperial, says cars are quite the perfect artist's model. An Edsel, which has "the silliest face I've ever seen," can hold that smile forever.



Ford Owners Agree ~

There's no place
like HOME
for Ford Service

..your Ford dealer knows your Ford best!

WILDFLOWERS IN APRIL. Doug Peterson's tour to Tehachapi and the Antelope Valley California Poppy Reserve on Saturday, April 5th is coming soon so mark your calendars. Doug will be sending out a flyer with the details.

PORTLAND SWAP MEET. Larry Caplan, Jack Miles, Blackie Blackwell and Pat Berry are joining me to go to the Portland swap meet. If anyone else would like to join us, let me know.

ANNUAL PARTS AUCTION. Our annual parts auction will be at our regular meeting on Sunday May 4th. Bill Norton will again be auctioneer. With his inimitable style we are guaranteed to be well entertained. But, to make the auction a success Bill need things to sell. He asked me to pass on his request, "No junk!". So start collectiong your quality contributions now. Remember every dollar raised goes to our club treasury.

FELLOWSHIP and REFRESHMENTS. We are fortunate to have Jack Kelegian taking care of fellowship and refreshment. He greets people with a warm smile and friendly handshake. He also takes care of coffee and snacks so efficiently that his efforts could easily be overlooked. Jack we notice and appreciate the capable job you perform. Your behind the scenes role is important to our team effort. Thanks.

I look forward to seeing all of you at the next meeting.

Dave Sanborn

Secretary Sez. . .

We had a great turn out for March. The room was packed for friends, family and prospective members.

We were delighted to have some of our past presidents come and tell us a little about their years in office and the forming of our club.

Thank You very much for coming

Frank Willams has many cars for sale. If interested he passed out some lists with all the cars make and year. Please Call 805-492-2132

Doug Petersen is doing a great job as activities chairman. Antelope Valley Wild Flower Tour will be in the first part of April this will be a week-end tour.

Enclosed is a flyer on the Western National Meet in Victoria. We encourage you to look into this meet. There has been many articles in the local newspapers about the 1986 Expo. What a great combination, the 86 Expo and a full filled V8 Meet! DON'T Be Left Out!

Many of you were in question about the V'8 jackets many of us wear. Jan-Divers is the creative lady that does all the jackets.

Jan Divers
3925 Monroe St.
Ventura, Ca 93003
805-642-3752

Total Cost Of The Jacket
\$61.14 This Includes
-royal blue zipper front
jacket
-embroiderd patch
-valley v8s on back
above patch
-your name
-shipping

Special thanks to Pat Berry for bringing the refreshments for February.

The pot was finally collected by Al & Ruth Spencer. It had grown to \$45. BIG ONES It could'nt of happened to a nicer guy!

See Ya in April

A. O. O.

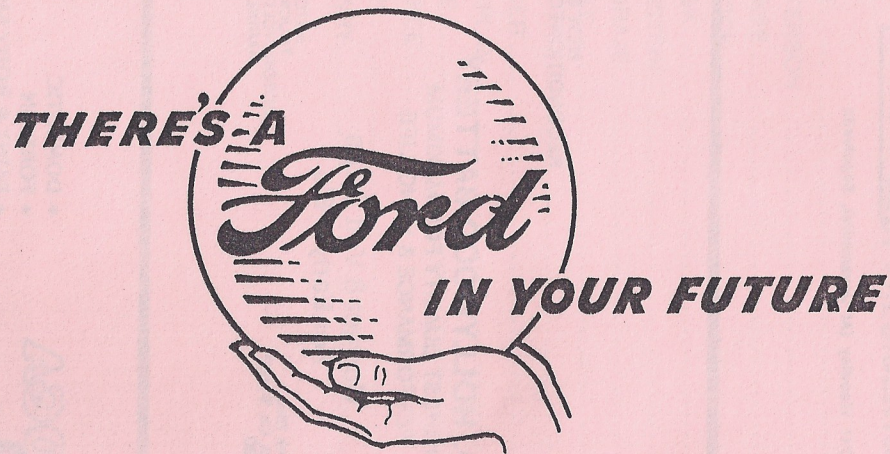

Ford

DON'S Auto Parts

MACHINE SHOP and BALANCING

Monday thru Friday 9 a.m. to 8 p.m.

Saturday 9 to 6 - Sunday 10 to 4

Domestic &
Foreign
Parts & Supplies



894-6441

10241 Woodley (At Devonshire), Sepulveda



NEW &
RECONDITIONED

NO. HOLLYWOOD BATTERY

HIGHEST QUALITY FOR MAXIMUM
PERFORMANCE & LONG LIFE

Correct 6 Volt Sizes
For Early V-8's

10748 Burbank Blvd.
No. Hollywood, Ca. 91601
(818) 766-5530

AUTO
TRUCK
MOTORCYCLE
MARINE

CANOGA AUTO PARTS

Serving You Since 1955

RICHARD MATHIESEN

Manager

340-1536

21422 SHERMAN WAY, CANOGA PARK, CA 91303

- DOMESTIC
- FOREIGN
- PAINT & BODY SHOP
SUPPLIES

PAST PRESIDENTS

JIM ROWE	1971-72
DOUG PETERSON	1972-73
DON DURKEE	1974
ED WARNOCK	1975
JOHN BUSK	1976
CHIP WERSTEIN	1977
STAN MASRAJE	1978
BOB DRAKE	1979
BILL CULP	1979
AL SPENCER	1980
LARRY CAPLAN	1981
BOB ROSE	1982
DON DURKEE	1983
PAUL KIRK	1984
KENT LOWRY	1985

The Valley 's

P.O. BOX 96 - RESEDA, CA 91335

