

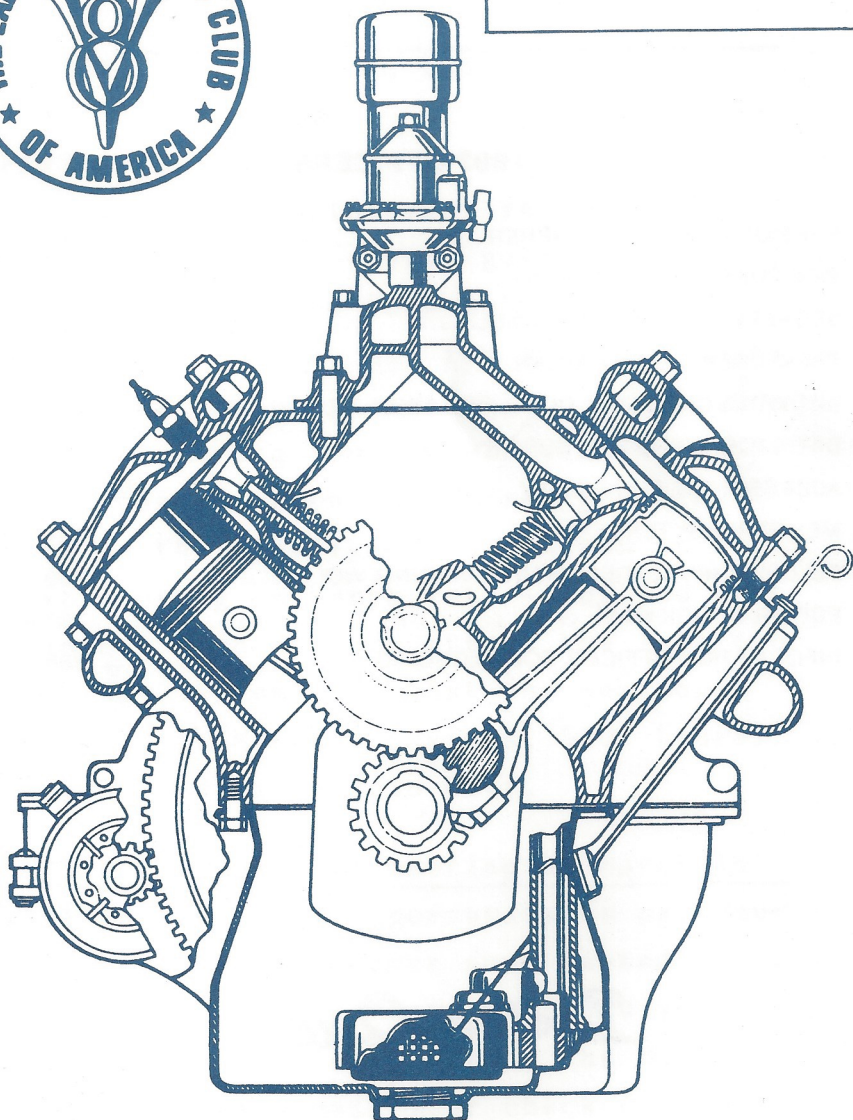

MARCH



# Drive Lines

# The Valley s

---

## 1987 OFFICERS

PRESIDENT, JOHN KEMMERER .....	843-2138
VICE PRESIDENT, PAT BERRY .....	848-5466
SECRETARY, JULIE BLACKWELL .....	(805) 499-1021
TREASURER, LARRY CAPLAN.....	363-2849
ACTIVITIES CHAIRMAN, DOUG PETERSON .....	703-0738
DIRECTOR, HISTORIAN, RUSS SYLVIS .....	(805) 527-4387
ACCESSORIES, ERNIE BAILY .....	(805) 522-9674
MEMBERSHIP, TERRY SMITH.....	989-3119
FELLOWSHIP, REFRESHMENTS, VIRGINIA WOLF .....	789-6201
EDITOR, CHUCK MAIR .....	785-9413
INFORMATION OFFICER, BOB McCULLAGH.....	886-2644

---

## *Drive Lines*

Published by

SAN FERNANDO VALLEY CHAPTER 40  
of the EARLY FORD V8 CLUB of AMERICA

P.O. Box 96  
RESEDA, CA. 91335

COVER/ROY JONES

Valley V-8"s

Nuts & Bolts

March 1987

FANTASTIC, that's the description of Jerry Jensen's talk on interior restorations at the last meeting. Jerry gave us an indepth description of the "how to" for seats, panels, head liners and top pads. - Thanks for an excellent presentation Jerry. Don't forget to bring your regulators and coils to be tested, when Don Dupree gives his talk on the Ford ignition systems at our next meeting on March 1st. - For you that have not been able to attend the last two meetings, a reminder that the meetings are held at Mercury Savings, 5201 Laurel Canyon Blvd. in Studio City.

DUES DUE - Our next meeting on March 1st will be your last opportunity to pay your 1987 dues and have your name listed in our '87 roster. If you have not paid your dues and will be unable to attend the March meeting, please mail your check for \$12 to the P.O. Box or to Terry Smith right away. - This will be the only notice you receive before the roster goes to print.

Elsewhere in this newsletter you will find a copy of a letter we received from Fred Herrlein, the 1986 National Membership Chairman (rumor has it that Fred is also our newly elected National V-8 Club president). As mentioned in the letter we have received a copy of the V-8 album published by the National a little over a year ago. The album will be turned over to Dave Sanborn to be Auctioned off at our annual auction in May. - Start collecting your extra parts now for the auction - This is our major fund raiser of the year and we really need all of your help with donations.

Also in this copy of the Drive Lines is a note from Jay Harris who is organizing a tour to the Western National Meet in Bend Oregon. I spoke to Jay the other night and he said he would be glad to have any Valley V-8ers join him on the tour - even Blacky and Durkee are invited but the club will have to post a bond. If you're interested in touring with Jay, call him at (714) 586-4150 before 8:00 in the evening. Speaking of Bend, its not too early to get your room reservations for the meet. Mail the card included with the Jan. - Feb. issue of the V-8 Times, but put it in an envelope when you mail it. I filled out my name and address on the card as instructed and the Post Office mailed

it to my address.

Another Oregon tour is Dave Sanborn's Second annual tour to the Portland Swap meet for the weekend of April 10th. However, tour participants will be flying on this one with overnight accommodations courtesy of the Sanborn Hilton. If you're interested, give Dave a call.

As mentioned at the January meeting, thanks to Fred Chaparro of the Automotive Book Stop on Magnolia in Burbank, I now have an almost complete set of the V-8 Times. It's amazing what you can find in your own neighborhood if you take the time to look and ask. Club members are welcome to borrow any of the issues for reference. Volume one, two and three are incomplete and I still need volume six, number one. - The earlier issues make interesting reading. In particular I discovered that the National Club had only forty members and a treasury of \$150 just twenty five years ago. The National currently has in excess of 7,000 members. When you get a chance stop by to see Fred. He just might have that manual or literature you have been looking for.

Thanks to Garry Blackwell for coordinating our tours and events. - Contact Garry for detail on any of the events.

The Association of California Car Clubs (ACCC) has asked us to send a representative to their Automotive Hobbyist Conference to be held in Sacramento on May 3 & 4. - The ACCC is an organization dedicated to protecting the car collecting and restoration hobby. Our club has been a member of the ACCC for several years and their influence was demonstrated a couple of years ago when The City of Los Angeles attempted to pass an ordinance restricting the number of automobiles you could have on your property. They are currently lobbying in the areas of mandatory inspections, higher taxes, tougher DMV regulations restrictions on pleasure driving and retrofit of safety devices, where these areas of legislation affect the car collecting hobbyist.

The purpose of the Sacramento conference will be to enhance the ACCC's image in Sacramento, discuss automotive problems and outline goals for the ACCC's future. Please let me know, prior to our next meeting, if you would be interested in representing our club at the conference.

Valley V-8's  
1987 Activity Calendar

First Sunday - Valley V-8's Monthly Meeting  
Of each month 7:00 p.m. Mercury Savings  
5201 Laurel Canyon Blvd.  
Studio City, CA

---

- April 4 & 5 - Doug Peterson's Desert Flower  
Tour
- April 10-12 - Dave Sanborn's Portland Swap  
Meet tour
- May - Don Durkee's Solvang tour
- May 3 - Annual Auction  
Bob Rose's Tequila Willies tour  
(Date to be announced, if we can talk Bob  
into it)
- June - '40 Ford Picnic
- July - Pat Berry's Chili Cookout at  
Wheeler Springs
- August 4-8 - Western National Meet - Bend,  
Oregon
- September - John & Bonnie Busk's Annual  
Pizza Night
- October - All Ford Picnic  
- Dave Sanborn's Quad Clubs' Breakfast
- November 14 - Merle Norman - San Sylmar Tour
- December 4 - Installation Dinner and Christmas  
party - Al Spencer

Thanks to Gerry Blackwell for coordinating  
our tours and events. - Contact Gerry for  
details on any of the events.

Bits and Pieces:

- Kudos, to Paul Kirk for sending the refreshments to the last meeting, even though he was unable to attend. Thanks to Larry Caplan for bringing the goodies from Paul.
- Jeers, to ~~Tom~~ <sup>CHUCK MAIR</sup> for not including our sponsors ads in our last newsletter. - Please don't forget to support our sponsors, including Mercury Savings who provides our meeting place each month.
- Tom Welch's '40 coupe and Curtis V-8 have taken a back seat while he works on his new Offen-hauser powered racer.
- Anthony Di Meo missed out on a sawbuck when his name was drawn at the last meeting. There will be \$15 in the next drawing.
- It's great to hear that Ed Warnock is back in the cockpit flying 727s.
- Pat Berry still has raffle tickets for the Bend Western National.

See you at our meeting in March.

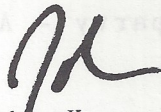

John Kemmerer





*The Early Ford*



CLUB OF AMERICA  
P. O. Box 2122  
San Leandro, California  
94577

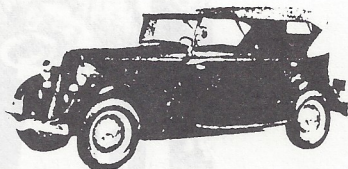

January 25, 1987

San Fernando Valley Regional Group  
P. O. Box 96  
Reseda, California 91335

Regarding: 1986 Membership Contest

Congratulations! With your efforts we have had a very successful year, and a V-8 album will be sent to you in two or three weeks, 4th class mail.

The contest ended on December 31st. We gained 1584 new members in 1986 and set a new record.

If you do not receive the V-8 album please call or write me.

Best regards,

*Fred Herrlein*

Fred Herrlein  
1986 National Membership Chairman

# THE FUN CAR CLUB

## INTRODUCTION:

The Early Ford V-8 Club of America is a non-profit corporation of California and a National Historic Society dedicated to restoration and preservation of Ford Motor Company vehicles 1932 through 1953. Although the basic interest of this club is the Early Ford V-8, ownership of these cars is not a prerequisite for membership. Your interest in the Early Ford V-8 is all we require. Consider this an invitation to join us in this fun-filled hobby.

## REGIONAL GROUPS:

Some one hundred Regional Groups are scattered around the country. There may be a Group near you. The addresses of Regional Groups are included in the annual Membership Roster. For details on how to form a Regional Group write: Regional Group Chairman, PO Box 2122, San Leandro, CA 94577.

## ACTIVITIES:

- TOURS
- SWAP MEETS
- PARTIES-PICNICS
- CONCOURS
- NATIONAL MEETS

Treat the entire family to the full scope of old car ownership. Unlike many vintage automobiles the Early Ford V-8 is as much at home on today's highways as it was on the roads of yesteryear. Why sit back and "Watch the Early Fords Go By?" Join the Early Ford V-8 Club of America and discover how much fun a hobby can be.



### APPLICATION FOR MEMBERSHIP

SAN FERNANDO VALLEY V-8'S REGIONAL GROUP  
OF

THE EARLY FORD V-8 CLUB OF AMERICA

\*You must belong to  
National V-8 Club

PLEASE PRINT

Date \_\_\_\_\_

Name \_\_\_\_\_ Spouse \_\_\_\_\_

Address \_\_\_\_\_  
STREET CITY STATE ZIP

Telephone No. ( ) \_\_\_\_\_ Occupation \_\_\_\_\_  
AREA

Cars Owned \_\_\_\_\_  
LIMIT 3

Annual Regional Group Dues \$ 12.00 Please Pay Regional Group Direct. Do Not Send in to National

## THE EARLY FORD V-8 CLUB OF AMERICA APPLICATION FOR MEMBERSHIP

PLEASE PRINT

Name \_\_\_\_\_ Spouse \_\_\_\_\_

Address \_\_\_\_\_  
STREET CITY STATE ZIP

Telephone No. ( ) \_\_\_\_\_ Occupation \_\_\_\_\_  
AREA

Cars Owned:

Referred By  
Regional Group

Year	Model	Body Style	Engine Type*
------	-------	------------	--------------

THE EARLY FORD  
V-8 CLUB OF AMERICA  
PO BOX 2122  
SAN LEANDRO, CA 94577



(Enclose check/money order for annual dues \$ \_\_\_\_\_ payable in U.S. funds.)



## TOUR TO BEND

by Jay Harris

Believe it or not the Western National Meet in Bend, Oregon is only six months away!!! As in previous years I am putting together a tour to the meet.....in fact, the route, itinerary, and some of the sightseeing has already been set. The itinerary is as follows.....

### First Day - Thursday, July 30:

Drive to King City via Highway 101, with stops in Newberry Park, Santa Maria, and San Luis Obispo.

### Second Day - Friday, July 31:

Drive to scenic Carmel....spend the day seeing sights such as 17 Mile Drive, Cannery Row in Monterey, etc. We'll spend the night in a quaint motel in Carmel.

### Third Day - Saturday, Aug. 1:

Drive north to San Francisco, with stops in San Jose, Lombard St., then on to San Rafael for a picnic lunch in the park. and east thru the wine country of the Napa Valley, and finally north to Red Bluff for the night.

### Fourth Day - Sunday, Aug. 2:

Today we will sightsee in beautiful Lassen Nat'l Park, ending the day in Yreka.

### Fifth Day - Monday, Aug 3:

Today we will drive to Grants Pass, Oregon, for a stop at Bob Drake's, then on to Eugene for the night.

### Sixth Day - Tuesday, Aug. 4:

The meet begins today, and we will take scenic routes 126 and 242 into Bend, arriving by noon.

Now is the time to plan your '87 vacation! Join us!!!!!!!

chatterbox(chat'er.boks),one who or that which chatters. an incessant talker. to utter a rapid series of short sounds such as giggling. HA sound like anyone you know?

CHATTERING AWAY,,,,,...#%\$¢((¢\*&))(@¢%"¼:?.?,,°,°+\_ )@#

Welcome visitors Caesy and Julie Tauvaga, George Willaims, Bill Ralston and Bob Mcroy

Dave Sanborn is organizing the Portland swap meet tour . According to the swapiers from last year you won't want to miss this tour and swap meet. Alaska airlines from Burbank for approx \$I98.00

Dues are due, da due due due...

Raffle tickets displayed in this issue can be purchased from Mr. Pat Berry selling them out of his 50 ford trunk. Thsnks Pat for your efforts and all the lovely pictures you try to take.

Anthony DiMeo not present to collect \$I0.00 now up to \$I5.00.

Jerry Jensen gave the program on all his techniques of restoration and upholstery , THANKS JERRY

ATTENTION ATTENTION ATTENTION ATTENTION ATTENTION  
Jack Miles, expert salesperson and car restorer has a new car 1940 Ford Convertible, Rumor has it he will be selling this car. I think he's Saving all his convertible energy for the Blackwell's 1940 Ford convertible which rumor also has it is his daughters 23rd birthday present in august.GOOD MAN THAT BLACKY

Congradulations to the Durkees on their recent anniversary. What a cute couple.

Well our first tour of the year was a HIT HIT HIT we TORA TORA TORAED to the Tillman reclamation plant and Japanese Gardens Among the tourees were

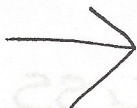



Jay and Barbara Fortman in their 56 Ford Truck, Dave Sanborn and Christine Varney in their 35 Conv Sedan, John and Virginia Wolf in Virginia's Blue Coupe, Larry and Ann Caplan in their 40 Standard Tudor, Pat Berry in his 50 Ford, The Peterson Team of Doug and Doug in their 34 Truck, The Blackwells 3 in their Coupe and 40 Woodie. Also joined by the Sencers Al and Ruth and Last but not least those crazy Veeleys finally showed up for a tour, you know we always make the tours and we live in Thousand Oaks, just because you guys live in Oregon you show up more often. Great to see everyone out there and thank you for your support.

As we marched silently in a single file line through the prison like plant with warden Normie Terry as our guide. One sound and off with your head. You look where I tell you and nowhere else LEFT LEFT LEFT RIGHT LEFT, we marched not a hair out of place into the Japanese gardens. Normie was very knowledgeable about the Japanese culture decor and tradition. We were such bad little V-8 ers we made Normie late for his next tour. We gabbed and didn't march fast enough at least one girl didn't can't seem to recall her name. Such Bad little V-8ers. Well Normie we'll make this one an annual event and we'll call ahead to have you as our guide.

After we were paroled we all toured to the 94th Aerosquadron for lunch where I saw the most handsome mushroom cheddar burger i've ever seen!!!

Special Thanks to Chuck Mair, My GREAT EDITOR FOR BEING SO PATIENT WITH ME.

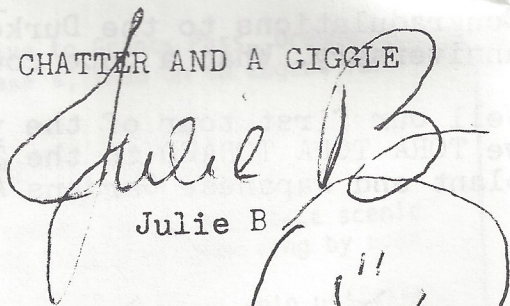
CHATTER CHATTER AND A GIGGLE  
OR TWO

  
Julie B  

KISS

OLD CARS DRIVEN BY MEMBERS

PAUL MONTROY	40 FORD COUPE
PAT BERRY	50 4-DOOR
JAY FORTMAN	4i FORD
HOADY HOLST	4i FORDC FORD
C. GEORGE WILLIAMS	46 FORD TUDOR
BARBARA FORTMAN	4i FORD
BILL CULP	29 ROADSTER
JOHN WOLF	40 COUPE
LARRY CAPLAN	40 TUDOR
RUSS SYLVIS	37 FORD
JULIE AND CASEY TAUVAGN	40 FORD COUPE
MILT CAROLE AND TOM RALSTON	57 FORD
BOB ROSE	57 MERC
CHUCK MAIR	4i FORD SPEC COUPE
BOB MCROY	56 Chev
HAROLD SELSON	36 FORD
TED HERSCH	36 FORD
JOHN AND VIRGINIA WOLF	40 TUDOR
JOHN KEMMERER	40 TUDOR

# DESERT WILDFLOWER TOUR - 1987

SATURDAY  
APRIL 4TH  
‡  
SUNDAY  
APRIL 5TH

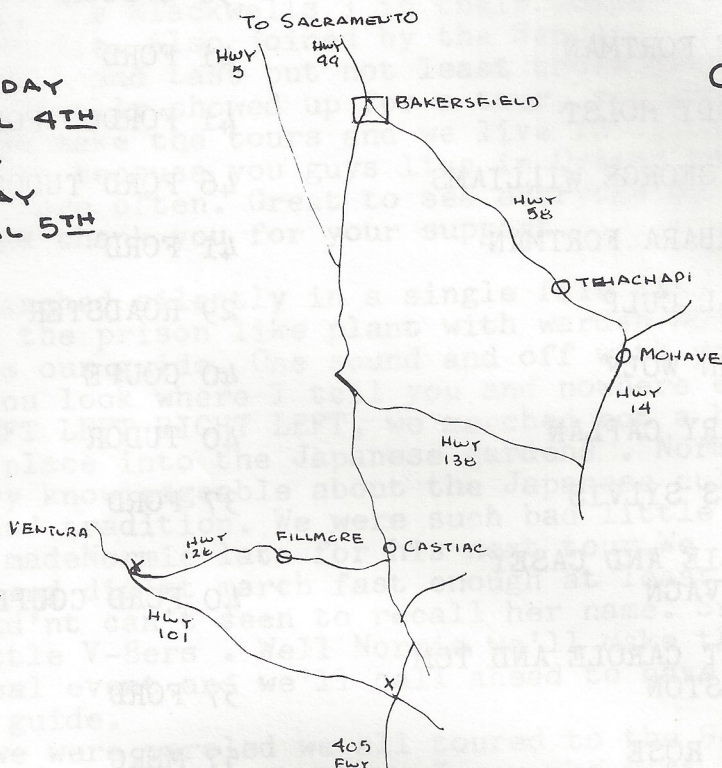

SAN FERNANDO GROUP WILL START FROM BALBOA PARK AT 8:00 A.M.

VENTURA ‡ SAN FERNANDO GROUPS WILL MEET IN CASTAIC AT THE CASTAIC RESTAURANT. WE WILL LEAVE AT 10:00 A.M.

MAKE MOTEL RESERVATIONS AT MOTEL 6 NORTH 5241 OLIVE, BAKERSVILLE, CA. (805) 392-9700 AS SOON AS POSSIBLE.

NOTE: A SIDE TRIP MIGHT INCLUDE A VISIT TO SEE "VOYAGER" - ON DISPLAY AT MOHAVE AIRPORT.

FOR SALE:

49 and 50 FI FORD PICKUPS, EXTRA HOOD &  
TWO DOORS NO MOTORS \$600.00

53 FORD PANEL TRUCK ONE OWNER NEW  
REBUILT CADILLAC ENGINE NEVER BEEN  
RUN HYDRAMATIC PERFECT BODY  
PINK SLIP \$1000.00

CALL J. FORTMAN 818-345-8594

(213) 980-9002



REGIONAL OFFICE  
MERCURY SAVINGS

5201 Laurel Canyon Blvd., No. Hollywood, CA 91607-2709  ® 11

WHO IS THIS YOUNG MAN IN THE PHOTO BELOW?  
BE SURE TO READ NEXT MONTHS DRIVE LINES!

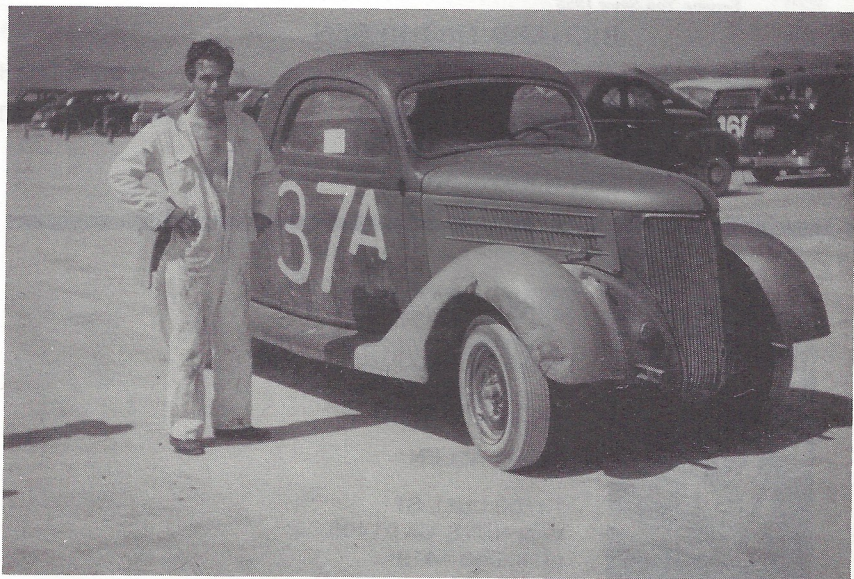



# DON'S Auto Parts

MACHINE SHOP and BALANCING

Monday thru Friday 9 a.m. to 8 p.m.  
Saturday 9 to 6 - Sunday 10 to 4

Domestic &  
Foreign  
Parts & Supplies



**894-6441**

10241 Woodley (At Devonshire), Sepulveda



NEW &  
RECONDITIONED

**NO. HOLLYWOOD BATTERY**  
HIGHEST QUALITY FOR MAXIMUM  
PERFORMANCE & LONG LIFE

Correct 6 Volt Sizes  
For Early V-8's

10748 Burbank Blvd.  
No. Hollywood, Ca. 91601  
(818) 766-5530

AUTO  
TRUCK  
MOTORCYCLE  
MARINE

**CANOGA  
AUTO  
PARTS**

*Serving You Since 1955*

- DOMESTIC
- FOREIGN
- PAINT & BODY SHOP  
SUPPLIES

**RICHARD MATHIESEN**  
Manager

**340-1536**

21422 SHERMAN WAY, CANOGA PARK, CA 91303

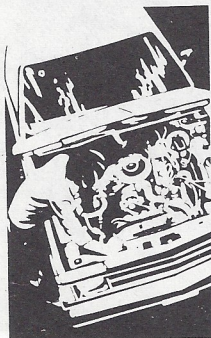

**PRO-CARE  
AUTOMOTIVE  
SERVICE**

JERRY ALLEN

14700 LULL ST.  
VAN NUYS, CA 91405  
(818) 908-1413

PROFESSIONAL REPAIRS & PREVENTATIVE MAINTENANCE, ON ALL  
MAKES OF CARS & TRUCKS

## PAST PRESIDENT

JIM ROWE.....	1971-72
DOUG PETERSON.....	1972-73
DON DURKEE.....	1974
ED WARNOCK.....	1975
JOHN BUSK.....	1976
CHIP WERSTEIN.....	1977
STAN MASRAJE.....	1978
BOB DRAKE.....	1979
BILL CULP.....	1979
AL SPENCER.....	1980
LARRY CAPLAN.....	1981
BOB ROSE.....	1982
DON DURKEE.....	1983
PAUL KIRK.....	1984
KENT LOWRY.....	1985
DAVE SANBORN.....	1986

**The Valley**  **'s**

**P.O. BOX 96 - RESEDA, CA 91335**

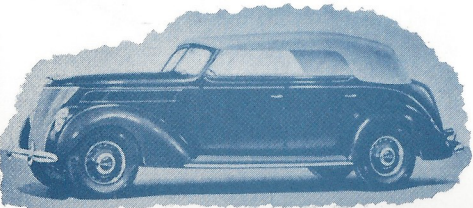
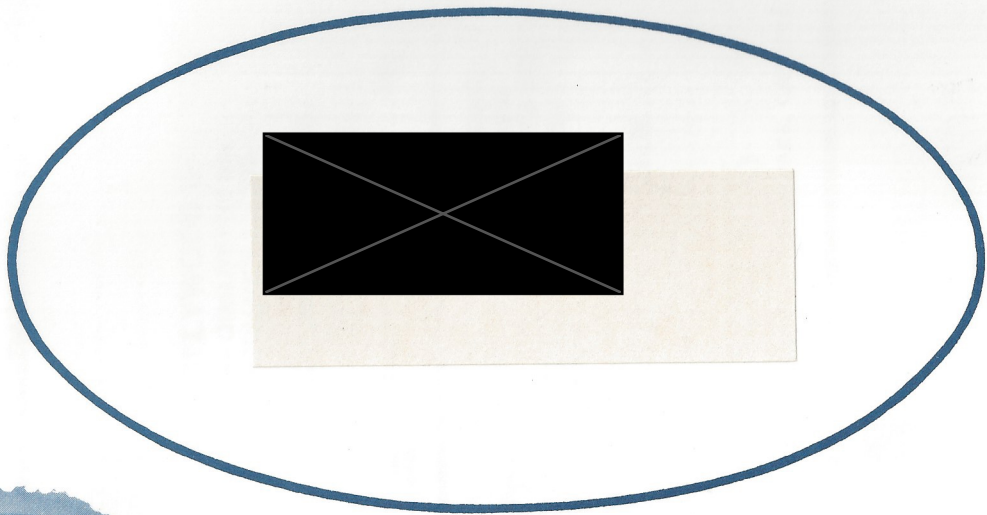

**50th Anniversary**