

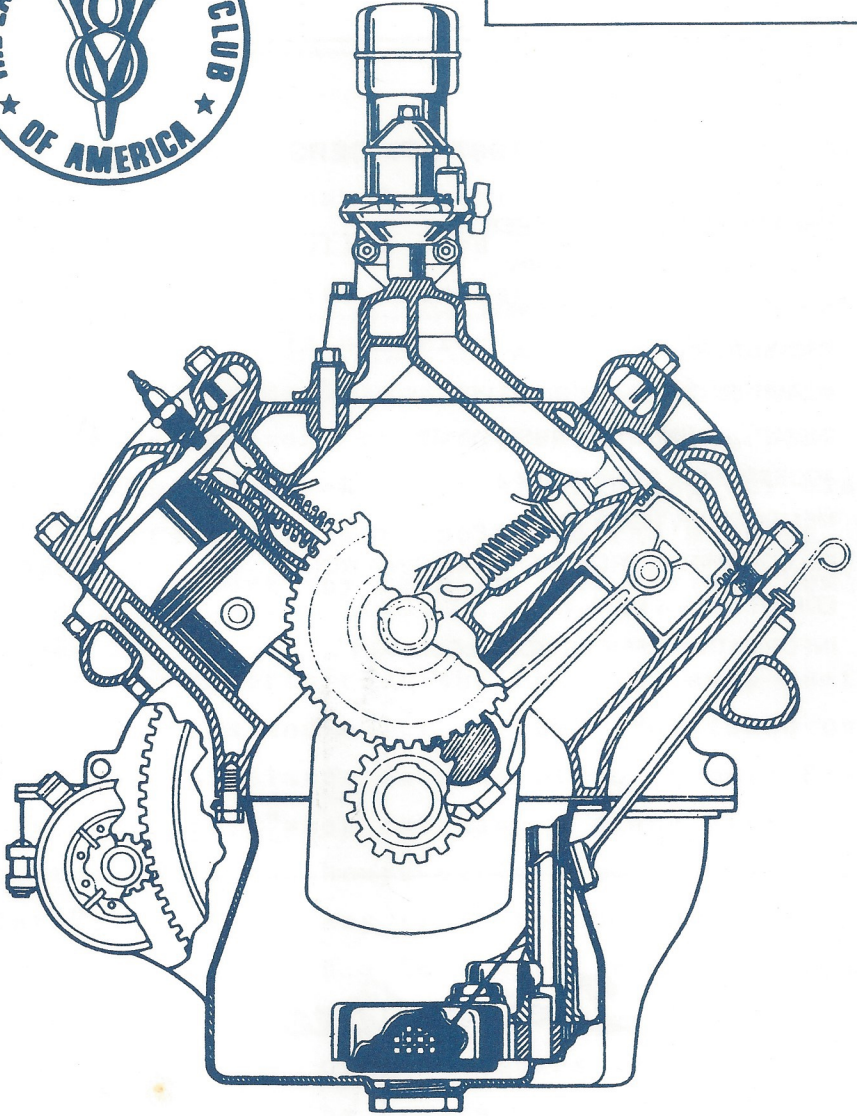

MAY



Drive Lines

The Valley 's

1987 OFFICERS

PRESIDENT, JOHN KEMMERER	843-2138
VICE PRESIDENT, PAT BERRY	848-5466
SECRETARY, JULIE BLACKWELL.....	(805) 499-1021
TREASURER, LARRY CAPLAN.....	363-2849
ACTIVITIES CHAIRMAN, DOUG PETERSON	703-0738
DIRECTOR, HISTORIAN, RUSS SYLVIS	(805) 527-4387
ACCESSORIES, ERNIE BAILY	(805) 522-9674
MEMBERSHIP, TERRY SMITH.....	989-3119
FELLOWSHIP, REFRESHMENTS, VIRGINIA WOLF	789-6201
EDITOR, CHUCK MAIR	785-9413
INFORMATION OFFICER, BOB McCULLAGH.....	886-2644

Drive Lines

Published by

SAN FERNANDO VALLEY CHAPTER 40
of the EARLY FORD V8 CLUB of AMERICA

P.O. Box 96
RESEDA, CA. 91335

COVER/ROY JONES

Valley V-8s

May 1987

One of the club's most popular events is coming up in May, our annual auction. Once again, Bill Norton of Valley Ford Parts will serve as auctioneer, with Dave Sanborn coordinating the evening. In addition to being a popular night for our members, it is the club's major fund raising event of the year - so let's all make this a Super Sunday, by bringing our old auto parts and paraphernalia to the meeting. And if you have any rich friends, bring them along too.

Pat Berry reports that the Portland swap meet was a success and a lot of fun. Pat found out that some airplanes do take off on time. His new motto is, "when catching a plane, its better to be two hours early than two minutes late". Is there any truth to the story that Larry Caplan found a Columbian, that he plans to donate to the club's auction?— What a guy. While many of our members were at Portland, I had the opporunity to visit a swap meet in Watchung, New Jeresy. What made this meet interesting was that it was the first meet of the year for the enthusiasts

back there and most of the vendors and participants were going crazy, after hibernating all winter. We are truly fortunate to be living in southern California when it comes to swapping.

Terry Smith and Paul Kirk have been hard at work putting the information together and computerizing our annual roster. It should be mailed any day now. If your name is not in the roster it means that our records indicate you have not paid your '87 dues. If you don't see your name, or you don't receive the roster by the middle of May, call Terry Smith.

- Was that really Bob Rose, hiding behind those sunglasses, in the Fabulous Fifties booth at Knotts Berry Farms?
- It was good to see Ralph Hubbard Shel Harriman (sans beard) and Tom Welch at the last meeting - Let's make it two in a row guys.
- Paul Montroy missed \$20 in the name tag drawing which means the pot will be worth \$25 at the June meeting.
- Welcome to new members Jim and Barbara Kigar
- Thanks to Mary Durkee for remembering and baking the goodies for our last meeting.

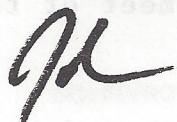
A handwritten signature in dark ink, appearing to be the initials 'JK' or similar, located at the bottom right of the page.

A YEAR OF DECISION.....1972

Valley V8's History Continued by Ed Warnock

The Club had an enthusiastic start, a slate of officers that had agreed to serve through 1972 and had a charter membership of 23 at the end of 1971.

President Jim Rowe got a new job that conflicted with the meeting night and others seemed to lose interest. Doug Peterson and Bob Wilson spark-plugged the effort to keep the club going.

The following excerpts from the June newsletter and a ballot mailed late in June pretty well tell the story of the few who were determined to keep the Valley V8's going.

The first annual Christmas Party was held at the Fog Cutter in Hollywood and the year ended with 23 members and \$45.68 in the bank.

PRESIDENT.....JIM ROWE	DIRECTOR.....PAUL MESKE
VICE PRESIDENT...DICK BERRY	EDITOR.....OPEN
SECRETARY.....BOB WILSON	HISTORIAN.....DOUG PETERSON
TREASURER.....DICK BERRY	ACTIVITIES.....ED HARDIN

CALENDAR OF EVENTS

.

- June 18th - 8th Annual L.A. Roadsters Swap Meet & Roadster Show. Great Western Exhibit Center Santa Ana Freeway at Atlantic Blvd.
- June 18th - Regular Meeting. Valley Federal Savings and Loan, Northridge

August 4,5,6.- Early Ford V-8 Club of America Western Regional Meet. Santa Rosa at El Rancho Tropicana Hotel.

EDITORIAL - "IS THERE A FORD IN YOUR FUTURE?" An Early Ford V-8 to be exact? Is there a club for all those who enjoy, love, are entranced, to put it bluntly, "hooked" on one or more Early Ford V-8's? Well, the answer, hopefully, is a resounding YES to all these questions. But it has been difficult to tell whether the answer was yes or no because of the lack of enthusiasm and attendance at our meetings and the few tours we have tried to put together. Perhaps you say to yourself, "But I'm new. Maybe later, but not until I get more experience. I wouldn't know what to do as an officer, or on a tour or to be a chairman, or to give a talk about restoration tips. Well men, our club is now about 10 months old. Those of you that are fathers (and that is most) how much "experience" did your son or daughter have at 10 months? How much help did you give to help that baby human grow and learn? Our club is much like that. We can look and learn from sister clubs that are older. We can ask for their help to get started, but unless we really care and really try to make it on our own, it's no go! So maybe we'll make mistakes, but we all learn from mistakes, individually and collectively. So why don't we try a fresh start.....all together!?

We have planned no special program for the June 18th meeting for a purpose. That purpose is to have a vote on the future of Chapter 40, The Valley V-8's. If you want the club to continue, want to contribute in some way, no matter how small or large, make a real effort to be there. We know some of our members have had real unavoidable problems making attendance and participation impossible. This happens. However, there must be some that want the club to go on. In any case let's make our wishes known. Be there, June 18th. The meeting will NOT BE LENGTHY, but VERY IMPORTANT!

FUTURE ACTIVITIES:

Depending on the outcome of our meeting we will decide on whether or not to accept an invitation from the Southern California Chapter to join them on two tours. One will be to the Santa Paula Airport where many antique airplanes are hangered and on display. It should be a very interesting tour. Another is a beach party to be held near Ventura. More on these events.....if you want them.....in future issues. Remember.....it's up to you! What will it be?

Hello V-8'ers!

In spite of, or maybe we should say "In addition to", Fathers Day and the L.A. Roadster Show, there was an encouraging turnout at the monthly meeting so vital to our clubs' continuance. Nine members were in attendance and with renewed enthusiasm and looking forward to a new beginning, a ballot of new officers were nominated to serve for the remainder of 1972. All of you, each member, is invited, and urged, to vote for the officers of your choice listed below. Further, a space has been provided for write-in votes, so any name not mentioned which you would like to see in office, including your own, may be written in. There are cases where the same name will appear for two offices. Due to the nature of the office involved it was felt there would be no conflict and the men concerned have agreed to accept either, or both, offices. If you wish, then, to vote for one man for two offices, there will be no problem. Time is of the essence, so we ask that you vote NOW, before you forget or get busy and neglect to get your ballot in promptly. Ballots must be received at our club address, 18909 Malden, Northridge, not later than Saturday, July 1st. The results will be in the next bulletin. Even if you couldn't be at the nominating meeting, right now is your chance to participate in electing a team of officers who, with each members' help can get our club moving again. So, VOTE. . . RIGHT NOW. . . . and mail in your ballot as soon as possible so your voice will help results in your choice

***** TEAR HERE *****

PRESIDENT. . . DOUG PETERSON	<input checked="" type="checkbox"/>	DIRECTOR . . . GORDON CHAMBERLIN	<input checked="" type="checkbox"/>
BOB WILSON	_____	EDITOR. . . . BOB WILSON . . .	<input checked="" type="checkbox"/>
VICE-PRESIDENT. . . ED WARNOCK	<input checked="" type="checkbox"/>	HISTORIAN . . . HAROLD SELSON	<input checked="" type="checkbox"/>
SECRETARY . . . LARRY STOCKER	<input checked="" type="checkbox"/>	ACTIVITIES CHAIRMAN. . . ED HARDIN	<input checked="" type="checkbox"/>
TREASURER . . . STEVE LEACH	<input checked="" type="checkbox"/>	DOUG PETERSON	_____

Pegasus Entertainment Talent Agency, Inc.
Creative Talent Consultants

David Dadon
President

Piazza Del Sol • 8439 Sunset Blvd., Suite 406 •
West Hollywood CA 90069 • 800-247-7044 • (213) 654-1100

At the last meeting David Dadon from Pegasus Entertainment Talent Agency, INC. approached me about renting some of our precious, classy V 8'S

I could'nt get a word in edge wise, he did all the talking . He asked me for a club roster, I feel this is a better way so you don't get harassed.

This man left his business card on all the cars at the last meeting.

I feel you should know that I've heard many stories about cases of car collectors renting out their cars to the studios and they all have been horror stories.

I urge you to use extreme caution if you should choose to involve your priceless treasures as the studios treat them as "just another prop".

Informatively & Sincerely

SCOOP BLACKWELL



MONTHLY MINUTES OF THE MEETING

ticking away

We had some guests at our last meeting I didn't catch their full names my apologies. They were Jim and Barbara and Chuck with a 1940 Ford.

Ralph Hubbard visiting our group.

Tom Welch has come back and Chuck Temple back.

Gerry Blackwell got up and gave a talk about the tour we had to the desert, BOY THAT WOMAN LOVES TO TALK!!!

Solvang tour coming up, by the time you get this Drive Lines Solvang will be over, SO SKIP IT!!

Thank you to Mary Durkee for the delicious cookies she popped out of her oven in a matter of minutes, you always seem to amaze us Mary and Thanks to Don Durkee for driving them down to us in his convertible Mustang. He drove the mustang to cool them off in time to eat at the meeting.

Next month will be the annual auction with Bill Norton
Please no dirty "J U N K "

The refreshment sign-up sheet will be going around at the next meeting . The same people have been bringing the refreshments, so we would like to have some more volunteers if possible. THANK YOU

Special thanks to Dave Sanborn and Virginia Wolf for the excellent article submitted in last months issue of the drive lines about the life and times of John Wolf.

Parts Call

1940 Ford Convertible Jack Miles

1936 Ford Cabriolet truck hinges sets Dave Sanborn

1966 Ford Mustang Don Durkee

See Ya in a V8

miss V8 
KISS

HOW TO PLAY CARS FULL TIME

by: Harold Hanson

This is a story that to truly enjoy and understand one must be emotionally and physically mature.

Those of you that work with women in your workplace know that occasionally women may say things to you that put a smile on your face and give a shot to your ego. You also know that these same phrases repeated to your wife bring on laughter or sometimes anger.

It all started a few months ago when I went by my office. One of the women on the clerical staff came over to me and whispered a phrase I've been ready to hear for a long time. I was almost certain what she would say but there is always a chance that when two or more people have to come to an agreement one will say no. I also knew she would enjoy using the phrase as much as I would enjoy hearing it. It released a feeling of mixed emotion and excitement in me that I expected but was still more than I had anticipated. In fact, it made me a little bit crazy.

Well, actually a lotta bit crazy because I went home and told Marilyn. She did laugh but she didn't get mad. In fact she wanted to try it. Now I had to come up with a really good reason why something that was perfectly fine and wonderful for me was not for her. First I told her she was too young. This might have worked until she remembered Sam Parker: he's younger than she is and has been enjoying it for years. Next, I told her that if she would wait until she was older she would enjoy it more. This idea seemed to convince her, at least for the time being. This same concept has been used by parents on their children for the last hundred years but it doesn't make any sense at all. Still, it satisfied her.

Now, for those of you mature enough and ready to experience one of the most anticipated parts of life, please substitute your name for mine and enjoy the phrase that woman said to me..."Harold, your retirement has been approved!"

(213) 980-9002



REGIONAL OFFICE

MERCURY SAVINGS

5201 Laurel Canyon Blvd., No. Hollywood, CA 91607-2709  ® 11

Desert wildflowers '87'

5 cars, 9 people and "BIG BAD VIRGINIA WOLF" whom seemed to look so much taller than usual, stated by one of our guests.

Thank you to Doug Peterson Sr. who was our wild flower tour master.

The valley group started their tour from Balboa Park and met up with the group at the Castaic Landing, we proceeded from there.

Doug, with a sudden jerk toured us down one off ramp and right back up the on ramp. We all enjoyed the sight of that wildflower on the side of the road. Thank you Doug Much Appreciated!!!

We stopped along the way at Mojave Airport to see the Voyager. What a sight to see. It wasn't as big as I had pictured especially the cockpit. My only question was, WHERE'S THE BATHROOM?? There was an elderly gentleman, kind of an authority so I asked him. I was determined to find out. Well I got my answer. B O M B S A W A Y !!!!!

As we continued along the poppy reserve, no poppies just moo-cows and baa sheep. Winding down through the mountains and windmills we headed for Tehachapi where there was a town festival waiting for the long caravan of V8's to arrive, out of the mountains they see us and the band started to play and the crowds cheered as we rolled into the dusty old town.

After lunch we toured or should I say skidded and slid around the windy mountain roads (guess who's in the lead Doug P and his suspension) We stopped to see the Tehacapi Loop but the track was broken.

We caravanned out to Bakersfield, or should I say some people drove 80 mph and managed to lose the end car that just happened to be me. I didn't mind because these two cute guys in a 56 chevy showed me the way home. I really knew how to get there but I didn't let them know. Arrived just in time for happy hour and boy were some of us happy.

Dinner that evening at Chateau Basque, great food family style where Pat Culp dazzled us with her charming personality. The V8 choir sang a round of happy birthdays to Bill Culp. Sunday morning after my usual 5 mile light jog we all met for breakfast at the Red Lion Inn the place we all decided to stay in next year.

The last leg of the tour was an afternoon tour of the Pioneer Village an historical town from the 1800's a fascinating place. Acres and acres of old town railroad and what used to be a car collection until a fire came a couple of years ago and wiped out most of the collection. Rumor has it it was arson. We plan to incorporate this into next years tour.

In conclusion the whole weekend was a lot of fun. Thank you Doug for all the hard work you and Durkee put into making this tour. Hopefully next year people will realize that Bakersfield is beautiful this time of year and not turn their noses up like I did last year.

Miss V8

miss
V8
kiss

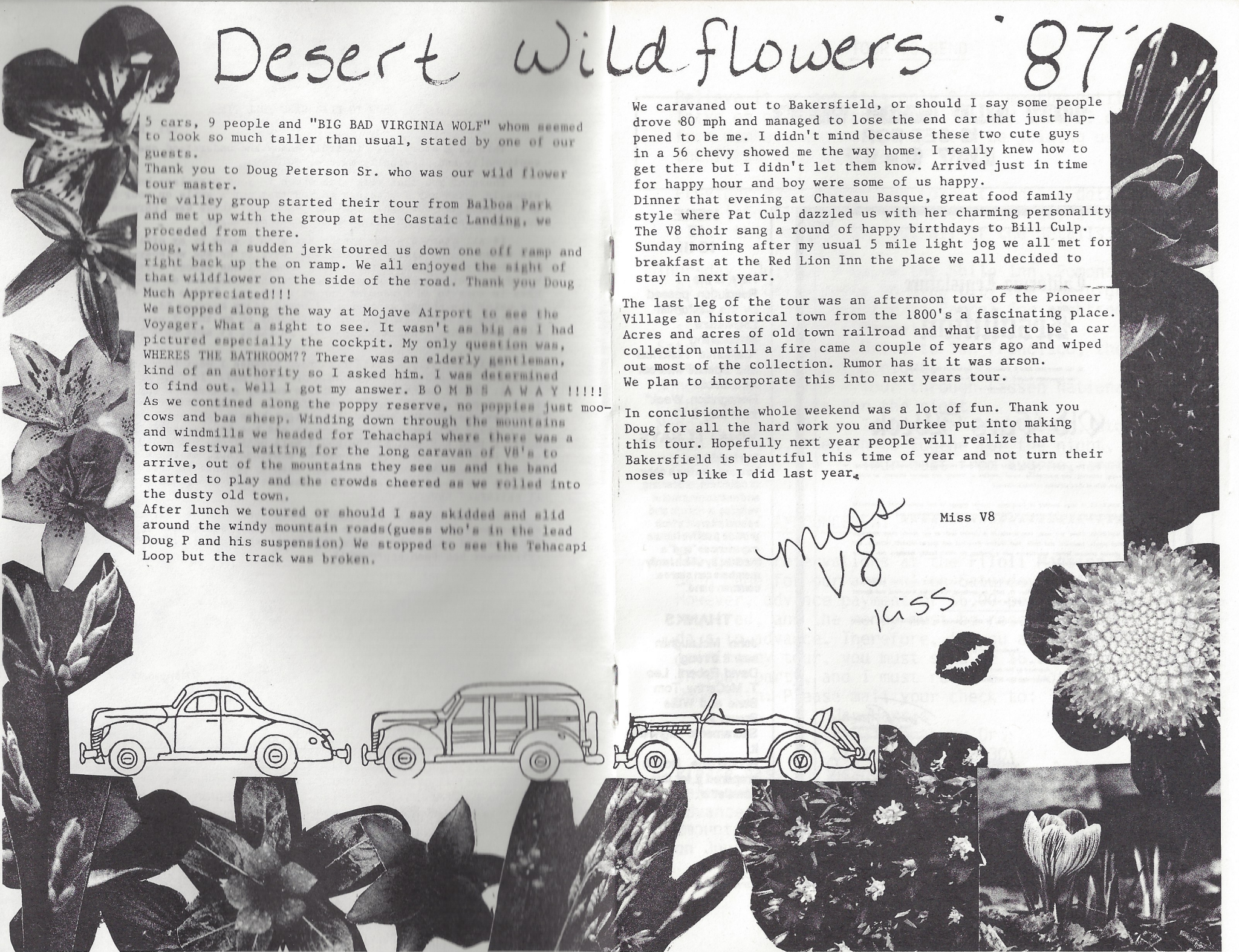
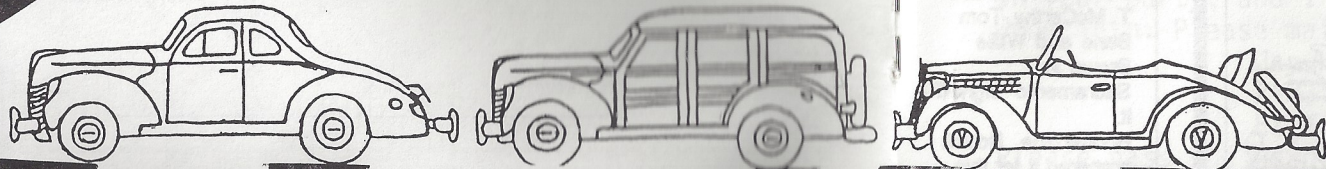

1987 OLD CARS WEEK
IS SET FOR
MAY 9 - 17

California Legislature
Resolution

By the Honorable John T. Doolittle, 1st Senatorial District; and
the Honorable Nolan C. Frizzelle, 69th Assembly District
Relative to

Old Cars Week

WHEREAS, The Legislature of the State of California encourages the hobby of collecting, preserving, restoring, and maintaining motor vehicles of historic and special interest, as stated in Section 5050 of the California Vehicle Code; and

WHEREAS, A large number of California citizens engage in this hobby which contributes to the enjoyment and to the preservation of California's automotive memorabilia; and

WHEREAS, There are many vehicle-related activities such as car shows, swap meetings, interclub meets, concours, and tours, that feature historical and special interest vehicles, and they provide positive leisure experiences and a medium by which family members can share a common bond; now, therefore, be it

RESOLVED BY THE JOINT RULES COMMITTEE OF THE SENATE AND THE ASSEMBLY, That the period of May 9 through May 17, 1987, be declared "California Historical and Special Interest Automobile Recognition Week"; and be it further

RESOLVED, That a suitably prepared copy of this resolution be transmitted to the authors for appropriate distribution.

Resolution No. 122

Approved by the Joint Rules Committee
Subscribed this 9th day of March, 1987

David Roberti
David Roberti, Chairman
Senate Rules Committee

Tom Bane
Tom Bane, Chairman
Assembly Rules Committee

Leo T. McCarthy
Leo T. McCarthy
President of the Senate

Willie Lewis Brown, Jr.
Willie Lewis Brown, Jr.
Speaker of the Assembly



HERE
IT
IS !!!

Here is the Resolution passed by the California Legislature establishing "California Historical and Special Interest Automobile Recognition Week" from May 9-17.

WHAT IT SAYS

The legislature "encourages the hobby of collecting, preserving, and maintaining motor vehicles of historic and special interest which provide positive leisure experiences" and "a medium by which family members can share a common bond."

THANKS

John McLaughlin saw it through
David Roberti, Leo T. McCarthy, Tom Bane and Willie Brown in Sacramento signed it.
Bobbie'dine Rodda prepared it for this newsletter.

TOUR TO BEND

Believe it or not it's only 2 1/2 months until we leave on our tour to BEND! I've had several calls from members who said they will be joining us for the first time this year.

Previous editions of the Fordist contain detailed tour information, so I'll recap each day's travel plans this month, without all of the details:

- Thursday, July 30 - Leave the Shilo Inn, Pomona at 8:30 AM. Drive north to King City for the night.
- Friday, July 31 - - Drive to Carmel for sightseeing-spend the night in Carmel.
- Saturday, August 1 - Drive to San Francisco, then on to Red Bluff for the night.
- Sunday, August 2 - - Tour through Lassen National Park, then on to Yreka for the night.
- Monday, August 3 - - Tour north into Oregon, stopping at Bob Drake's, then on to Eugene for the night.
- Tuesday, August 4 - Tour east from Eugene, arriving at Bend by noon.

IMPORTANT ANNOUNCEMENT *****

The group reservations at the Filoli Mansion have been made for our arrival on Saturday at 11:00 AM. However, advance payment of \$6.00 per person is required, and the money must be received at least 30 days in advance. Therefore, if you are planning on joining my tour, you must send me \$6.00 for each person in your party, and I must receive it not later than June 15th. Please mail your check to:

Jay Harris
21831 Montbury Dr.
El Toro, Ca. 92630

Please pass the word!! I don't want to see anybody left out. The mansion tour is by reservation only, advance payment required. I will send the accumulated amount for our group to the Filoli Mansion people on June 15th, as committed when I made the reservation.

DON'S Auto Parts

MACHINE SHOP and BALANCING

Monday thru Friday 9 a.m. to 8 p.m.

Saturday 9 to 6 - Sunday 10 to 4

Domestic &
Foreign
Parts & Supplies



894-6441

10241 Woodley (At Devonshire), Sepulveda



NEW &
RECONDITIONED

NO. HOLLYWOOD BATTERY

HIGHEST QUALITY FOR MAXIMUM
PERFORMANCE & LONG LIFE

Correct 6 Volt Sizes
For Early V-8's

10748 Burbank Blvd.
No. Hollywood, Ca. 91601
(818) 766-5530

AUTO
TRUCK
MOTORCYCLE
MARINE

CANOGA AUTO PARTS

Serving You Since 1955

RICHARD MATHIESEN

Manager

- DOMESTIC
- FOREIGN
- PAINT & BODY SHOP
SUPPLIES

340-1536

21422 SHERMAN WAY, CANOGA PARK, CA 91303



PRO-CARE AUTOMOTIVE SERVICE

JERRY ALLEN

14700 LULL ST.
VAN NUYS, CA 91405
(818) 908-1413

PROFESSIONAL REPAIRS & PREVENTATIVE MAINTENANCE, ON ALL
MAKES OF CARS & TRUCKS



FOR SALE OF TRADE:

1974 PACESETTER MOTOR HOME 25' G. M

RUNNING GEAR. FULLY SELF - CONTAINED.

6000.00 OR TRADE FOR OLD CAR.

CALL JAN 805-498-0791

EVE. OR WEEKENDS

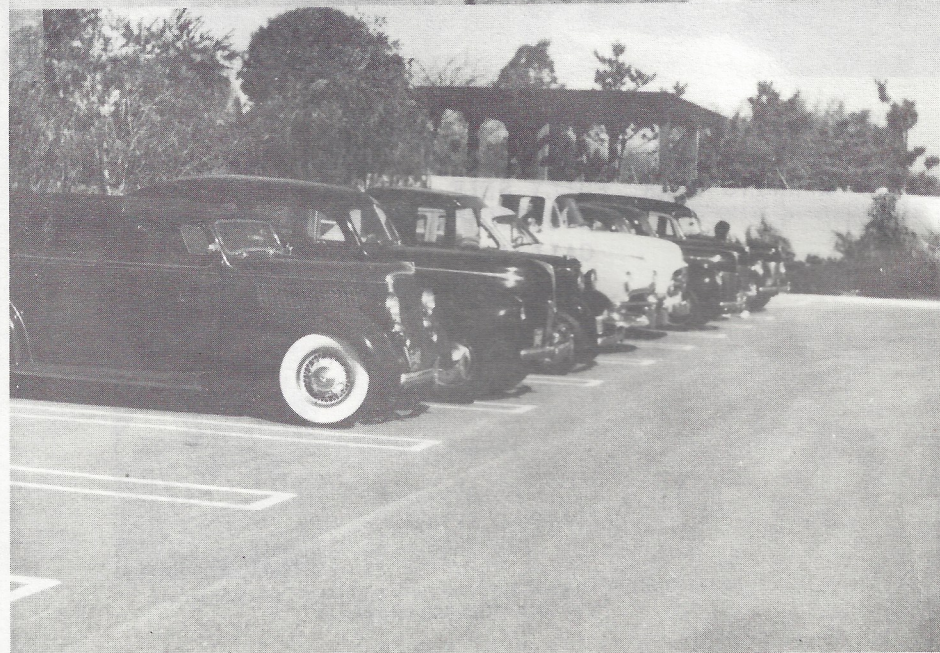



FROM
AUNT JO'S SCRAPBOOK

Compiled by Josephine Cunnington Edwards

CARS CARS CARS

Automobiles were such a rarity when I was a child that when we saw one coming toward us, as we jogged along behind old Dobbin, my father would get out and hold the horse's head and talk gently to him, as he snorted and was frightened.

"They will never come into general use," my father would say. "Oh, yes, a few hot heads will buy them, will get killed, then they will die out. The drivers will be laughed at like that famous 'Darius Green and his flying machine.'"

Yet one of my father's prize possessions was a Model T Ford, and when the Model A came out, he got one and it was his prize possession also.

The world's first automobile is in a museum in Paris. It is called Cugnot's Steam Carriage and was built in 1769. It was used to pull French artillery in the war. An Englishman named Sir Goldsworthy Gurney built a steam carriage and broke all speed records by driving from Bath, England, to London, and back. He averaged the amazing speed of 15 miles per hour. Because of this, England passed what is called the Red Flag Law. It required a man to walk ahead of such a vehicle and wave a red flag. This law was not repealed until 1896.

The first gasoline propelled automobiles were built in the United States by Frank and Charles Duryea in 1892-'93. The next year, Elwood Haynes of Kokomo, Indiana, had the Apperson brothers make one which he had designed.

At first only the rich could afford cars. Then, Henry Ford of Michigan used Eli Whitney's idea of making parts and putting them together to invent the assembly line. He demonstrated a Ford could be assembled in 93 minutes. This put cars in a lower price bracket, so middle-class America could afford them.

By 1900, there were 8,000 cars in use in the world. It is said that a farm woman in Kansas was asked why her family owned a car and not a bathtub. She answered, "Why, you can't go to town in a bathtub!"

Submitted by Mary Nord Cramer

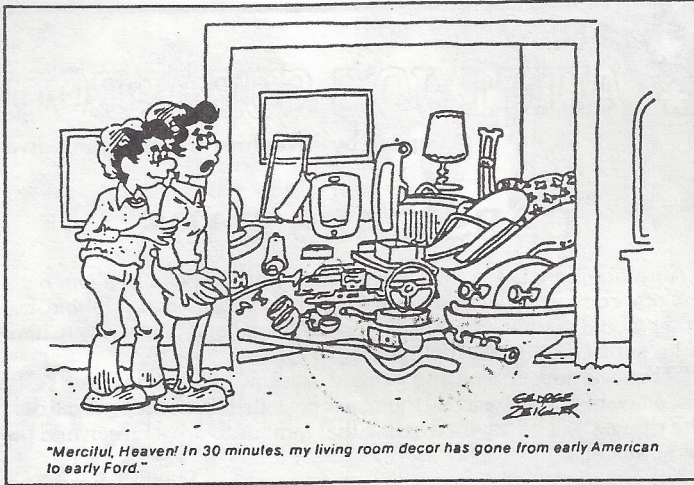

Taken from Golden Gate Regional Group

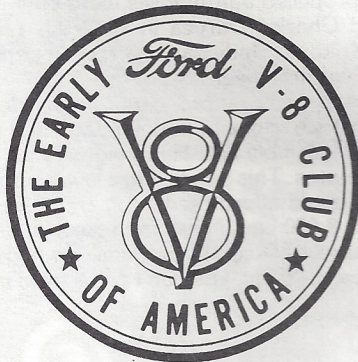

PAST PRESIDENT

JIM ROWE.....	1971-72
DOUG PETERSON.....	1972-73
DON DURKEE.....	1974
ED WARNOCK.....	1975
JOHN BUSK.....	1976
CHIP WERSTEIN.....	1977
STAN MASRAJE.....	1978
BOB DRAKE.....	1979
BILL CULP.....	1979
AL SPENCER.....	1980
LARRY CAPLAN.....	1981
BOB ROSE.....	1982
DON DURKEE.....	1983
PAUL KIRK.....	1984
KENT LOWRY.....	1985
DAVE SANBORN.....	1986

The Valley  **'s**

P.O. BOX 96 - RESEDA, CA 91335

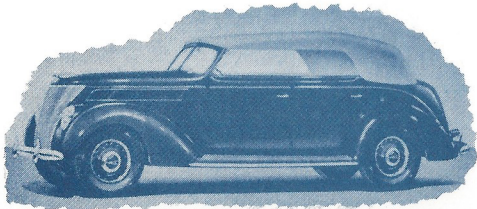
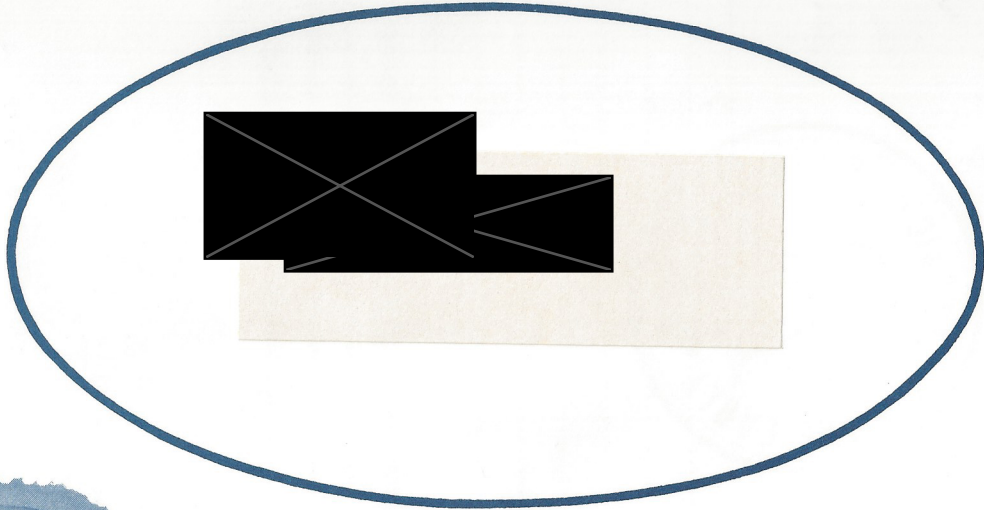

50th Anniversary