

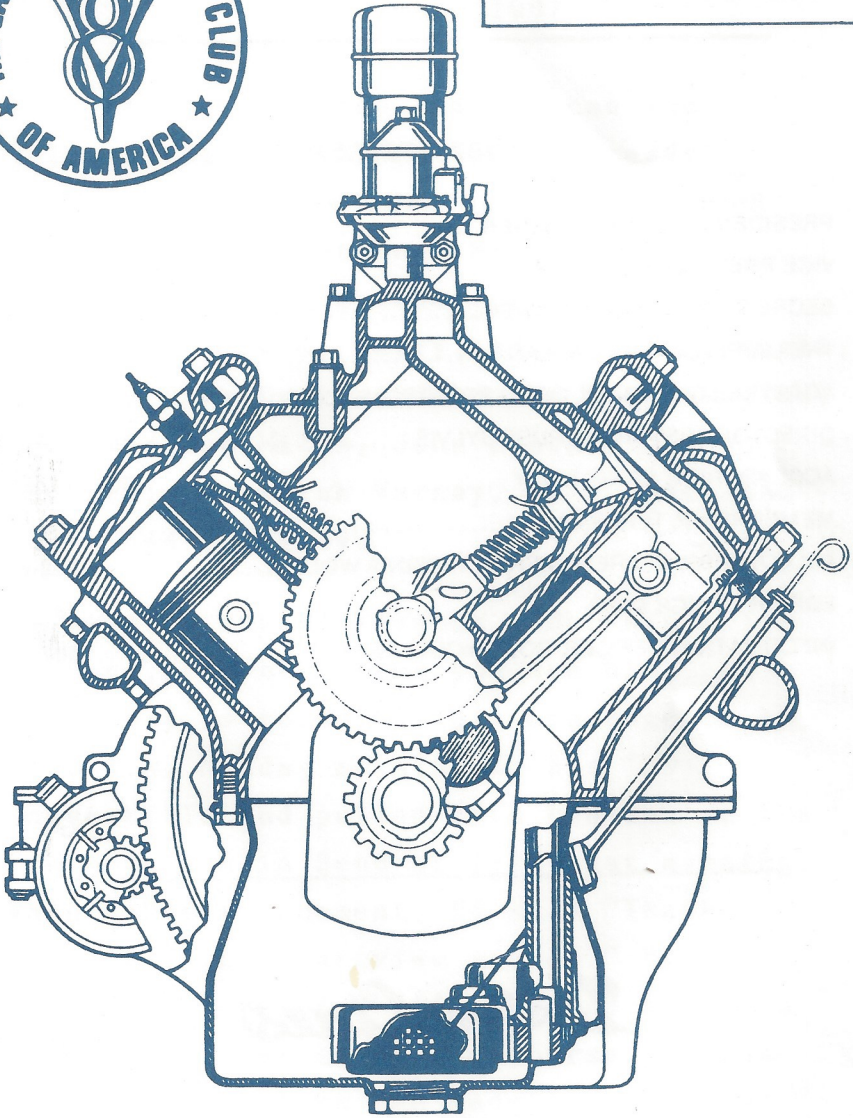

SEPTEMBER



Drive Lines

The Valley 's

1987 OFFICERS

PRESIDENT, JOHN KEMMERER	843-2138
VICE PRESIDENT, PAT BERRY	848-5466
SECRETARY, JULIE BLACKWELL.....	(805) 499-1021
TREASURER, LARRY CAPLAN.....	363-2849
ACTIVITIES CHAIRMAN, DOUG PETERSON	703-0738
DIRECTOR, HISTORIAN, RUSS SYLVIS	(805) 527-4387
ACCESSORIES, ERNIE BAILY	(805) 522-9674
MEMBERSHIP, TERRY SMITH.....	989-3119
FELLOWSHIP, REFRESHMENTS, VIRGINIA WOLF	789-6201
EDITOR, CHUCK MAIR	785-9413
INFORMATION OFFICER, BOB McCULLAGH.....	886-2644

Drive Lines

Published by

SAN FERNANDO VALLEY CHAPTER 40
of the EARLY FORD V8 CLUB of AMERICA

P.O. Box 96
RESEDA, CA. 91335

COVER/ROY JONES

Valley V-8s
September 1987

What happened to the summer, can you believe that it is September already?

— The Valley V-8s were well represented at the Western National Meet in Bend, Oregon. Attending from our club were : Pat Berry, Bruce, Gerry, and Julie Blackwell, Don and Mary Durkee, John and Lin Kemmerer, Jack and Ann Miles, John Rosema, Dave Sanborn, Christine Varney, Ed Warnock and Jerry and Jo Veley.

Be sure to ask Ed Warnock about his drive to Bend, the next time you see him. As the story is told, Ed left Los Angeles at 5:00 A.M. Monday morning in his '39 Convertible and pulled into the Inn of the 7th Mountain in Bend at 7:15 that evening. When asked to comment, Ed said "Thank Henry for the rear view mirror." By the way, after scraping off the dead bugs, Ed entered his car in the concourse and was awarded a Dearborn V-8 Medallion. Dave and Christine also received Dearborn V-8 Medallion awards for their '35 Tudor and '35 Phaeton. In the touring competition Bruce and Jerry Blackwell received second

and third place awards for their '40 coupe and '36 roadster. — Pat Berry took a lot of photographs of the tour and meet and will have them at the pizza night. A few of Pat's pictures will probably be included elsewhere in the Drivelines.

Speaking of Pat - What a tremendous job he did putting together our chili cookout at Wheeler Springs. Pat is one of several unsung hard workers in the club that are constantly busy behind the scenes to keep things running smoothly and make the President's job easier. Pat has a real "Can Do !" attitude and is never too busy to lend a hand. Thanks Pat.

John and Bonnie Busk have things well in hand for our annual Pizza night which will be held at Mancini's Resturant on the corner of Roscoe and Desoto (20923 Roscoe Blvd) in Canoga Park. The Valley V-8s will receive 10% of the proceeds from the restaurant that evening. We want to have the club well represented, so dust off your car bring a big appetite, and plan on arriving about 6:00 P.M. on Monday September 14th. Remember, because of Pizza night and Labor Day weekend, we will not have a regularly scheduled September meeting, but will be

- Valley V-8's Monthly Meeting
7:00 p.m. Mercury Savings
5201 Laurel Canyon Blvd.
Studio City, CA

- September 14 - Busk's Annual Pizza night and
car show at Mancini's 20923
Roscoe Blvd Canoga Park
- 25-27 - Pismo '40 Fest
- 27 - Antique Auto Parts Exchange
G.M. Plant Van Nuys
- October 4 - All Ford Picnic La Palma Park
Anaheim
- October - Dave Sanborn's Quad Clubs'
Breakfast
- November 14 - Merle Norman - San Sylmar Tour
- December 4 - Installation Dinner and
Christmas party - Al and Ruth
Spencer

Thanks to Gerry Blackwell for coordinating
our tours and events. - Contact Gerry for
details on any of the events.

Don't Be Afraid To Fail

You've failed
many times,
although you may not
remember.

You fell down
the first time
you tried to walk.
You almost drowned
the first time
you tried to
swim, didn't you?

Did you hit the
ball the first time
you swung a bat?
Heavy hitters,
the ones who hit the
most home runs,
also strike
out a lot.

R. H. Macy
failed seven
times before his
store in New York
caught on.

English novelist
John Creasey got
753 rejection slips
before he published
564 books.

Babe Ruth struck out
1,330 times,
but he also hit
714 home runs.

Don't worry about
failure.

Worry about the
chances you miss
when you don't
even try.

28 CAUSES OF OVERHEATED MOTORS

- 1) Rings fitted too tight.
- 2) Thick rings in shallow grooves.
- 3) Clogged radiator.
- 4) Clogged hose and connections.
- 5) Clogged cylinder block and passages with sludge scale and rust.
- 6) Clogged muffler and pipes.
- 7) Right pistons.
- 8) Right piston pins.
- 9) Right main or connecting rod bearings.
- 10) Faulty ignition.
- 11) Ignition timing late.
- 12) Valve timing incorrect.
- 13) Defective condenser.
- 14) Defective coil.
- 15) Burnt ignition points.
- 16) Defective spark plugs.
- 17) Leak in high tension wire assembly.
- 18) Improper lubrication.
- 19) Lack of lubrication.
- 20) Improper carburetion.
- 21) Too much carbon in combustion chamber.
- 22) Loose, broken or slipping fan belt.
- 23) Air passages of radiator stopped with dirt or insects
- 24) Stuck automatic spark control.
- 25) Faulty thermostat in motor or shutter.
- 26) Pump speller slipping on shaft.
- 27) Dragging brakes.
- 28) Low water level due to leakage.

Thank you to Dan Krehbiel for supplying us with this great technical article.

all **FORD** picnic

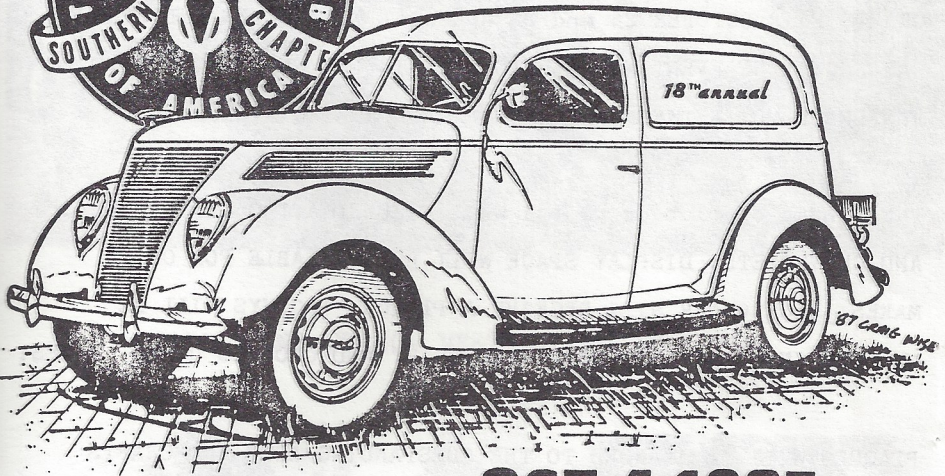

OCT. 4, 1987

La palma park - anaheim, ca

\$7.00 PER CAR SHOW
REGISTRATION —
INCLUDES DASH PLAQUE

9 A.M. - 3 P.M.

RAFFLES — PRIZES

TROPHIES
(Increased Classes)

SPECTATORS FREE

- HOT DOGS
- SOFT DRINKS

For More Information:
JOE SCANLIN -213-438-4292

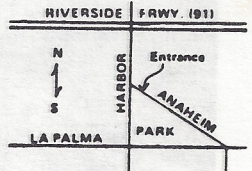

ROTARY CLUB
ENCINO ART & CRAFT FAIR
and
ANTIQUÉ CAR
SHOW

SATURDAY AND SUNDAY

OCTOBER 24, 25, 1987

THE ROTARY CLUB OF ENCINO WILL HOLD ITS ANNUAL ARTS AND CRAFTS FAIR OCTOBER 24 and 25 AND WILL FEATURE AN ANTIQUE CAR SHOW. THE EVENT WILL BE LOCATED IN THE ENCINO PARK ON VENTURA BLVD. BETWEEN PASA ROBLES AND ENCINO AVENUE.

THE (name of club or clubs) WILL BE DISPLAYING VINTAGE FORD AND CHEVROLETS. DISPLAY SPACE WILL BE AVAILABLE FOR OTHER MAKES. EACH OWNER WILL RECEIVE A PLAQUE. TROPHYS WILL BE AWARDED IN 3 CLASSES, FORD, CHEVROLET AND GROUPED OTHER MAKES.

PLAQUES WILL BE AWARDED TO THE OUTSTANDING ARTS AND CRAFTS EXHIBITS.

GUARD SERVICE OVERNIGHT WILL BE FURNISHED BY THE ROTARY CLUB AND THE LAPD EXPLORER SCOUTS. FREE PARKING, 1 SHORT BLOCK WEST AT HOME SAVINGS AND LOAN, WILL BE AVAILABLE FROM 12 O'CLOCK SATURDAY. VALET PARKING SERVICE TO EXHIBITERS AT THE ROTARY INFORMATION BOOTH. FREE SHUTTLE SERVICE (ROTARY VAN WITH SIGNS) WILL BE AVAILABLE TO THE PUBLIC. ETHNIC AND THE USUAL AMERICAN FOOD AND DRINKS WILL HAVE BOOTHS.

APPLICATIONS ARE NOW BEING TAKEN. CONTACT MIKE COX 818 781-3000 OR CY BREEN 818 881-0611 (999-6808 eves.) FOR FURTHER INFORMATION. OR Joe D. FATTA (818) 781-8283



PHOTOS BEND OREGON MEET





THE ABOVE YOUNG MAN LOOKS SAD BECAUSE HE MISSED THE LAST V8 MEETING AND HIS NAME WAS DRAWN FOR BIG MONEY.





BRIEFLY SPEAKING

Cars of the future

Members of the Detroit chapter of the Society of Automotive Engineers were asked recently to project what cars will look like in 2011. Seventy percent thought auto bodies would be plastic. Sixty-two percent thought the vehicles would be streamlined, but with smooth, flowing edges, like a teardrop; 20 percent predicted wedgelike shapes with sharp angles.

Piston-driven engines will still be around, said three-quarters of those who responded; 12 percent foresaw turbine engines. Rear-wheel drive will be obsolete, the engineers said. Cars will have either front-wheel drive or four-wheel drive.

Roughly seven of 10 engineers believed cars would still require human hands to steer, but 16 percent expected a combination of driver control and automatic guidance.

So there you have it: Just bolt a Ford Taurus engine to a Jeep Cherokee chassis, cover it with a Chevrolet Corvette body and install the instrument panel from a Beechcraft.

DON'S Auto Parts

MACHINE SHOP and BALANCING

Monday thru Friday 9 a.m. to 8 p.m.

Saturday 9 to 8 - Sunday 10 to 4

Domestic &
Foreign
Parts & Supplies



894-6441

10241 Woodley (At Devonshire), Sepulveda



NEW &
RECONDITIONED

NO. HOLLYWOOD BATTERY

HIGHEST QUALITY FOR MAXIMUM
PERFORMANCE & LONG LIFE

Correct 6 Volt Sizes
For Early V-8's

10748 Burbank Blvd.
No. Hollywood, Ca. 91601
(818) 766-5530

AUTO
TRUCK
MOTORCYCLE
MARINE

CANOGA AUTO PARTS

Serving You Since 1955

RICHARD MATHIESEN

Manager

340-1536

21422 SHERMAN WAY, CANOGA PARK, CA 91303

- DOMESTIC
- FOREIGN
- PAINT & BODY SHOP
SUPPLIES



PRO-CARE AUTOMOTIVE SERVICE

JERRY ALLEN

14700 LULL ST.
VAN NUYS, CA 91405
(818) 908-1413

PROFESSIONAL REPAIRS & PREVENTATIVE MAINTENANCE, ON ALL
MAKES OF CARS & TRUCKS

PAST PRESIDENT

JIM ROWE.....	1971-72
DOUG PETERSON.....	1972-73
DON DURKEE.....	1974
ED WARNOCK.....	1975
JOHN BUSK.....	1976
CHIP WERSTEIN.....	1977
STAN MASRAJE.....	1978
BOB DRAKE.....	1979
BILL CULP.....	1979
AL SPENCER.....	1980
LARRY CAPLAN.....	1981
BOB ROSE.....	1982
DON DURKEE.....	1983
PAUL KIRK.....	1984
KENT LOWRY.....	1985
DAVE SANBORN.....	1986

The Valley  **'s**

P.O. BOX 96 - RESEDA, CA 91335

VALLEY NUYS, CA
DIA
SEP 2
1987
91A

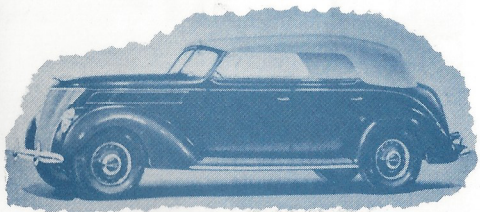
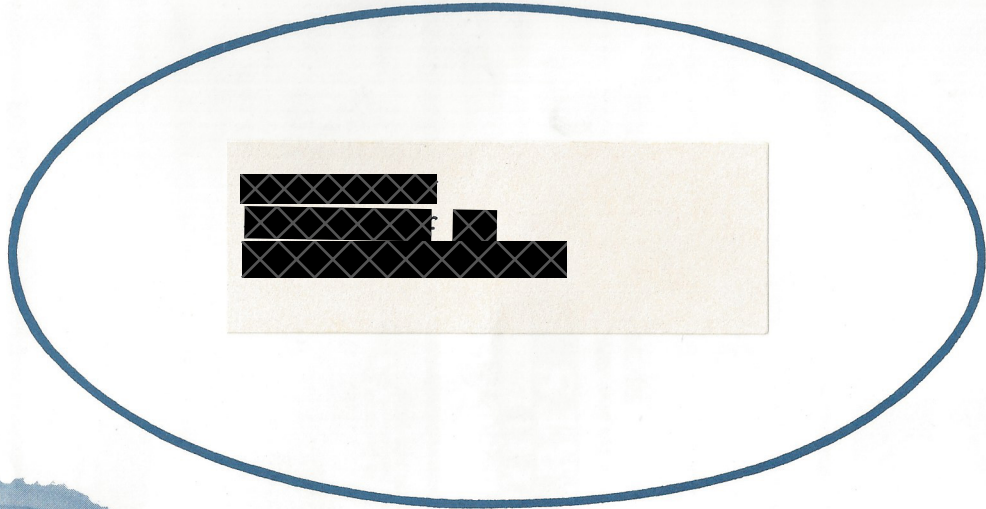

50th Anniversary