

93

DECEMBER

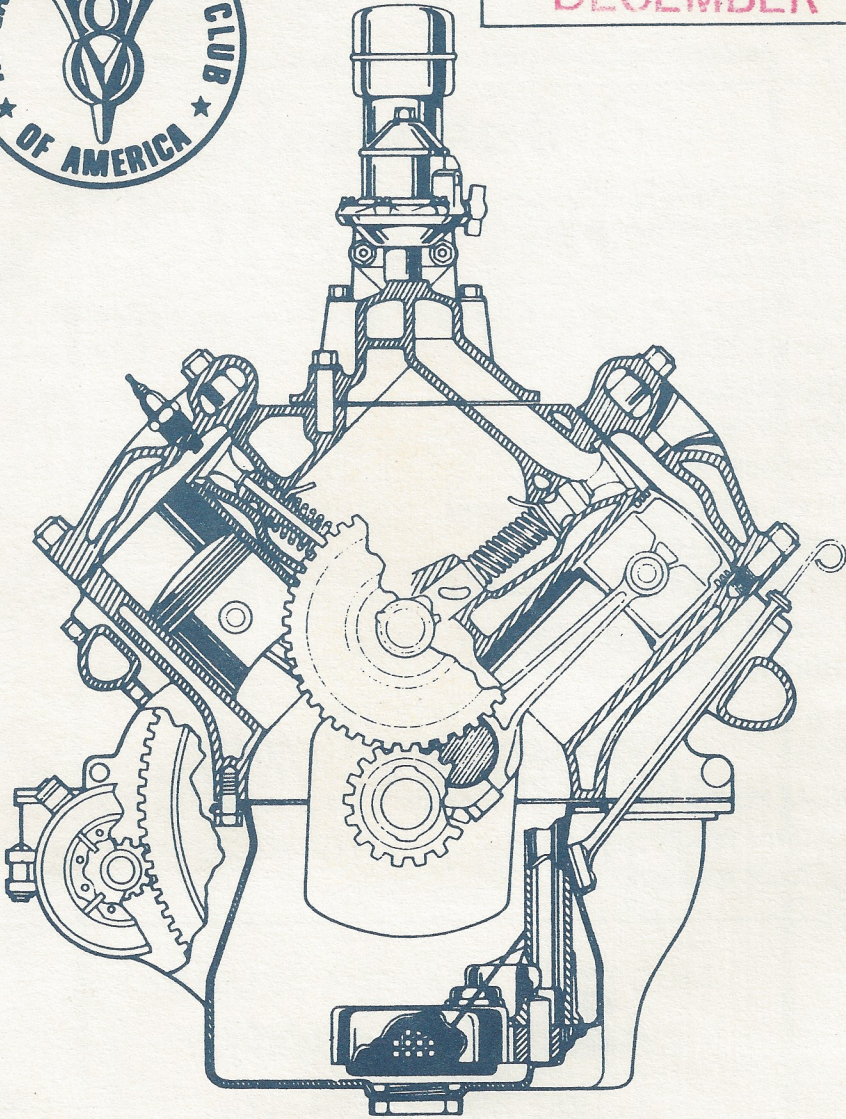

Drive Lines

The Valley 's

1993 OFFICERS

PRESIDENT, Chuck Shubb.....	(818) 882-2927
VICE PRESIDENT, George Richards.....	(818) 992-4537
SECRETARY, Chuck Mair.....	(818) 785-9413
TREASURER, Jerry Littner.....	(818) 347-1194
ACTIVITIES, Jim Winnett.....	(818) 768-4228
ACCESSORIES, Lee Wright.....	(818) 846-4906
MEMBERSHIP, Terry Smith.....	(818) 989-3119
FELLOWSHIP, Virginia Wolf.....	(818) 789-6201
RAFFLES / HISTORIAN, Lloyd Paschal.....	(805) 527-6464
EDITOR, Lesley Littner.....	(818) 347-1194
ASSISTANT EDITOR, Joe DiFatta.....	(818) 782-9883
PROGRAMS, John Kemmerer.....	(818) 843-2138
TECHNICAL ADVISOR, Don Dupree.....	(818) 883-2747

1993 Committee Chairmen

ANNUAL PEPPERMILL, George Richards.....	(818) 992-4537
CHRISTMAS PARTY, Al Spencer.....	(818) 761-1734
DIRECTORY, Paul Kirk.....	(818) 886-5467

Drive Lines

Published By

SAN FERNANDO VALLEY CHAPTER 40
of the EARLY FORD V8 CLUB OF AMERICA

P.O. Box 96
Reseda, CA 91335

COVER/ROY JONES

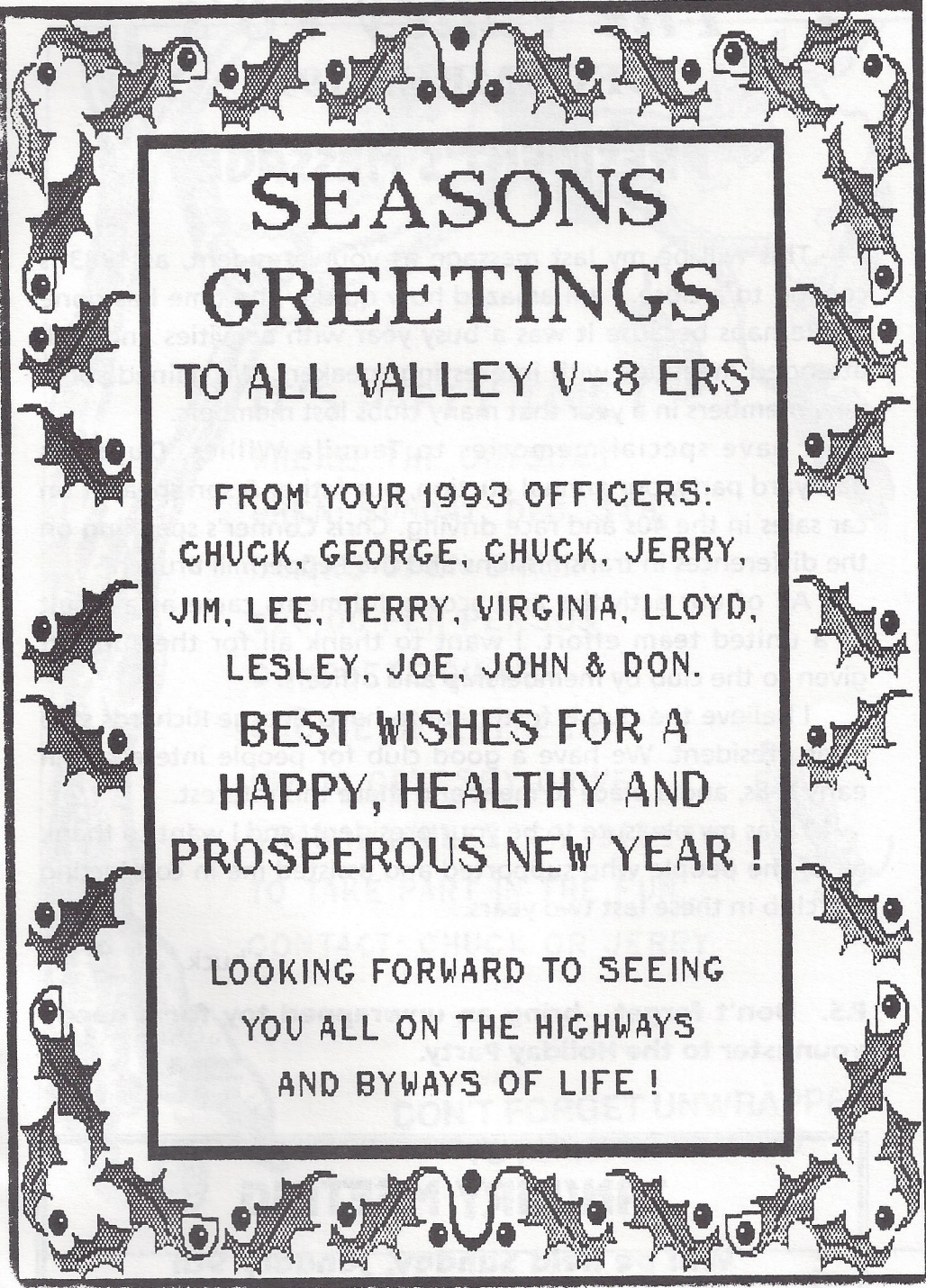

SEASONS GREETINGS

TO ALL VALLEY V-8 ERS

FROM YOUR 1993 OFFICERS:
CHUCK, GEORGE, CHUCK, JERRY,
JIM, LEE, TERRY, VIRGINIA, LLOYD,
LESLEY, JOE, JOHN & DON.

BEST WISHES FOR A
HAPPY, HEALTHY AND
PROSPEROUS NEW YEAR !

LOOKING FORWARD TO SEEING
YOU ALL ON THE HIGHWAYS
AND BYWAYS OF LIFE !

The Valley V8's

DECEMBER 1993

PRESIDENT'S MESSAGE

This will be my last message as your president, as 1993 is coming to a close. I am amazed how quickly the time has gone by. Perhaps because it was a busy year with activities and well attended meetings with interesting speakers. We gained some new members in a year that many clubs lost members.

I have special memories to Tequila Willies, Dupree's backyard party, our annual auction, our father & son speaker on car sales in the 40s and race driving. Chris Conner's speaking on the differences in transmissions and the Peppermill Brunch.

All of our activities and accomplishments came as a result of a united team effort. I want to thank all for the support given to the club by membership and officers.

I believe the club is fortunate to have George Richards step in as president. We have a good club for people interested in early V-8s, and a place to meet and share this interest.

I was my pleasure to be your president, and I want to thank all of the people who supported and assisted me in conducting the club in these last two years.

Chuck

P.S. Don't forget - bring an unwrapped toy for a needy youngster to the Holiday Party.

JANUARY MEETING

Will be held Sunday, January 9th



IT'S PARTY TIME !

WHERE: THE ODYSSEY

WHEN: SUNDAY, DEC. 5TH

DOORS OPEN 6 P.M.

\$20.00 PER PERSON

COMPLETE DINNER

CHOICE OF ENTREES.

15600 ODYSSEY DRIVE

GRANADA HILLS, CA. 91344

TO TAKE PART IN THE FUN...

CONTACT: CHUCK OR JERRY

**DON'T FORGET UNWRAPPED
TOY FOR NEEDY KID**



DECEMBER 5-8 BIRTHDAYS

12/3 JO VELEY

12/6 DAVID SATEL

12/6 GEORGE RICHARDS

12/9 NANCY BEAUREGARD

12/11 SHEL HARRIMAN

12/15 KEN SAPPER

12/19 SHIRLEY RICHARDS

12/19 JAY FORTMAN

12/20 JIM LOMBARDO

12/27 DONNA PASCHAL

12/28 GREG PETROSYAN

12/31 JIM FOWLER

FORD KEEPS TRUCKIN'



Ford made V-8 trucks, as it did cars, starting in 1932. Their classic look make them as popular today as when they were first sold. In the 1942 model year, a Ford truck could be purchased in one of 126 classic-body-engine combinations. 1942 was a special year for Ford pickups: the bed was 3" wider; the fenders, hood, grill and cab were all new; the six-cylinder engine was now an option along with two V-8's and a four-cylinder. As a result of World War II, truck designs were frozen for six years and the basic 1942 configuration endured through 1947.

This handsome ad, showing an Art Deco influence, was used to introduce the new line of Ford trucks for 1942. Not the parking light on the fender...it made an appearance later on the front fenders of 1947-48 automobiles.

Reprinted from the Greyhound Gazette.

WHERE YOUR SODA POP BOTTLES GO...SURPRISE!

That plastic soft drink bottle you just dropped in the recycling bin may be part of your car's bumper next time around. Not just any recycled bottle will do. Ford Motor Company since 1988 has used "PET" (polyethylene terephthalate), a plastic resin, which comes from those soft drink bottles. The bottles are compacted, bailed and shipped to a recycling company in Pennsylvania, where they are ground, cleaned and pelletized. The pellets are processed and combined with 35 percent glass and mineral to produce plastic used by Ford. And each part can be recycled again. Ford has used more than 23,000,000 pounds of PETRA (made by Allied-Signal) during the past five years. More than 1,000,000 Ford cars and trucks annually are using parts made from recycled soft drink bottles.

(From an article originally published by the "FORD LINES" of the Tulsa V-8 Club)

Chuck Mair's

SECRETARY'S VIEWPOINT

With President Chuck Shubb on a movie set in Arizona and Vice President George Richards out of town, we were all left in very capable hands; under the directions of Past President Joe DiFatta and Treasurer, Jerry Littner. Joe, in his friendly and personal style, warmly greeted the visitors and conducted the meeting while walking in front of our seated club members.

Each member and visitor introduced themselves and told which old car they owned.

Jim Winnett's daughter had Girl Scout candy for sale.

Blacky Blackwell gave a report on the Blackwell Weekend Tour, with a turn out of twenty-three cars.

Jerry Littner thanked the members for bringing food items to be donated to the needy.

We also had a frozen turkey to be raffled off.

Our Christmas dinner will be at the Odyssey Restaurant, Sunday, December 5th at 6:00 p.m. Drive your old car. Bring an unwrapped toy or gift. If you haven't yet, get your \$20 per person to Jerry Littner fast.

The response was underwhelming, for volunteers asking for a new editor.

We had our coffee break, with some homemade cookies – then introductions of our speakers, Bernie & John Calvert, a father and son. The father (Bernie), a Ford dealer in the 30's and 40's, and the son (John) is a stock eliminator champion race driver.

Hats off to our program chairman for another excellent program. Come on out and support your club, join in on the fun and tours.

Eleven old cars driven and thirty-five members present.

Chuck Mair

CARS & PARTS FOR SALE

ITEM	Name / Phone
30 "A" motor & trans & rear end	Mike Munroe 789-7225
Car trailer tandem axle	H. Johansen (818) 784-1068
670-15 tires like new - truck or car	Ben DiFatta (818) 716-5583
'53 Ford Convertible #2 Cond - \$9,500	Roger 908-1428
1942 Chevy 1/2 Ton Pickup - \$3,000	Jim Hannon (818) 705-8916
1938 Dodge 1/2 Ton Pickup - \$650	Hollis Cotton (818) 246-0671
1966 Pontiac GTO 49M orig. miles, wht/blk interior Tri power, P.S. P.B., air cond., show condition - \$12,500 OBO	Jim (818) 222-7994
1935 Ford Roadster ground-up, 90% completed \$13K	Chuck (818) 882-2927
'34 Ford hood - complete, good shape	Jack (818) 784-3746
1935 Transmission - all rebuilt \$250	Len Widders (818) 993-0768

CARS & PARTS WANTED

ITEM	Name / Phone
1957 Ford Fairlane 500 2dr.	Michael Roche (818) 774-0004

Simi Valley Corvette Club

7TH ANNUAL

SIMI VALLEY CARE AND SHARE CHARITY CAR SHOW

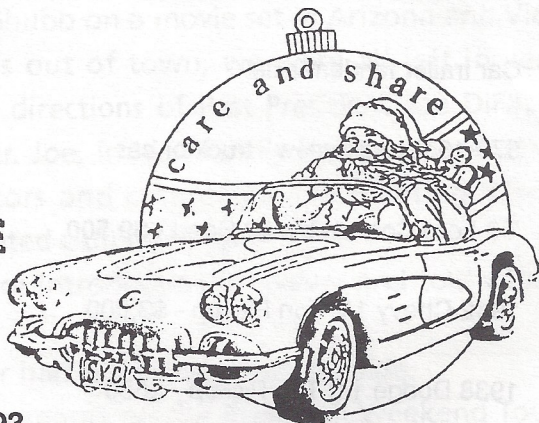

SUNDAY DECEMBER 5, 1993
10:00 a.m. - 3:00 p.m.

To be raffled,
1940's gas
pump

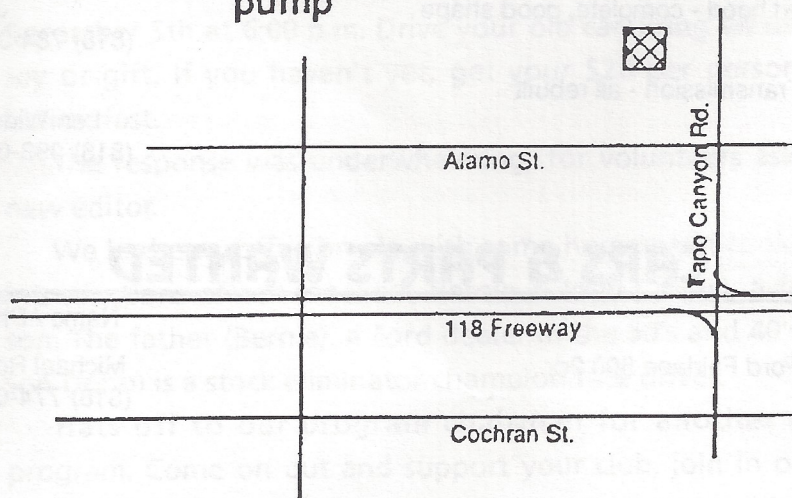

To be held at: Simi Valley City Hall
2929 Tapo Canyon Rd.

LETTER FROM ANN LANDERS

Car: Junk to wife, husband's treasure

Dear Ann: I have been married for three years to the most wonderful man. I would not trade him for anything. However, there's one thing about this guy that bothers me a lot, and I'm afraid to bring it up.

"Luke" owns a car. It's old, it's ugly, and it hasn't run in years. I'm sure that at one time it was pretty sensational, but it would take a lot of time and a ton of money to make it that way again. Before we were married, this car took up space in his parents' garage. We towed it to our first residence and then had it towed again to our present home, where it sits in the garage.

Ann, Luke hasn't worked on this car in years. Because of money constraints and the possibility of having children soon, I don't believe he will ever get this piece of junk running. Meanwhile, it takes up space that we could use. Luke's family and I have despaired of bringing up the subject without risking a big fight. He is very sensitive about it.

I know this car represents something important to my husband, but I wish it weren't such an albatross. How do I persuade him that it's time to let it go and move on?

– Take My Car, Please!

Dear T.M.C. Please: Accept the old Katrinka as a permanent albatross. You don't have to feed it. Sounds as if your husband has an emotional attachment to the old rattletrap that defies logic.

(Maybe he should join the Valley V-8's)

**WISE MAN SAY:
IT'S TIME TO PAY YOUR
1994 ANNUAL CLUB DUES.**

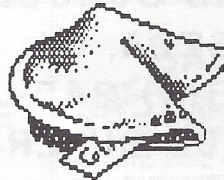

**\$20. WILL BUY 12 MONTHS
OF HAPPY V-8ing.**



"Hey, I'm not *crazy*. ... Sure, I let him drive once in a while, but he's never, *never* off this leash for even a second."

A VALLEY V-8 WELCOME
TO OUR NEW MEMBERS:
AL AND LUANNE ROHRER

19218 SCHOOLCRAFT
RESEDA, CA. 91335
(818) 345-3721

PROUD OWNERS OF A:
1934 DELUXE 4-DOOR SEDAN.

SUPPORT OUR ADVERTISERS!

DiFATIA
Graphics

Specializing in
Complete Quality Printing

5920 LEMONA AVENUE • VAN NUYS, CA 91411
(818) 782-9883

Flips
TIRE CENTER

FLIP SMITH

Formerly
GLOBE TIRE

7735 Sepulveda Blvd.
Van Nuys, CA 91405
(818) 786-8686

DON'S
Auto Parts

MACHINE SHOP and BALANCING

Monday thru Friday 8 a.m. to 7 p.m.
Saturday 9 to 6 - Sunday 10 to 4

10241 Woodley (At Devonshire)

Domestic &
Foreign

Parts & Supplies



(818)
894-6441

Sepulveda, CA 91343

RAFFLE PRIZE DONOR

DAVID'S
VENDING
SALES AND SERVICE

DISTRIBUTOR FOR:

Cavalier
WITTENBERG

LETTRO-VERD
BREWOMATIC
HAMILTON

COINCO • *Amens*
800 S. San Fernando Blvd
Burbank, California 91502

(818) 848-8703

DAVID SATEL

Older Cars
A Specialty

4 x 4's and
Motorhomes

Russell Sylvis, Inc.

Transmissions
Repaired • Rebuilt

(805) 527-4387

4657 Barnard St.
Simi Valley, CA

R.C. Smith's
Roofing Solutions

Roofing & Waterproofing • Complete Maintenance Service

8707-D Lindley Ave., Ste. 199, Northridge, CA 91325
Lic. #356650 **(818) 718-2313**

Auto • Homeowners

- ANTIQUE CARS -

ED HARDIN INSURANCE

Business • Life • Health • Aircraft



Call us for your Insurance needs!

(818) 363-7864

BATTERY TENDER
~~\$45.00~~
~~1/8 club price \$49.95~~

THE SAFE AND RELIABLE WAY TO KEEP YOUR
CAR BATTERY AUTOMATICALLY CHARGED UP
AND ALSO EXTEND ITS LIFE.

6 VOLT OR 12 VOLT MODELS
(\$59.50 AFTER DEC. 93)

ALLAN FRANKLIN
(818) 842-2230

SUPPORT OUR ADVERTISERS!

L.T. "LEE" SAWYER, INC.

Jobber
Shell Oil and Chemical Products

14117 Aetna Street, Box 369
Van Nuys, California 91408

TOM SAWYER (818) 786-8180 / (818) 785-0902

RAFFLE PRIZE DONOR

The Prudential



California Realty

13400 Ventura Blvd.
Sherman Oaks, California 91423
Bus. (818) 788-5400
Res. (818) 761-1734
Fax. (818) 784-4926

AL SPENCER
Broker Consultant



RESIDENTIAL • COMMERCIAL

KELLY ELECTRIC

ELECTRICAL CONSTRUCTION • MAINTENANCE

DAVE KELLY
ST. LIC # 657067

(818) 773-8997
(805) 255-6905

R.E. SALES

LOAN CONSULTANT

Ben F. DiFatta

MORTGAGE BROKER
LICENSED CA. DEPT. OF R.E. BROKER

23534 CANDLEWOOD WAY, WEST HILLS, CA 91307
PHONE/FAX 818-716-5583 PAGER 818-831-4567

CHRIS CONNERS' Ancient Transmission Repair



Specializing in Standard Ford Transmission Rebuilding
THREE SPEEDS • FOUR SPEEDS • OVERDRIVES
(310) 618-1586

Antique Car Radio
Repairs & Restoration

Over 50 Years
Experience

NORB FOURNIER

Van Nuys Antique Radio

13133 Weddington St.
Van Nuys, Ca. 91401

(818) 784-5836

BEV DUPRÉE

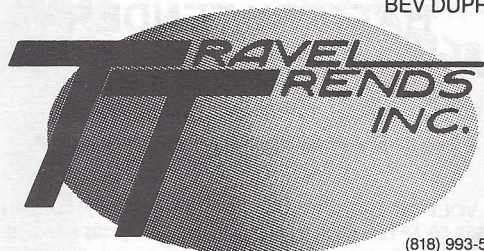

8902 1/2 RESEDA BLVD.
NORTHRIDGE, CA 91324

(818) 993-5400
FAX (818) 993-3972
HOME (818) 883-2747

JAMES R. GARY & Co. Ltd.

REALTORS® & ESTATE AGENTS

DON ROSS, CREA

CERTIFIED REAL ESTATE APPRAISER
REALTOR-ASSOCIATE*

21747 Erwin Street
Woodland Hills, CA 91367-3699

Bus: (818) 703-6100
Res: (818) 998-6594
Fax: (818) 703-1870

PAST PRESIDENTS

JIM ROWE.....	1971
DOUG PETERSON	1972
DON DURKEE	1974
ED WARNOCK	1975
JOHN BUSK.....	1976
CHIP WERSTEIN	1977
STAN MARSRAJE	1978
BOB DRAKE	1979
BILL CULP.....	1979
AL SPENCER.....	1980
LARRY CAPLAN	1981
BOB ROSE	1982
DON DURKEE	1983
PAUL KIRK	1984
KENT LOWRY	1985
DAVE SANBORN.....	1986
JOHN KEMMERER	1987
DUDLEY OCHSNER.....	1988
JERRY JENSEN	1989
JERRY JENSEN	1990
JOE DiFATTA.....	1991
CHUCK SHUBB.....	1992

Meetings are held on the first Sunday of every month at 7:00 p.m.

The Valley  **'s**

P.O. BOX 96 — RESEDA, CA 91335

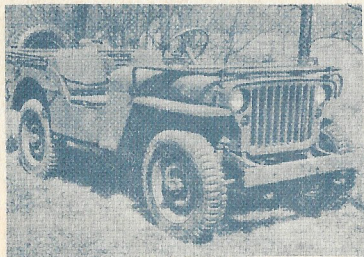
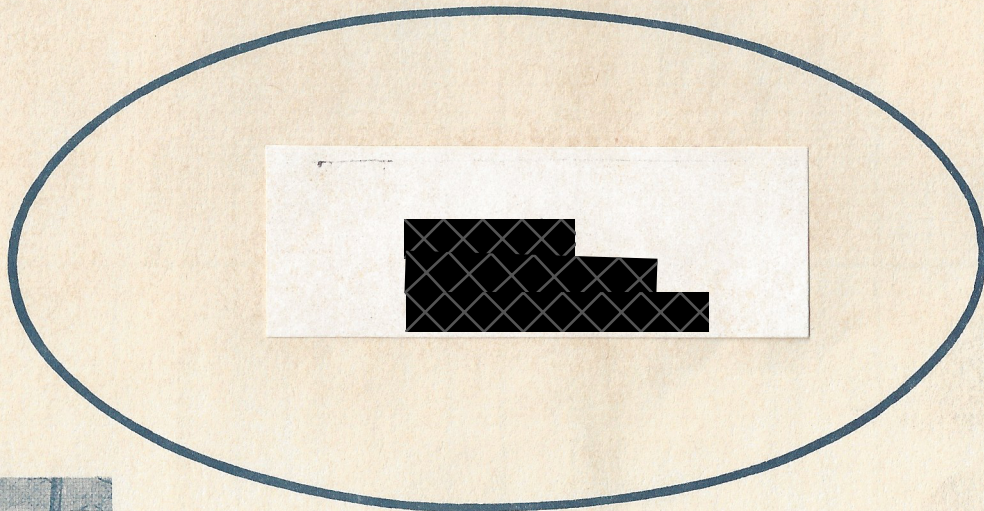

1943 Ford Jeep