

94

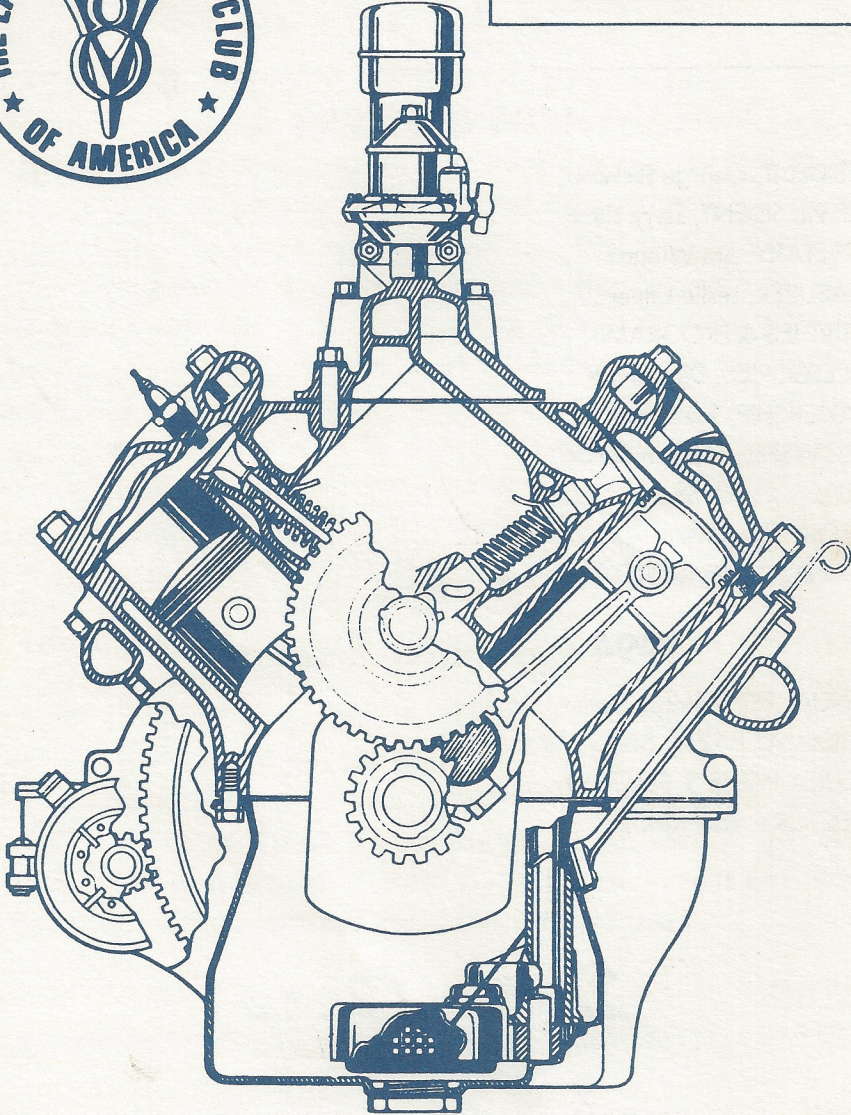

JANUARY



1994
Drive Lines

The Valley s

1994 OFFICERS

PRESIDENT, George Richards	(818) 992-4537
VICE PRESIDENT, Jerry Littner	(818) 347-1194
SECRETARY, Jim Winnett	(818) 768-4228
TREASURER, Leslie Littner	(818) 347-1194
ACTIVITIES & PROGRAMS, Chuck Shubb	(818) 882-2927
ACCESSORIES, Dick Smith	(818) 993-9538
MEMBERSHIP, Joe DiFatta	(818) 782-9883
FELLOWSHIP, Marilyn Salkin	(805) 527-4387
RAFFLES, Chuck Shubb	(818) 882-2927
EDITOR, Chuck Mair	(818) 785-9413
TECHNICAL ADVISOR, Don Dupree.....	(818) 883-2747

1994 Committee Chairmen

ANNUAL PEPPERMILL, Dudley Ochsner.....	(818) 446-1206
CHRISTMAS PARTY, Santa Claus	(800) SANTA 25
TEQUILA WILLIE'S, Bob Rose	(818) 362-4842
DIRECTORY, Paul Kirk.....	(818) 886-5467

Drive Lines

Published By

SAN FERNANDO VALLEY CHAPTER 40
of the EARLY FORD V8 CLUB OF AMERICA

P.O. Box 96
Reseda, CA 91335

COVER/ROY JONES

The Valley V8's

JANUARY 1994

PRESIDENT'S MESSAGE

As your new president the first thing I would like to say to all our members is Happy New Year. Looking on the last page of the Drive Lines and seeing all our Past Presidents makes me realize, I have some big shoes to fill. I'll do my best. Then, looking at the first page, with our past officers and new officers you find we have pretty much the same people helping us. I really would appreciate any help some of you can offer. Please give me a call. I know we have a lot of hidden talent out there.

We had a nice Christmas party and a great Santa and Mrs. Clause. There were about 58 members attending and a nice clear, crisp night. You could see all over the valley from atop the hill at the Odyssey. In the parking lot there were lots of wonderful old Fords and one little '37 coupe all dressed up for Christmas. Thank you, Jerry and Leslie.

Looking forward to this '94 to a great year for Early V8's and lots of new members. Don't forget the meeting for January has been changed to January 9. Hope to see you all there. No tours have been arranged for January.

I would like to take this opportunity to give a special THANK YOU to our past president Chuck Shubb. A job well done and much appreciated by all the members who participated in the meetings and activities last year.

George



JACKPOT

\$20.00

Could Be Yours!

(You just have to be present and wear your name badge to win.)

**PROGRAM FOR JANUARY 9, 1994 MEETING
MEET AT CONGREGATIONAL CHURCH HALL**

9659 Balboa Boulevard, Northridge

ENTER ON SUPERIOR AVENUE - PARKING LOT

7:00 P.M. Tire Kicking

7:30 P.M. General Meeting

This month we will meet on January 9th, and the program will be someone from Galpin Motors. They will be bringing a new 1994 Ford Mustang to the meeting with the new ad campaign, the commercial compares the 94 to a 64½ Mustang. A moving tradition for 30 years.

Please note... The February 6th meeting will be at the Route 66 Restaurant. 425 So. Fair Oaks Ave., Pasadena. We will probably leave from the Church Hall. Details to Follow. Phone 793-8462.

Dues are Due

If you misplaced your letter and notice
about your club renewal...

Contact membership Joe DiFatta - 782-9883.

The renewals are coming in and we want to have an
up-to-date roster and want your name in it.

**Do you know of anyone that would
like to place an ad in Drive Lines?**

Contact Pres. George Richards.

VALLEY V-8'S NEWSLETTER

TEN BRAVE PEOPLE PAID HOMAGE
TO MR. HENRY FORD - CREATOR OF
THE OLD IRON WE CHERISH & ADORE
BY DRIVING THEIR OLD CARS TO THE

VALLEY V-8 CHRISTMAS PARTY!

SPECIAL RECOGNITION TO THEM:

CHUCK & JUDY SHUBB...1931 FORD-MODEL A

GEORGE & SHIRLEY RICHARDS...1939 FORD

JERRY & LESLEY LITTNER...1937 FORD

JOHN & VIRGINIA WOLF...1940 FORD

LLOYD & DONNA PASCHAL...1953 FORD

JIM & BRIDGET WINNETT...1951 FORD

ART & LORRAINE BJORNESTAD...1953 FORD

BILL SCOTT...1936 FORD P/U

JOE & MARSHA DiFATTA...1948 FORD

LESLIE & TONI MacWILLIE...1930 FORD-MODEL A

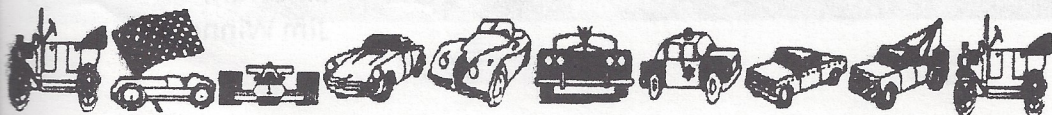

Jim Winnett's

SECRETARY'S VIEWPOINT

The 1993 Valley V-8's Christmas dinner was opened up by the 1993 President, Mr. Chuck Shubb, wishing everyone a Merry Christmas, a Happy Hanukkah and a Happy New Year.

There were 58 members and guests in attendance for the 1993 Valley V-8's dinner, which was held at the Odyssey Restaurant, with 9 Early V-8's driven.

Yours truly, said a little prayer before we ate. We had a choice of Chicken, which was good; I understand there was a beef about the beef; I did not hear anything about the fish, doesn't that sound fishy?...

After our feast, President Chuck Shubb had the honors of presenting the out going Officers with some very nice plaques.

The new officers were sworn in by the National Vice President, Mr. Howard Simpson and Lesley Littner repeated the "Oath of Office", verbatim, including the, "I, state your name," part, which got laughs and comments by Mr. Simpson. The new officers did, successfully, get sworn in and it was noted that the same people that were leaving office were the same people who were returning to office, but in a new location. With the exception of Dick Smith, who is taking over the "Accessories Department", from Lee Wright. And Virginia Wolf, who was the "Fellowship Chairperson." And Don Dupree will remain as the "Technical Advisor".

Our new, 1994, President, George Richards, promised to "Try" to get "new blood" in the offices next year.

We hope that your Holiday Season was a happy and joyous time and we hope that the new Year will be a Happy, Safe, and Productive year.

We hope you will attend all of the events and meetings this year and support the Valley V-8's and the new officers to the best of your abilities. See you on January 9, 1994 for our first meeting of 1994.

With kindest regards, I am

Sincerely,
Jim Winnett

December 2, 1988

The Valley V8's Holiday Party



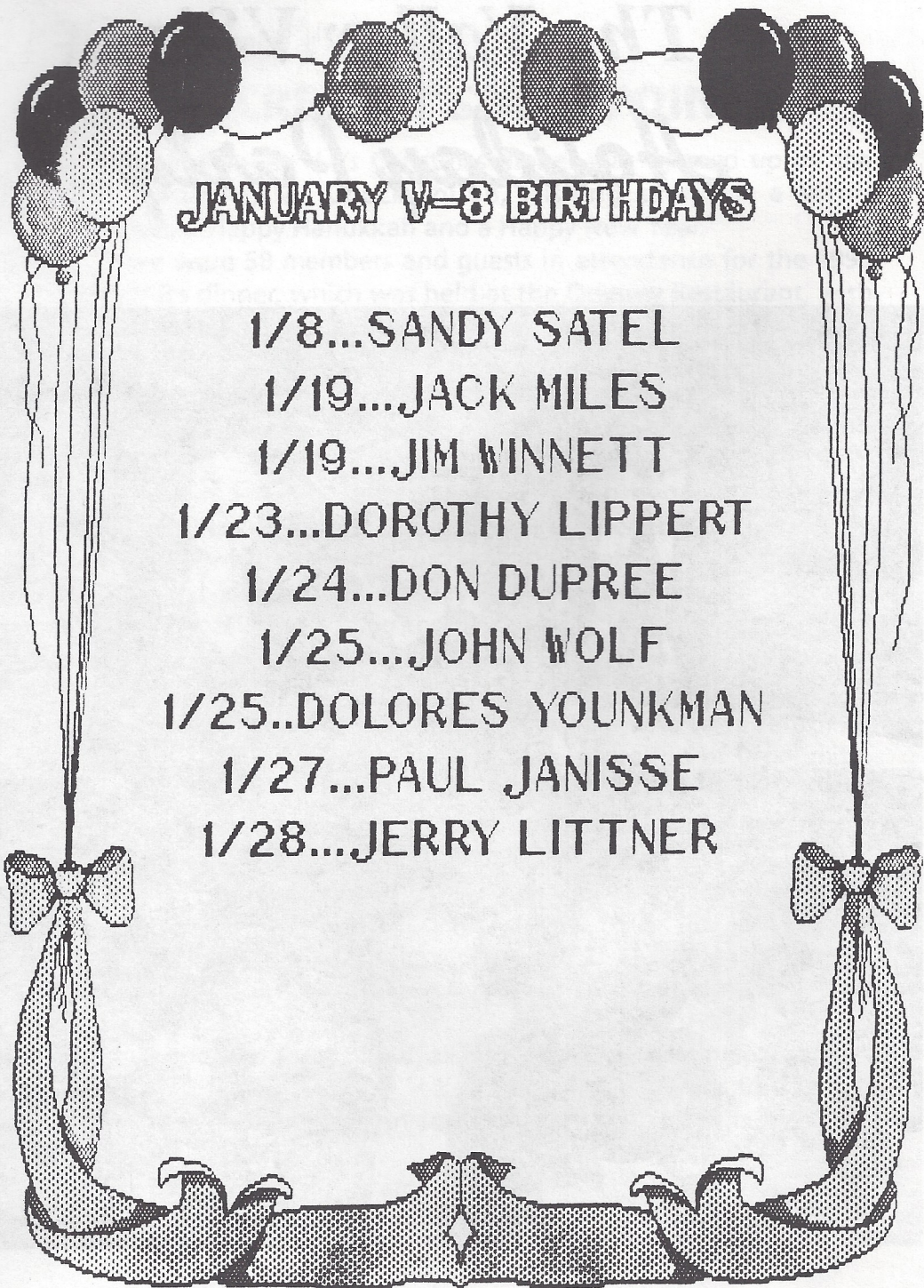

JANUARY 5-8 BIRTHDAYS

1/8...SANDY SATEL

1/19...JACK MILES

1/19...JIM WINNETT

1/23...DOROTHY LIPPERT

1/24...DON DUPREE

1/25...JOHN WOLF

1/25..DOLORES YOUNKMAN

1/27...PAUL JANISSE

1/28....JERRY LITTNER

December 8, 1993

Lesley Littner
The Valley V8's
20651 Leadwell Street
Canoga Park, California 91306

Temple
JUDEA
A Place to Belong
5429 LINDLEY AVE. TARZANA, CA 91356
818-987-2616

Dear Lesley,

Thank you and your organization so much for your very generous donation of toys to our annual toy drive.

We distribute the toys that our donated to us to the "Valley Shelter" and "Vista Del Mar". Your very generous donation will make many children very happy who would otherwise go without this holiday season.

Once again thank you.

Sincerely,

Cathryn P. Kurtz
Temple Judea Religious School

December 13, 1993

Mr. Joe DiFatta
Valley V-8 Old Ford Club
c/o DiFatta Graphics
5920 Lemona Graphics
Van Nuys, CA 91411



SAN FERNANDO VALLEY
COMMUNITY MENTAL HEALTH
CENTER, INC.

Dear Joe:

On behalf of the staff and clients at the San Fernando Valley Community Health Center, I would like to thank you and your fellow Valley V-8 members for your generous donation of one large bag of toys for our clients.

As we've discussed, our clients are on limited budgets, and the holidays are particularly difficult for them. We distributed half the toys that our adult's Adult Day Treatment program, so gift for them. The rest went to the Center's Youth Contact program, for the teens in that program to share with younger brothers and sisters.

Joe, you have certainly created a bright spot in our clients' lives. We truly appreciate your continuous support of the Center and our clients. Best wishes to you and yours for a most happy, healthy holiday season.

Sincerely,

Catherine Carson
Director of Public Relations
CC:cs

Joe -
Thank you for donating the ticket to LADS for the Random Luncheon. I know they were very appreciative!

TECH TIPS

The "No Oil" demonstration.

You have probably seen the trick performed at shows and on TV programs where an engine is treated with whatever additive is being promoted, then drained of oil, and started up and run again for hours with no oil, thus proving the effectiveness of the coating action of the product. A minor "Miracle", you say?

Briggs and Stratton, intrigued by this, repeated the test in very controlled conditions, with two identical engines, one treated with the "miracle" product, the other used standard engine oil. Guess what! Both engines performed exactly the same, to all outward appearances, and they ran them for 20 hours!! But, when they tore the engines down, they found, of course, that both were badly damaged, and the one using the special additive (a PTFE product) was damaged much more severely, especially in the cylinder bore. Apparently, the solid particles starved the smaller clearances by blocking adequate oil flow. In practically all of the reports reviewed for this article, those additives using suspended solids like PTFE caused major engine damage.

Racer's Testimonials

A frequent marketing technique in the additive business is to get a name driver to put a label on his car, and to interview him while he praises the product as being the reason for his success. It is true, that some products show a temporary increase in horsepower or economy, thus the racer, who typically hopes for 500 miles between rebuilds, has nothing to lose by accepting the "promo" money.

Most of the advertising for these products relies on anecdotal evidence. That is, letters from satisfied customers, some making truly outrageous claims for the product are solicited and shown in the ads. This is, of course, a risk free

way to get a hyped claim before the public - nothing has to be proven if it is in the form of a personal testimonial. This is just someone's personal opinion, and needs no basis in fact whatsoever.

On the other hand, there have been numerous documented, careful, scientific studies on oil additives by accredited institutions and researchers. A few examples: AVCO/LYCOMING (manufacturer of aircraft engines) "We have tried every additive we can find on the market, and they are all worthless." BRIGGS AND STRATTON "They do not appear to offer any benefits." North Dakota State University, after testing - "The theory sounds good - the only problem is that the products simply don't work."

But, you say, Slick 50 claims to have "scientific evidence" from "independent laboratories" which, unfortunately cannot be identified for "contractual reasons".

In conclusion, there is a significant body of evidence against the benefits of any oil additive other than those already present in every major brand of oil. The best thing for your engine is to change oil every 3000 miles or so, and use an oil rated at least "SF". If you feel you need a boost to the detergent action, use an oil rated "SG,CD" and stay away from the "snake oil".

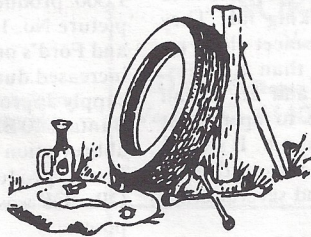

Reprinted from
TVTC Regional
Newsletter.

CHUCK SHUBB

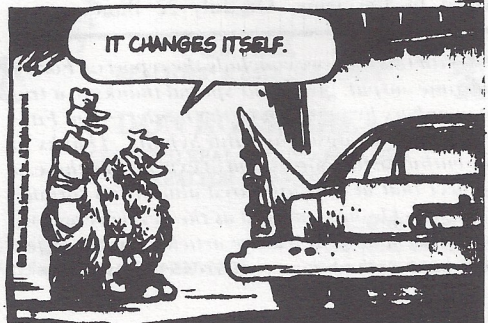

FORD'S WAR PRODUCTION *Continued*

FORD AND THE JEEP

by R. A. Hodgson

With the nation and half the world facing the prospect of war, men, materials and military vehicles were urgently needed. They say that the times produce leaders, and men such as Eisenhower, Patton and Bradley rose to meet such a challenge. It also produced an inanimate object made of steel, glass, rubber, copper and canvas, designed and created in the form of a motor vehicle the like of which the world had never seen. Almost instantly overnight a vehicle more popular than even Henry Ford's Model T won the hearts of millions of Americans and peoples of all nations. The "Jeep" was born.

Unlike the Model T it really didn't have a father, rather it was the product of many men and three major companies. The credit for designing the forerunner of the popular Jeep of World War II days belongs to Karl K. Probst of the American Bantam Car Company, their chief engineer in 1940. Probst brought together in his design the ideas of the Army Ordnance Department Technical Division, dating back to after the First World War, the Infantry Board's desire for a small car, the Marmion-Herrington Company all-wheel-drive vehicles and the Howie-Wiley machine gun carrier. Finally in June of 1940 the army set out details of the type of vehicle they were looking for. They suggested the vehicle that would meet their requirements would weigh no more than 1,200 lbs, have a wheel base of 75" or less and an overall height of 36". It should be able to operate at walking speed and travel up to 50 m.p.h. It should feature a two-speed transfer case, a front driving axle in addition to the rear axle and several other minor specifications.

On July 11, 1940 invitations to bid on seventy light reconnaissance and command cars were issued by the army. On July 22 Bantam was

awarded the contract. Working under impossible time conditions, the vehicle was designed in five days. Karl Probst built and delivered in forty-nine days the prototype, and thus the American Bantam Car Co. produced the forerunner of the World War II Jeep. Delivered to Holabird Depot at 4 p.m. September 23, 1940, American Bantam Car Company met the deadline. Watching in the wings during the test of the vehicle were Willys-Overland and Ford engineers. Both Willys-Overland and Ford submitted prototype vehicles on the 13th and 23rd of November respectively. The Willys-Overland entry was known as the Willys Quad, and the Ford product was known as the Ford GP "Pygmy" which incidentally is alive, happy and well in the Henry Ford Museum. At this time Bantam was busy supplying the seventy vehicles called for on the original contract. Bantam ¼-ton Army Truck, Serial Number 1007, is on display in the Smithsonian Institute. It is, of course, the seventh Bantam in the series built.

In the course of events and the problems created by the mishandling of the initial bids and contracts, each of the three companies was awarded a contract in November 1940 to produce 1,500 vehicles. By this time, of course, the original Army specifications had been found to be too stringent and, as a result, were relaxed somewhat. Edsel Ford drove Ford's first Jeep off the assembly line on February 28, 1941. This was the first of the 1,500 production models of the Ford GP. See picture No. 1. It is understood that both Bantam and Ford's original contract for 1,500 vehicles was increased during production. Now Bantam was to supply approximately 2,642 vehicles known as the Bantam 40 BRC, which stands for the year and the abbreviation for Bantam Reconnaissance Car. Ford's production was increased to 3,700 Ford GPs. GP was Ford abbreviation for General Purpose.

There is still a mystery and controversy surrounding the word "Jeep" and how it came to be used. One of the popular suggestions is that Jeep came from the contraction Ford GP when trying to pronounce the model designation Gee Pee which was later spelled J-E-E-P. However, there are other suggestions that have equal merit.

When the military had finally reviewed the complete initial quotas of 1,500 vehicles from each firm, they felt that they had sufficient on hand to make all the detailed comparisons and field trials that were required. The military minds seemed to be most concerned with the vehicle engines.

(With this issue we conclude the report on Ford's wartime output, giving our special thanks to a trio of members living north of the border—Jim Fitzgerald, Reg Hodgson and Bill Schultz. Thanks to the enthusiastic cooperation of experts like these, a subject that at first appeared almost too formidable to tackle, has emerged as the best coverage we have ever had on a feature article. Our heartfelt thanks to each of them for a tremendous job.)

SUPPORT OUR ADVERTISERS!

L.T. "LEE" SAWYER, INC.

Jobber

Shell Oil and Chemical Products

14117 Aetna Street, Box 369
Van Nuys, California 91408

TOM SAWYER (818) 786-8180 / (818) 785-0902

RAFFLE PRIZE DONOR

The Prudential



California Realty

13400 Ventura Blvd.
Sherman Oaks, California 91423

Bus. (818) 788-5400

Res. (818) 761-1734

Fax. (818) 784-4926

AL SPENCER
Broker Consultant



RESIDENTIAL • COMMERCIAL



KELLY ELECTRIC

ELECTRICAL CONSTRUCTION • MAINTENANCE

DAVE KELLY
ST. LIC # 657087

(818) 773-8997
(805) 255-6905

R.E. SALES

LOAN CONSULTANT

Ben F. DiFatta

MORTGAGE BROKER

LICENSED CA. DEPT. OF R.E. BROKER

23534 CANDLEWOOD WAY, WEST HILLS, CA 91307
PHONE/FAX 818-716-5583 PAGER 818-831-4567

CHRIS CONNERS' Ancient Transmission Repair

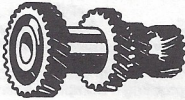

Specializing in Standard Ford Transmission Rebuilding
THREE SPEEDS-FOUR SPEEDS-OVERDRIVES

(310) 618-1586

Antique Car Radio
Repairs & Restoration

Over 50 Years
Experience

NORB FOURNIER

Van Nuys Antique Radio

13133 Weddington St.
Van Nuys, Ca. 91401

(818) 784-5836

BEV DUPRÉE

TRAVEL
TRENDS
INC.

(818) 993-5400
FAX (818) 993-3972
HOME (818) 883-2747

8902½ RESEDA BLVD.
NORTHRIDGE, CA 91324

JAMES R. GARY
&
Co. Ltd.

REALTORS® & ESTATE AGENTS

DON ROSS, CREA

CERTIFIED REAL ESTATE APPRAISER
REALTOR-ASSOCIATE®

21747 Erwin Street
Woodland Hills, CA 91367-3699

Bus: (818) 703-6100
Res: (818) 998-6594
Fax: (818) 703-1870

SUPPORT OUR ADVERTISERS!

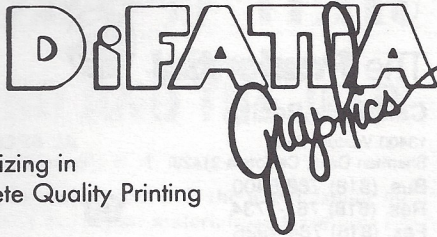

Specializing in
Complete Quality Printing

5920 LEMONA AVENUE • VAN NUYS, CA 91411
(818) 782-9883

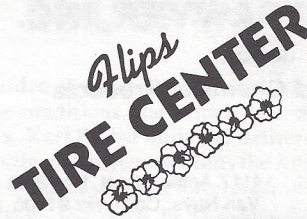

FLIP SMITH

Formerly
GLOBE TIRE

7735 Sepulveda Blvd.
Van Nuys, CA 91405
(818) 786-8686



MACHINE SHOP and BALANCING

Monday thru Friday 8 a.m. to 7 p.m.
Saturday 9 to 6 - Sunday 10 to 4

10241 Woodley (At Devonshire)

Domestic &
Foreign

Parts & Supplies



(818)

894-6441

Sepulveda, CA 91343

RAFFLE PRIZE DONOR



DISTRIBUTOR FOR:

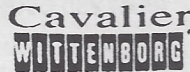

coinco • Amere
800 S. San Fernando Blvd
Burbank, California 91502

(818) 848-8703
DAVID SATEL

Older Cars
A Specialty

4 x 4's and
Motorhomes

Russell Sylvis, Inc.
Transmissions
Repaired • Rebuilt

(805) 527-4387

4657 Barnard St.
Simi Valley, CA



Roofing & Waterproofing • Complete Maintenance Service

8707-D Lindley Ave., Ste. 199, Northridge, CA 91325
Lic. #356650 **(818) 718-2313**

Auto • Homeowners

- ANTIQUE CARS -

ED HARDIN INSURANCE

Business • Life • Health • Aircraft



Call us for your Insurance needs!

(818) 363-7864

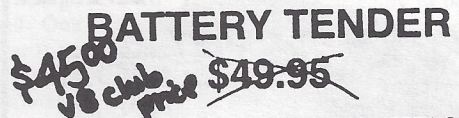

THE SAFE AND RELIABLE WAY TO KEEP YOUR
CAR BATTERY AUTOMATICALLY CHARGED UP
AND ALSO EXTEND ITS LIFE.

6 VOLT OR 12 VOLT MODELS
(\$59.50 AFTER DEC. 93)

ALLAN FRANKLIN
(818) 842-2230

PAST PRESIDENTS

JIM ROWE.....	1971
DOUG PETERSON	1972
DON DURKEE	1974
ED WARNOCK	1975
JOHN BUSK.....	1976
CHIP WERSTEIN	1977
STAN MARSRAJE.....	1978
BOB DRAKE	1979
BILL CULP.....	1979
AL SPENCER.....	1980
LARRY CAPLAN	1981
BOB ROSE	1982
DON DURKEE	1983
PAUL KIRK	1984
KENT LOWRY	1985
DAVE SANBORN.....	1986
JOHN KEMMERER.....	1987
DUDLEY OCHSNER.....	1988
JERRY JENSEN	1989
JERRY JENSEN	1990
JOE DiFATTA	1991
CHUCK SHUBB.....	1992
CHUCK SHUBB.....	1993

Meetings are held on the first Sunday of every month at 7:00 p.m.

The Valley 's

5920 LEMONA AVE., VAN NUYS, CA 91411

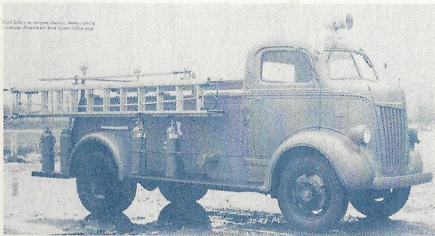
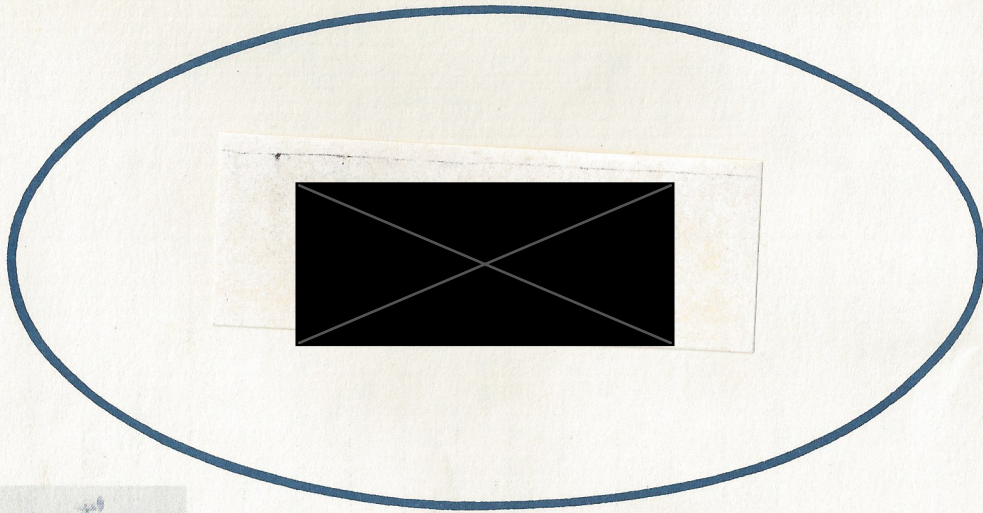

1944 Ford Cab over Fire Truck