

94

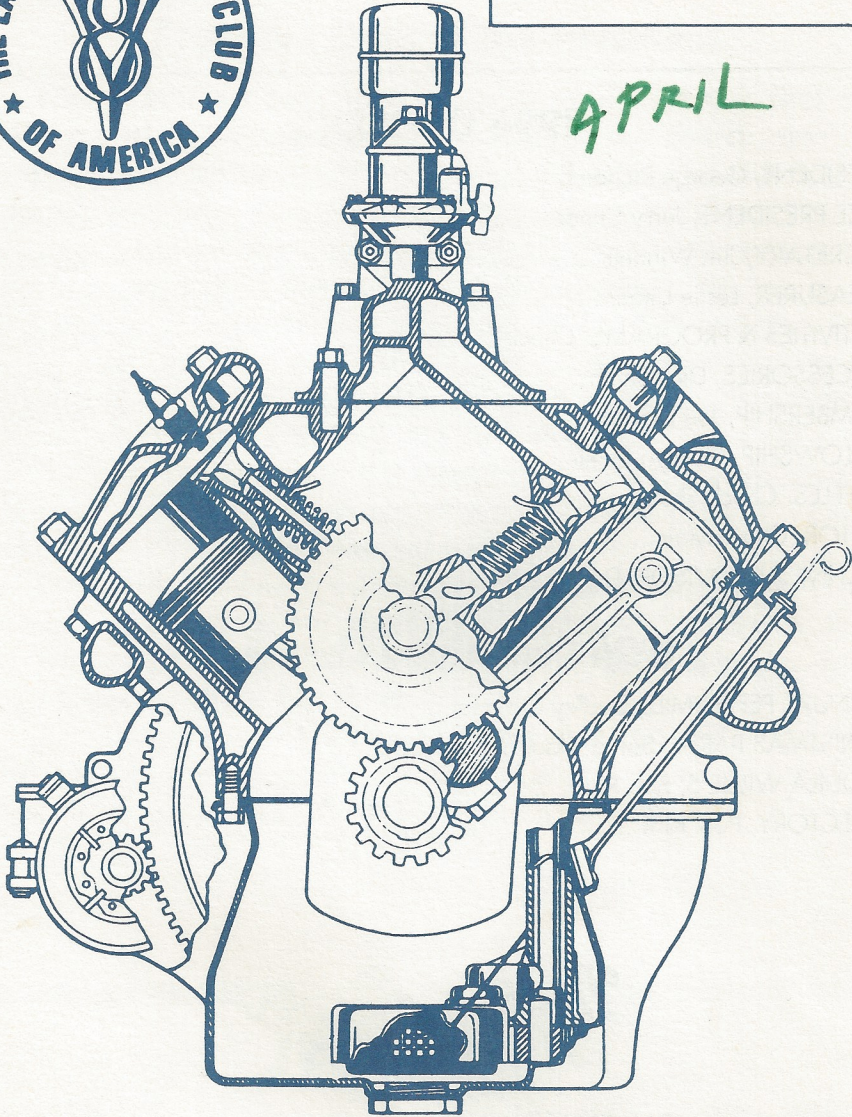

~~MARCH~~

APRIL



Drive Lines

The Valley 's

1994 OFFICERS

PRESIDENT, George Richards	(818) 992-4537
VICE PRESIDENT, Jerry Littner	(818) 347-1194
SECRETARY, Jim Winnett	(818) 768-4228
TREASURER, Leslie Littner	(818) 347-1194
ACTIVITIES & PROGRAMS, Chuck Shubb	(818) 882-2927
ACCESSORIES, Dick Smith	(818) 993-9538
MEMBERSHIP, Joe DiFatta	(818) 782-9883
FELLOWSHIP, Marilyn Salkin	(805) 527-4387
RAFFLES, Chuck Shubb	(818) 882-2927
EDITOR, Chuck Mair	(818) 785-9413
TECHNICAL ADVISOR, Don Dupree	(818) 883-2747

1994 Committee Chairmen

ANNUAL PEPPERMILL, Dudley Ochsner	(818) 446-1206
CHRISTMAS PARTY, Santa Claus	(800) SANTA 25
TEQUILA WILLIE'S, Bob Rose	(818) 362-4842
DIRECTORY, Paul Kirk	(818) 886-5467

Drive Lines

Published By
SAN FERNANDO VALLEY CHAPTER 40
of the EARLY FORD V8 CLUB OF AMERICA
P.O. Box 96
Reseda, CA 91335

COVER/ROY JONES

The Valley V8's

APRIL 1994

From the Desk of the President

March started out much more normal than our first two shaky months. We had a good turnout at our March meeting, thanks to our super members. About 60 attended the Sunday evening meeting. Our DMV speaker was a no show but Cal Beauregard saved the day. Cal's subjects are so interesting, our members were glad the speaker didn't make it. He shared his own personal experiences with Henry Ford II and the Ford Motor company. His topic this night concerned directing the motorcade for President Lyndon Johnson and the difficulties he encountered while creating the first Pope-mobile. Cal's great gift for story-telling made the evening fly by before we knew it. It was an evening you wouldn't want to miss. THANK YOU so much Cal for your much needed help.

I met with our board and we have outlined some interesting meetings for the rest of this year. Thanks to all of you that came to help that evening. Watch your calendar in the Drive Lines for these fun times.

Because of Easter Sunday, our next meeting will be on April 10th. One of our long time members Larry Caplan will speak on regulations for the 1930's and 1940's.

'Til next time.

George Richards

JACKPOT



\$20.00

Could Be Yours!

(You just have to be present and wear your name badge to win.)

**PROGRAM FOR APRIL 10, 1994
CONGREGATIONAL CHURCH HALL
9659 Balboa Boulevard, Northridge
7:00 P.M. TIRE KICKING • 7:30 P.M. MEETING
ENTER ON SUPERIOR AVENUE - PARKING LOT**

Larry Caplan will talk about two subjects of current interest.

First, he will explain the electrical system on your early V-8; the generator, the cut-out, or voltage regulator. how they work, how to test, he will have some working visual displays to show us.

Second, he will speak to us about earthquake preparedness. What happened, how we might prevent some problems if we get another 6.8. This will be a group discussion with everyone participating.

V-8 CLUB CALENDAR OF EVENTS

- APRIL 10** Regular Sunday meeting. Guest speaker, our own Larry Caplan.
- APRIL 9 & 10** Ventura V-8 Solvang tour - Call Don Durkee.
- APRIL 17** Wildflower Tour & Picnic
- APRIL 17** Fabulous Fords - \$5 entry, Knotts Berry Farm. 6a.m.-10a.m.
- MAY 1** Antique truck show, 10a.m. - 4p.m.
3044 Horace St., Riverside.
- MAY 1** Regular meeting AUCTION!
- MAY 8** CHVA Spring Car Show - Woodley Park,
Entry \$12 8a.m. - 10a.m.
- MAY 15** Tequila Willies Tour.
- MAY 22** WPE Swap Meet - Valley College.
- JUNE** Tours to Cantos Bus Museum.
- JULY** Hollywood Picture vehicles. (dates not set) 150 cars.
Tom Sparks collection. EGGE Machinery.
- AUG 7** Dupree residence annual pizza party instead of regular meeting.

Jim Winnett's

SECRETARY'S VIEWPOINT

President George Richards, opened the meeting by thanking ALL of the members (family and friends) that attended the February 20, Route 66 Restaurant event.

The "Club's" DRIVE LINES received and "HONORABLE MENTION" award for 1993, in the National Newsletter Competition...the plaque was placed in Lesley Littner's care...we may want to set up a tour to go view the plaque.

Paul Kirk was presented with a plaque for his work on our new "DIRECTORY" ...Thanks Paul.

The "NAME TAG" drawing winner was **Bill Carpenter**.

Our speaker from the DMV was not able to make it to the March meeting. So, with a 7 minute notice Cal Beauregard honored us with stories when he worked for FORD. You had to be there to enjoy the flavor of his ability to tell a story.

How did a great guy like Cal, stop working with the FORDS and go to work with Chrysler??

A special thanks goes to Patti Smith for her freshly baked Cookies...They were GREAT!

May your roads, always be safe...

With kindest regards, I am

Jim Winnett
Secretary

EARLY V-8 FORDS DRIVEN

'48 Ford, driven by Dick Smith

'51 Ford F-2 pickup, driven by Jim Winnett

CARS & PARTS FOR SALE

ITEM	Name / Phone
'67 Shelby Fastback look-a-like, factory air, disc brakes, 302 V-8...can't be told from a real Shelby...\$11,500	Ralph Hubbard (818) 792-6237
'50 Ford Hood, Gas Tank, Bumper Guards...	Jerry Jensen (818) 886-5711
Fog Lights, Genuine 1940	Jack Miles (818) 347-8617
'41 Frame	Blacky Blackwell (805) 268-0040
1947 Ford Pick Up Drivetrain Straight six, tranny, rearend. All original parts.	Steven Lemich (818) 785-6212
MUST SELL (Bill Culp's) '39 Mercury 4 door sedan. Needs complete restoration. All parts available. Best offer	Dean Schauer (805) 254-8445

CARS & PARTS WANTED

ITEM	Name / Phone
2 rear fenders '40 Coupe	John Kemmerer (818) 891-4550
Right rear fender '40	Craig Lapair (818) 893-1640
Model A for a father-in-law	Ben DiFatta (818)347-9305

APRIL V-8 BIRTHDAYS

4/03 BONNIE CARPENTER

4/07 ELAINE FRANKLIN

4/08 BUD WILLIAMS

4/08 JOE SIMON

4/11 MICHAEL MUNROE

4/12 NORM BOOTH

4/13 WALTER YOUNKMAN

4/19 JOHN POWELL

4/23 BLACKY BLACKWELL

4/27 GERRY BLACKWELL

Coastal Valley's C.H.V.A.
presents
Our Fifth Annual
SPRING CAR SHOW

Sunday, May 8th, 1994
at Woodley Park (on the grass)

Preregistration only \$12.00 until May 2nd, 1994
Day of the Show Registration \$15.00

This is not a swap meet and no "For Sale" signs can be allowed. All vehicles must be in place by 10:00 a.m. As all Southern California Car Clubs are invited, we urge early registration to be certain your car will be displayed.

Judging By People's Choice

Trophy Classes (two trophies per class)

- | | |
|--------------------|-----------------------------------|
| 1. Pre-1930 Open | 8. 1960's Closed |
| 2. Pre-1930 Closed | 9. 1970's-up Open |
| 3. 1940's Open | 10. 1970's-up Closed |
| 4. 1940's Closed | 11. Rods/Customs-All |
| 5. 1950's Open | 12. Sports Cars (2 passenger)-All |
| 6. 1950's Closed | 13. Trucks-All |
| 7. 1960's Open | 14. Best Of Show |

Hat Pins to all Entrants
Picnic Tables and Food Vendors in Park

Mail Your Entry Form & Check to :
Coastal Valley's C.H.V.A.
P.O. Box 2194
Canoga Park, CA 91306

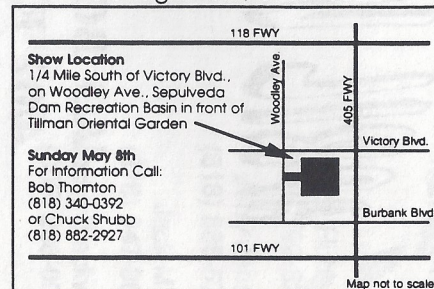

Received from member Tomy Thompson. Tomy lives in Cameron Park, CA (east of Sacramento). He says "Hello" to his fellow Ford friends. He also is recuperating from leg artery bypass surgery.

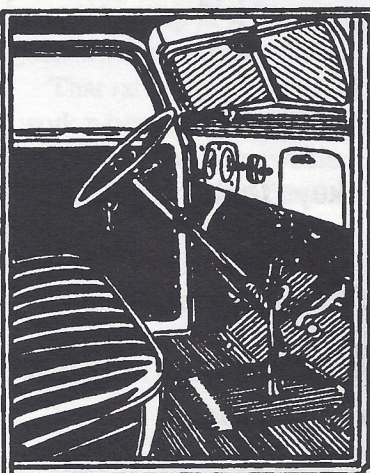

1938 FORD V-8

1-TON TRUCK

new WATERPROOF, WASHABLE UPHOLSTERY IN ROOMIER, RESTYLED CAB

\$660. f.o.b. FACTORY (PICKUP 2902 LBS.)

4 WHEELBASES —
112" PICKUP, COMMERCIAL
122" 1-TON CAPACITY
134" OR 157" 1½ TON CAPACITY

FROM 1937 TO 1940, A SMALL 60-HP ECONOMY V8 (136 c.i.d.) WAS ALSO AVAIL. (2.6" x 3.2" BORE + STROKE, 60 HP @ 3500 RPM)

STANDARD "85" V8 HAD 221 c.i.d. and 85 HP @ 3800 RPM

Circle 17 on Reader Service Card

TAP

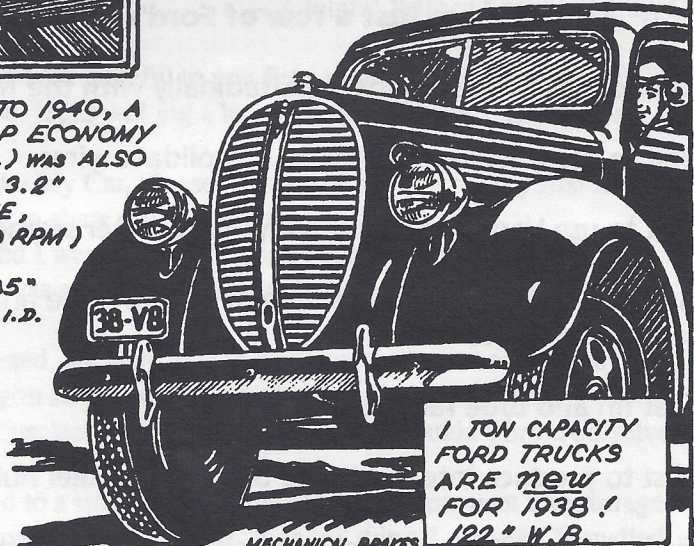

1 TON CAPACITY FORD TRUCKS ARE NEW FOR 1938! 122" W.B.

MECHANICAL BRAKES 1 TON AVAIL. AS PICKUP, PANEL, STAKE OR CHASSIS.

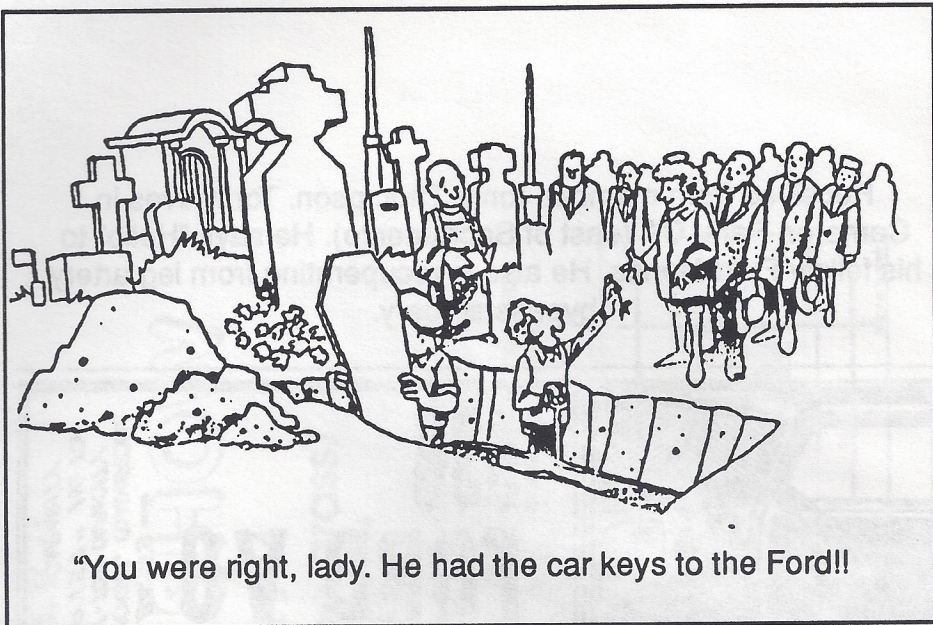

Ford's Firsts

Here are just a few of Ford's innovations:

First to mount the engine longitudinally with the frame.

First to use a wiring harness to consolidate wires.

First to use Vandium - Steel alloys for greater strength.

First to cast a multi-cylinder engine in one piece and incorporate removable heads.

First fin and tube radiator.

First to produce integral brake drum and wheel hubs.

First plastic steering wheel, replacing wood and other materials.

First to mount the spare tire in the trunk.

First to use a fingertip push button starter rather than a foot starter.

ANN LANDERS

'Brown Bomber' warms their hearts

Dear Ann Landers: Like so many others, I never thought I would write to you, but that letter from "Take My Car, Please" inspired me.

In our garage is '59 Ford pickup truck. My husband bought it 23 years ago for \$100 and a six-pack of beer. It needed a lot of repairs, but we had to have a car and couldn't afford a new one.

After a few years, we were able to retire "The Brown Bomber," but we just couldn't dump it. It takes up half the garage, but the very sight of that piece of junk warms our hearts.

That rattletrap took me to the hospital when our son was born. It got me to work when our "good" car wouldn't start. It rescued me whenever the other car broke down somewhere. Because of that beat-up old truck, my husband and I (we both came from welfare families) have made it in life.

We now own three houses, a motor home, a car and a new truck, and we have no bills. A big part of this success story is the fact that my husband never missed a day's work. The Brown Bomber never failed him.

So tell those wives who complain, Ann, to stop it. There may be a great story under that hood, one that deserves respect.

— Grateful Wife in Cathedral City, CA

Dear Wife: And I am grateful to you for a wonderfully heartwarming story. I am sure your letter will jog a lot of memories. Here's another one.

Dear Ann: "Take My Car, Please" prompted me to write my first letter to Ann Landers. I had to share my story about our first car.

When "Vern" and I were married 22 years ago, we had a 1964 Chevelle station wagon. He was so proud of that car because it was all we had at the time.

As the years passed, we were able to buy new (and more expensive) cars, but the old red wagon stayed in our garage. We had many conversations about getting rid of that "useless old eyesore", but we just couldn't bring ourselves to do it.

When we moved to a smaller place, the old red wagon went into storage. No way we could part with it. It was a "loyalty" thing. Last year, Vern died and I gave the car to our son "Kevin" is gradually fixing it up, and it will be pressed into service soon.

I know when I see that wagon again, it will help me relive our romantic courtship and those wonderful early years of our marriage.

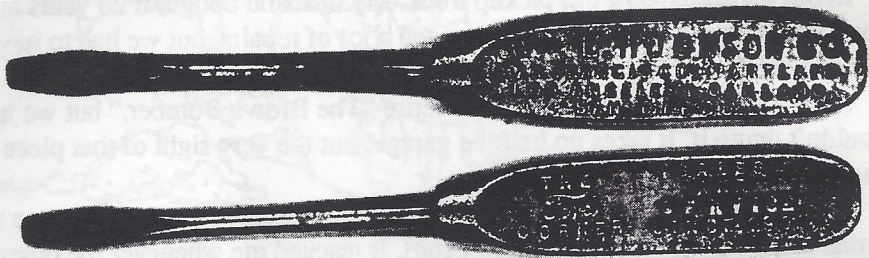

Unique Ford Screwdriver Donated

A rare and unique "give-away" screwdriver from the first Ford dealer on the West Coast has been donated by Bill "Mac" Mullan of Baldwin Park, California.

The screwdriver is from William L. "Billy" Hughson Ford, which had the distinction of being the "first authorized FORD dealer" having received it's franchise in 1902, directly from Henry Ford who wrote it out on the back of a restaurant menu.

Hughson sold Fords in San Francisco and later became Ford's "West Coast Distributor". His first sale was a 1903 Ford Model "A".

The screwdriver is stamped from a single piece of metal. The handle reads, "Wm. L. Hughson Co. - San Francisco, Portland, Los Angeles, Oakland, San Diego". The other side reads, "The FORD Corner - Sales and Service since 1902".

"Mac" Mullan is a long time Ford V8 enthusiast and for many years traveled the swap meet circuit dealing in Ford tools. In addition to the screwdriver, he also donated a "Champion" screwdriver which is also marked with Ford script and a River Rouge brass tool check.

Other donations including the screwdriver were a 1932 V8 crank handle extension and a 1933-1934 truck crank handle extension. Previously, "Mac" Mullan had donated several tools for the tire tool collection which will go on display shortly at the Towe Ford Museum in conjunction with the 1936-1939 tire display already on view.

SUPPORT OUR ADVERTISERS!

L.T. "LEE" SAWYER, INC.

Jobber

Shell Oil and Chemical Products

14117 Aetna Street, Box 369
Van Nuys, California 91408

TOM SAWYER (818) 786-8180 / (818) 785-0902

RAFFLE PRIZE DONOR

The Prudential



California Realty

13400 Ventura Blvd.
Sherman Oaks, California 91423

Bus. (818) 788-5400

Res. (818) 761-1734

Fax. (818) 784-4926

AL SPENCER
Broker Consultant



KELLY CONSTRUCTION AND ELECTRIC

LIC. # 657087
GENERAL CONTRACTORS

"Remodeling Specialists"

2558 Nicholas St.
Simi Valley, CA 93065

DAVE KELLY
Phone/Fax: (805) 520-6444

R.E. SALES

LOAN CONSULTANT

Ben F. DiFatta

MORTGAGE BROKER

LICENSED CA. DEPT. OF R.E. BROKER

23534 CANDLEWOOD WAY, WEST HILLS, CA 91307
PHONE/FAX 818-716-5583 PAGER 818-831-4567

CHRIS CONNERS' Ancient Transmission Repair



Specializing in Standard Ford Transmission Rebuilding
THREE SPEEDS-FOUR SPEEDS-OVERDRIVES
(310) 618-1586

Antique Car Radio
Repairs & Restoration

Over 50 Years
Experience

NORB FOURNIER

Van Nuys Antique Radio

13133 Weddington St.
Van Nuys, Ca. 91401

(818) 784-5836

BEV DUPRÉE

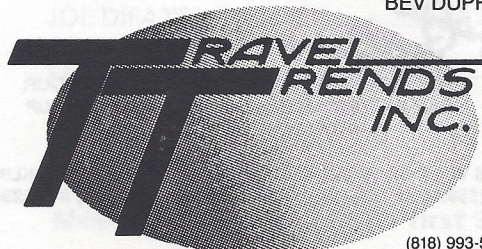

8902½ RESEDA BLVD.
NORTHRIDGE, CA 91324

(818) 993-5400
FAX (818) 993-3972
HOME (818) 883-2747

JAMES R. GARY & Co. Ltd.

REALTORS® & ESTATE AGENTS

DON ROSS, CREA

CERTIFIED REAL ESTATE APPRAISER
REALTOR-ASSOCIATE®

21747 Erwin Street
Woodland Hills, CA 91367-3699

Bus: (818) 703-6100
Res: (818) 998-6594
Fax: (818) 703-1870

SUPPORT OUR ADVERTISERS!

DiFATIA *Graphics*

Specializing in
Complete Quality Printing

5920 LEMONA AVENUE • VAN NUYS, CA 91411
(818) 782-9883

Flips TIRE CENTER

FLIP SMITH

Formerly
GLOBE TIRE

7735 Sepulveda Blvd.
Van Nuys, CA 91405
(818) 786-8686

DON'S Auto Parts

MACHINE SHOP and BALANCING

Monday thru Friday 8 a.m. to 7 p.m.
Saturday 9 to 6 - Sunday 10 to 4

10241 Woodley (At Devonshire)

Domestic &
Foreign

Parts & Supplies



(818)

894-6441

Sepulveda, CA 91343

RAFFLE PRIZE DONOR

DAVID'S VENDING

SALES AND SERVICE

DISTRIBUTOR FOR:

Cavalier
WITTENBERG

LENTRO-VENTO

BREWMATIC:
HAMILTON

COINCO • *Amoro*

800 S. San Fernando Blvd.
Burbank, California 91502

(818) 848-8703

DAVID SATEL

Older Cars
A Specialty

4 x 4's and
Motorhomes

Russell Sylvis, Inc.

Transmissions
Repaired • Rebuilt

(805) 527-4387

4657 Barnard St.
Simi Valley, CA

R.C. Smith's Roofing Solutions

Roofing & Waterproofing • Complete Maintenance Service

8707-D Lindley Ave., Ste. 199, Northridge, CA 91325
Lic. #356650 (818) 718-2313

Auto • Homeowners

- ANTIQUE CARS -

ED HARDIN INSURANCE

Business • Life • Health • Aircraft



Call us for your Insurance needs!

(818) 363-7864

BATTERY TENDER

~~\$45.00~~
~~vs club price \$49.95~~

THE SAFE AND RELIABLE WAY TO KEEP YOUR
CAR BATTERY AUTOMATICALLY CHARGED UP
AND ALSO EXTEND ITS LIFE.

6 VOLT OR 12 VOLT MODELS
(\$59.50 AFTER DEC. 93)

ALLAN FRANKLIN
(818) 842-2230

PAST PRESIDENTS

JIM ROWE.....	1971
DOUG PETERSON	1972
DON DURKEE	1974
ED WARNOCK	1975
JOHN BUSK.....	1976
CHIP WERSTEIN	1977
STAN MARSRAJE.....	1978
BOB DRAKE	1979
BILL CULP.....	1979
AL SPENCER.....	1980
LARRY CAPLAN	1981
BOB ROSE	1982
DON DURKEE	1983
PAUL KIRK	1984
KENT LOWRY	1985
DAVE SANBORN.....	1986
JOHN KEMMERER	1987
DUDLEY OCHSNER.....	1988
JERRY JENSEN	1989
JERRY JENSEN	1990
JOE DiFATTA	1991
CHUCK SHUBB.....	1992
CHUCK SHUBB.....	1993

Meetings are held on the first Sunday of every month at 7:00 p.m.

The Valley  **'s**

5920 LEMONA AVE., VAN NUYS, CA 91411

VAN NUYS
MAR 30 '94
CA
U.S. POSTAGE
52
P.D. METER
992841

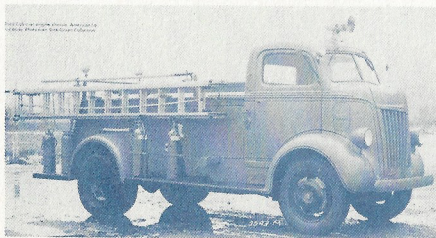
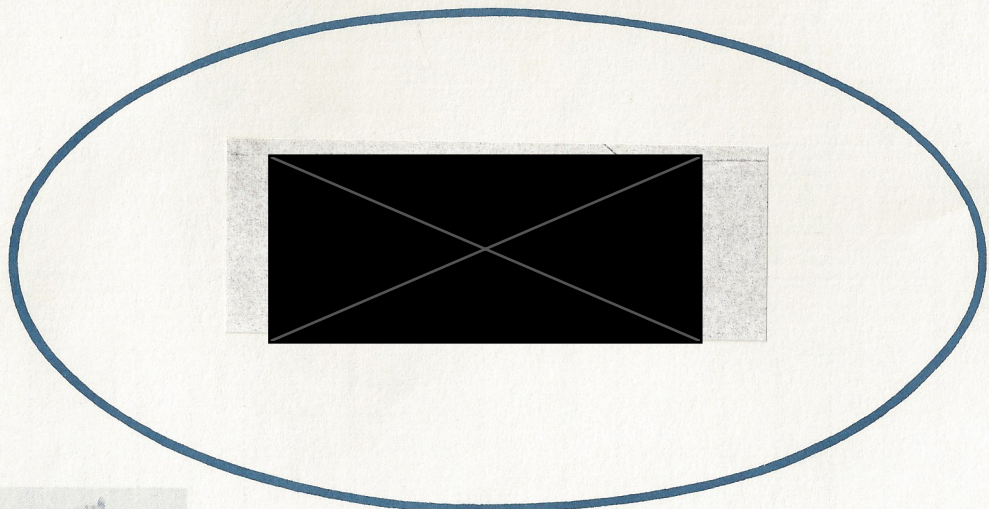

1944 Ford Cab over Fire Truck