

94

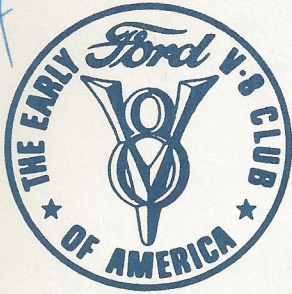

JULY

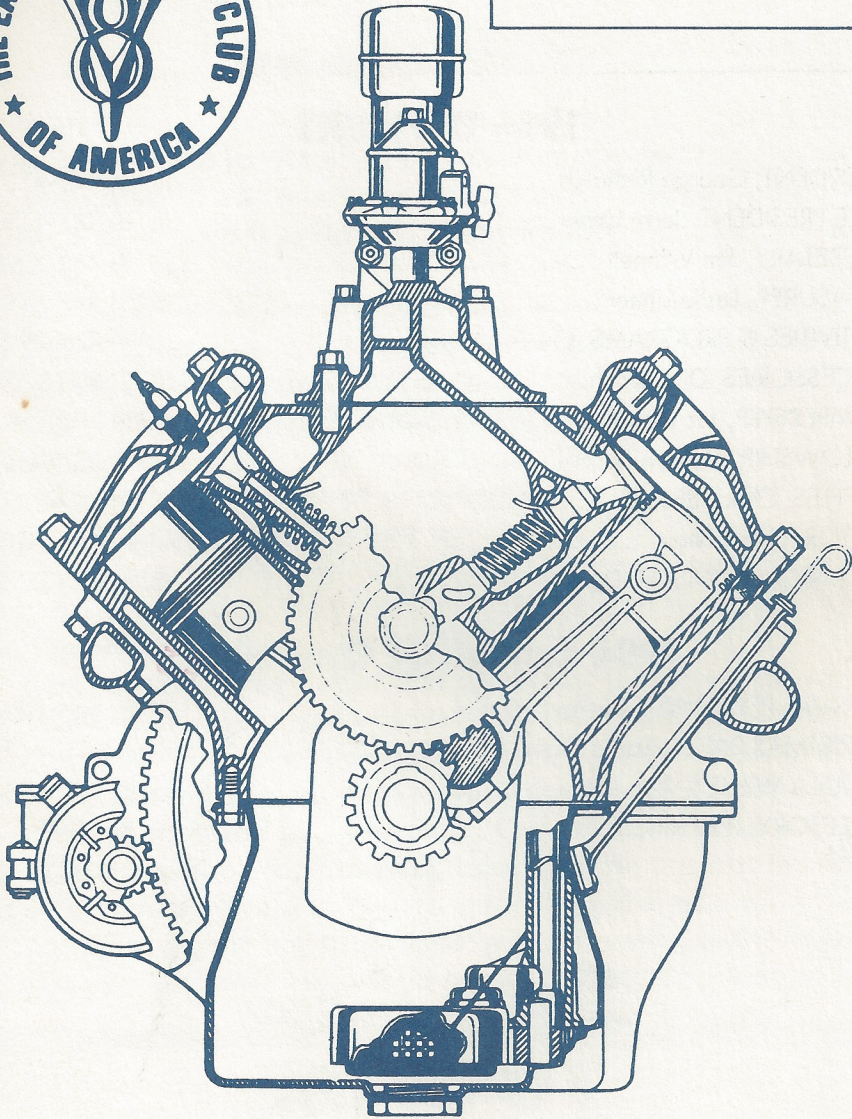

Drive Lines

The Valley 's

1994 OFFICERS

PRESIDENT, George Richards	(818) 992-4537
VICE PRESIDENT, Jerry Littner	(818) 347-1194
SECRETARY, Jim Winnett	(818) 768-4228
TREASURER, Leslie Littner	(818) 347-1194
ACTIVITIES & PROGRAMS, Chuck Shubb	(818) 882-2927
ACCESSORIES, Dick Smith	(818) 993-9538
MEMBERSHIP, Joe DiFatta	(818) 782-9883
FELLOWSHIP, Marilyn Salkin	(805) 527-4387
RAFFLES, Chuck Shubb	(818) 882-2927
EDITOR, Chuck Mair	(818) 785-9413
TECHNICAL ADVISOR, Don Dupree	(818) 883-2747

1994 Committee Chairmen

ANNUAL PEPPERMILL, Dudley Ochsner	(818) 446-1206
CHRISTMAS PARTY, Santa Claus	(800) SANTA 25
TEQUILA WILLIE'S, Bob Rose	(818) 362-4842
DIRECTORY, Paul Kirk	(818) 886-5467

Drive Lines

Published By

SAN FERNANDO VALLEY CHAPTER 40
of the EARLY FORD V8 CLUB OF AMERICA

P.O. Box 96
Reseda, CA 91335

COVER/ROY JONES

The Valley V8's

JULY 1994

President's Message

Well we are half-way through the year. It's going fast. Shirley and I want to thank all of you that sent well wishes. She is doing great. It was nice to see Bob Rose at the last meeting. We hope that Harriet is up and around soon. We wish her the very best.

Our bus museum and tour was a real BUST. Chuck Shubb, Jerry and Leslie Littner and myself waited about an hour. When no one showed up, we went home. That ends our tours for the year.

Our June meeting saw about thirty members. At that time we voted to have our July meeting on July 31. It will be our annual party at Don Dupree's residence. Due to our dwindling treasury, the membership voted to raise dues at the end of the year if we are in the red. This keeps us from having to scale back on club activities and the newsletter. Unlike the government, we can't run on credit.

Our Peppermill car show and breakfast is coming up soon. We have invited the Lincoln Continental Owners Club to join us. They seem really interested in our fine cars and showing their own. This promises to be a meet you won't want to miss. Your reservations must be in by Sept. 1. Call Dudley Ochsner (818) 446-1206. He will be glad to hear from you. He has put his time and efforts into getting us together for a good time.

Cal Beauregard we sure hope you are well on the mend. We miss you at the meetings and hope to see you back soon

George Richards

JACKPOT



\$20.00

Could Be Yours!

(You just have to be present and wear your name badge to win.)



NEXT FORD GENERAL MEETING
will be a
Social Gathering

Sunday, July 31
4:00 in the afternoon

at the home of
Don & Beverly Dupree
23222 Oxnard St.,
Woodland Hills

Plan for a fun afternoon of
relaxing, fun, games & dinner.

Jim Winnett's

SECRETARY'S VIEWPOINT

The June 5th meeting was brought to order by President, George Richards.

Chuck Shubb reminded us of the upcoming Pacific Bus Museum event on Sunday, June 12.

Bill King was the name that was drawn for the Name Badge Drawing. Bill was NOT present, so the pot rolls over to next month. The lucky Name Badge wearer will receive \$25.

Vice President, Jerry Littner, suggested that the Club do some events that would generate money for OUR Club, because our "Annual Auction" was NOT as successful as hoped. A quick motion, that was seconded, and carried, to increase our annual dues to \$25, beginning in 1995.

We were reminded that Beverly and Don Dupree are opening their home to us on JULY 31st for our August meeting...YES that is correct, our August, regular meeting, will be held on July 31 INSTEAD of August 7th. THERE WILL NOT BE A REGULAR MEETING IN THE MONTH OF AUGUST!

We had our customary break with refreshments provided by Vicki and Dennis Keene. Dennis was not able to attend the meeting, so Dennis made arrangements with Carlos Wilhelm to bring the cookies and brownies. Thank you Vicki and Dennis for the treats and thanks Carlos for bringing them so we could indulge ourselves...yum, yum!

Rather than having a guest speaker for the June meeting, we had Mr. Don Dupree graciously let us view his video tape about the Henry Ford Museum and Greenfield Village. Don recommends that if you plan a trip to Dearborn, allow at least two days to thoroughly enjoy these places, "It is well worth it".

Have a SAFE and HAPPY 4th of JULY!!

May your roads always be safe!

With kindest regards, I am

Sincerely,
Jim Winnett

EARLY V-8 FORDS DRIVEN

'36 Roadster	John and Virginia Wolf
'39 Convertible Sedan	Richard Chutuk
'39 Deluxe Tudor	Jerry Jensen
'39 Ford Convertible	George Richards
'41 Ford Coupe	Chuck Mair
'51 Ford Tudor	Les MacWillie
'51 Ford F-2 Pickup	Jim Winnett

Early vehicles driven WITHOUT flatheads:

'26 T-Roadster	Lee Wright
'27 Track T	Ken Sapper

CARS & PARTS FOR SALE

ITEM	Name / Phone
Chevy, small block, headers – \$25	Mike Munroe (818) 789-7225
'50 Ford Parts, inquire	Jerry Jensen (818) 886-5711
1972 Mustang Mach 1 – 351 Four BBL Carb, Automatic, Air Conditioning (not working), Correct 500 Mag Wheel Recent Front Buckets and Headliner, New Waterpump, Starter, Fuel Pump and Radiator – Runs Strong Gold Color with Black Trim Nasa Hood, Fold Down Rear Seat and Space Saver Spare. Some Door Dings because it Attended College Last Few Years. Tuition Bills are due again so would like to sell. Offered at \$5,750.	Dudley Ochsner (818) 446-1206 (818) 793-5104
'37 Ford Club Coupe V85, needs restoration. \$6500 OBO	Kent Fredrickson (818) 368-4111

CARS & PARTS WANTED

ITEM	Name / Phone
Hood release cover plate – 1948 Ford	Chuck Mair (818) 785-9413
'40 Ford Front Spring	Ken Sapper (818) 249-5686

Happy Father's Day



Marsha DiFatta planned a super Father's Day for hubby, Joe and the rest of the family.

Joe had a thought and pulled out his six cars out of the garage and placed them in his driveway...along with his sign saying "Happy Fathers Day...Stop and look". He had his own car show and about two dozen "Lookie Loos" stopped by and reminisced and looked over the cars. A fellow named Bob showed up on a beautiful restored Whizzer Motor Bike. On the spur of the moment, Joe met new friends and had a great father's day.

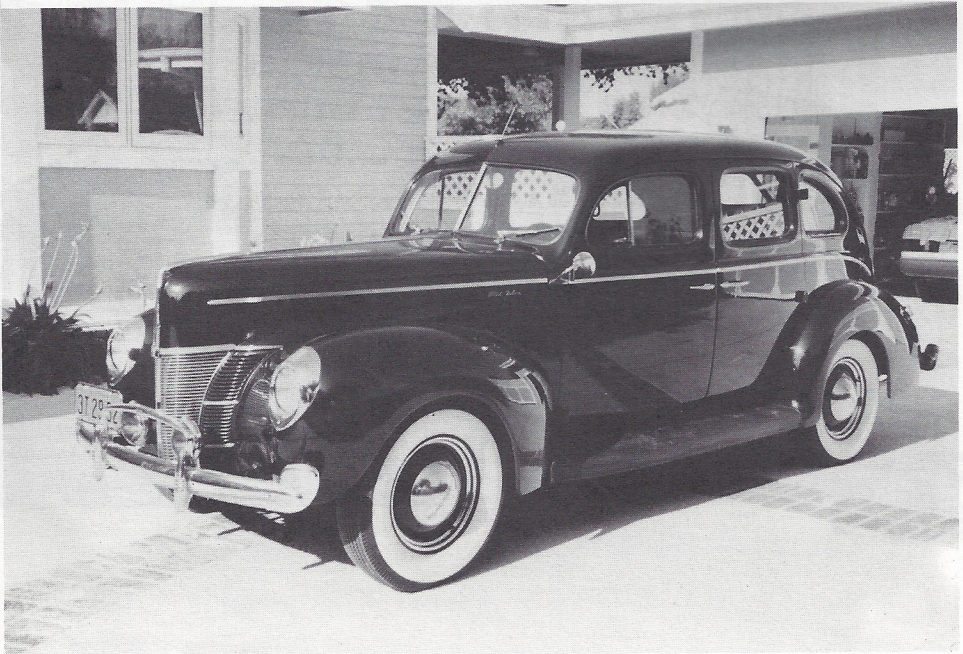



JULY 5-8 BIRTHDAYS

7/03 MARY DURKEE

7/03 TOM WELCH

7/03 BILL KING

7/08 JACKIE MONNICK

7/09 CHUCK SHUBB

7/10 GINNY COTTON

7/12 TERRI NORTON

7/12 HELEN KELEJIAN

7/15 JOE SCHUBERT

7/19 BEVERLEY DUPREE

7/22 ED HARDIN

7/23 STEVE BOSKOVICH

7/25 TERRY SMITH

7/29 HARRIETT ROSE

7/30 JOYCE BOOTH

7/31 PAT BERRY

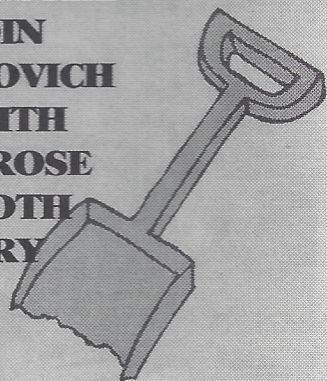
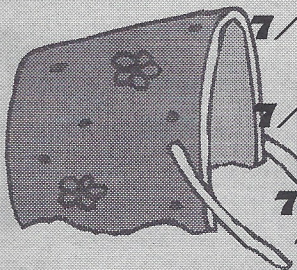

Early Ford V-8 Job of America

WEEKLY NEWS

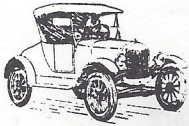

TARZANA ENCINO ROTARY CLUB

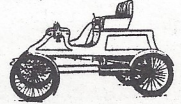

PRESENTS A

PREMIER CAR SHOW

featuring

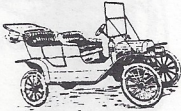

OVER 500 MODELS
OF



ANTIQUÉ CARS

CLASSIC CARS

PERFORMANCE CARS

MOTORCYCLES

CELEBRITY CARS

KIT AIRCRAFT

PLUS 40 VENDORS

SUNDAY AUGUST 14, 1994 -- 10:00 A.M to 6:00 P.M.

at

RANCHO SAN ANTONIO

21000 Plummer Street, Chatsworth, California

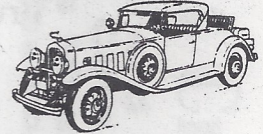
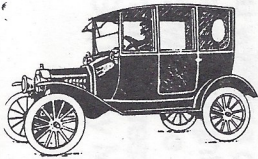

PROCEEDS TO BENEFIT

*CSUN OVIATT LIBRARY ENDOWMENT FUND
RANCHO SAN ANTONIO BOYS TOWN OF THE WEST
OTHER COMMUNITY SERVICE PROJECTS SELECTED*

AMPLE PARKING

FOOD & BEVERAGES

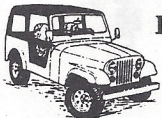

DONATION \$10.00 - Children under 12 FREE with paid Adult

For Tickets - Call

Lou Lefevre 818 996 3311
John Chesley 818 701 5533

Clare Short 818 705 3305
Joe Giardina 818 346 2455



Early Ford V-8 Club of America

Valley V-8's Host

PEPPERMILL BRUNCH 1994

795 E. Walnut St.

Pasadena, CA 91101

Baldy View

Best of Show

\$9.75 per person

Ventura

Prizes

September 11, 1994

Southern Cal

Awards

Tire Kicking 9:30 a.m.

Doors Open 10:00 a.m.

San Deigo

Fun

Brunch Served Promptly at 10:30 a.m.

RSVP by 9/6/94

Make and mail checks to :

Dudley C. Ochsner

750 East Green Street, Suite 302

Pasadena, CA 91101

(818) 793-5104

Yes I will attend the Peppermill 1994, September 11

I have enclosed my check for the amount of _____ for _____ people

Name _____ Phone _____ Regional Group _____

Tickets will be held at the door and can be picked up after 9:30

Friday Night Cruz Night

Join us for the Grand Daddy of All
Cruz Nights, 125 Cars, Great Food,
50's - 60's Music and
Good Old Fashion Fun!

All Pre - 72 Cars/Trucks Welcome



Where Ventura County
meets
Los Angeles County



LABEL'S TABLE DELI

23311 MULHOLLAND DR. WOODLAND HILLS
TEL: (818) 222-1044

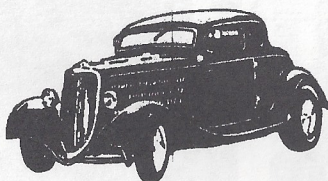

- * Our own 100 Car parking Lot,
- * Affordable menu with lots of choices,
- * Outdoor patio seating right next to your car,
- * Big picture windows in the restaurant,
- * And most important • A restaurant owner willing to work with US! (Friday Night Cruising) !!

1941 — 1942

War Wagons

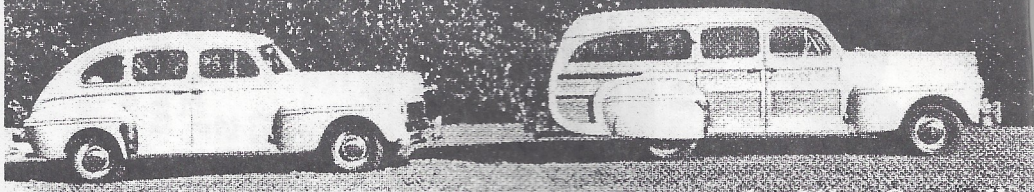

The following material is paraphrased from an article appearing in the March 1994 edition of the Highway Patrolman. Thanks to Ed Hennig who spotted the article.

The production of new vehicles was all but halted by early February 1942. This production was halted until September 1945. Some of the 1941 production was held in reserve for what was called Essential Users. These were doctors, munitions plant workers and government and Civil Defense workers. Soon this limited reserve of vehicles was exhausted.

In Milwaukee, Wisconsin a creative firm by the name of Monart Motors Company saw the need and found a solution. They retained a world famous designer/engineer by the name of Brooks Stevens to engineer the conversion of '41 and '42 vehicles into station wagons. The need was for a utility vehicle which could carry a large number of passengers and also be used for transport of items. The Fordor Sedans available were considered less desirable for the conversion than the Coupes because they were already large capacity vehicles and were extremely valuable as such. So the conversion engineered was for Ford and Mercury Coupes and Tudor Sedans. The conversion used almost entirely wood except for minimal bracing and attachment hardware. In fact the conversion yielded more raw materials that were needed for the war effort, estimated at several hundred pounds per conversion. Converted vehicles were capable of carrying 12 passengers each.

Most of the conversions were purchased by Government agencies. Although these vehicles were no longer standard production vehicles, they were quality.

Monart Motors had a 25 year reputation they needed to protect, so the product was well engineered. They carefully planned the vehicles to provide ample space, while trying to maintain the appearance of the factory design. The vehicles were extremely strong and durable. Two door sedans or coupes came in a choice of conversions with several seating arrangements possible. The first was crosswise seating for eight to nine passengers. The second featured lengthwise seating for up to 12 passengers. The third featured lengthwise seating with ambulance equipment to accommodate up to 12 passengers, or a driver and two passengers on a crosswise front seat and stretchers in the rear. The basic price for the Monart Station Wagon is estimated to be \$1953. That would indicate the conversion cost was about \$800. The vehicles did not sell in large numbers. There are no known samples known to exist today. If you have one or know of one, it's a RARITY.

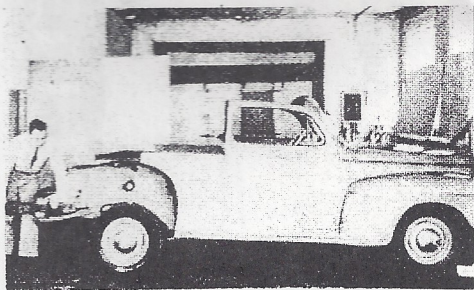

SUPPORT OUR ADVERTISERS!

BEV DUPRÉE

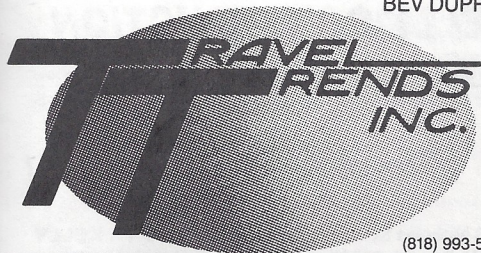

8902½ RESEDA BLVD.
NORTHRIDGE, CA 91324

(818) 993-5400
FAX (818) 993-3972
HOME (818) 883-2747

Flips
TIRE CENTER

FLIP SMITH

7735 Sepulveda Blvd.
Van Nuys, CA 91405
(818) 786-8686

Formerly
GLOBE TIRE

DON'S
Auto Parts

MACHINE SHOP and BALANCING

Monday thru Friday 8 a.m. to 7 p.m.
Saturday 9 to 6 - Sunday 10 to 4

10241 Woodley (At Devonshire)

Domestic &
Foreign

Parts & Supplies



(818)

894-6441

Sepulveda, CA 91343

RAFFLE PRIZE DONOR

JAMES R. GARY
&

Co. Ltd.
REALTORS® & ESTATE AGENTS

DON ROSS, CREA

CERTIFIED REAL ESTATE APPRAISER
REALTOR-ASSOCIATE®

21747 Erwin Street
Woodland Hills, CA 91367-3699

Bus: (818) 703-6100
Res: (818) 998-6594
Fax: (818) 703-1870

Older Cars
A Specialty

4 x 4's and
Motorhomes

Russell Sylvis, Inc.

Transmissions
Repaired • Rebuilt

4657 Barnard St.
Simi Valley, CA

(805) 527-4387

R.C. Smith's
Roofing Solutions

Roofing & Waterproofing • Complete Maintenance Service

8707-D Lindley Ave., Ste. 199, Northridge, CA 91325
Lic. #356650 (818) 718-2313

Auto • Homeowners

- ANTIQUE CARS -

ED HARDIN INSURANCE

Business • Life • Health • Aircraft



Call us for your Insurance needs!

(818) 363-7864

ALLAN FRANKLIN'S
BATTERY TENDER
\$59.99

club members
\$54.99

Charges battery up and turns itself off
automatically when it fully charged.

Takes the guess work out of battery maintenance!

(818) 842-2230

6, 8, or 12 Volt Models

SUPPORT OUR ADVERTISERS!

L.T. "LEE" SAWYER, INC.

Jobber

Shell Oil and Chemical Products

14117 Aetna Street, Box 369
Van Nuys, California 91408

TOM SAWYER (818) 786-8180 / (818) 785-0902

RAFFLE PRIZE DONOR

KELLY CONSTRUCTION

AND ELECTRIC

LIC. # 657087

GENERAL CONTRACTORS

"Remodeling Specialists"

2558 Nicholas St.
Simi Valley, CA 93065

DAVE KELLY
Phone/Fax: (805) 520-6444

Recently shown in the Hemmings magazine...

Is it really possible...2 Vega Cars with less than 50 miles on them? Do you know any stories like this for the Drivelines.

Lake-City, UT. (JULY)

COSWORTH VEGA: 1975, brand new, 22 miles, MSO. buildsheet, orig owner, garaged, \$12,000. PH: 501-945-4511, 501-753-2500, AR. (SEPT)

COSWORTH VEGA: 1975, wrong engine, 32,000 miles, solid, rust-free body, needs restoration, \$750. PH: 303-493-8474, 1-5 pm, CO. (JULY)

COSWORTH VEGA: 1975, 42 original miles, in dry storage since new, all factory stickers still on car, white interior, #411, \$10,000. PH: 708-897-6970, office hours 8-4 CDT, IL.

EVROLET, 1975

Home for Sale in West Hills

5 BR, 3 BA Home. Pool Room, Front & Rear Garages, Tile Roof, Newly Decorated Interior. \$300,000. Ben (818) 716-5583

For Rent

35 Ft. Terry Trailer for Earthquake Victims, Park on Lawn or Driveway. All Appliances \$2,000/Mo. Ben (818) 716-5583

PAST PRESIDENTS

JIM ROWE.....	1971
DOUG PETERSON	1972
DON DURKEE	1974
ED WARNOCK	1975
JOHN BUSK.....	1976
CHIP WERSTEIN	1977
STAN MARSRAJE.....	1978
BOB DRAKE	1979
BILL CULP.....	1979
AL SPENCER.....	1980
LARRY CAPLAN	1981
BOB ROSE	1982
DON DURKEE	1983
PAUL KIRK	1984
KENT LOWRY	1985
DAVE SANBORN.....	1986
JOHN KEMMERER	1987
DUDLEY OCHSNER.....	1988
JERRY JENSEN	1989
JERRY JENSEN	1990
JOE DiFATTA	1991
CHUCK SHUBB.....	1992
CHUCK SHUBB.....	1993

Meetings are held on the first Sunday of every month at 7:00 p.m.

The Valley  **'s**

5920 LEMONA AVE., VAN NUYS, CA 91411

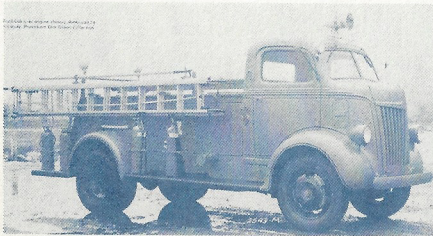
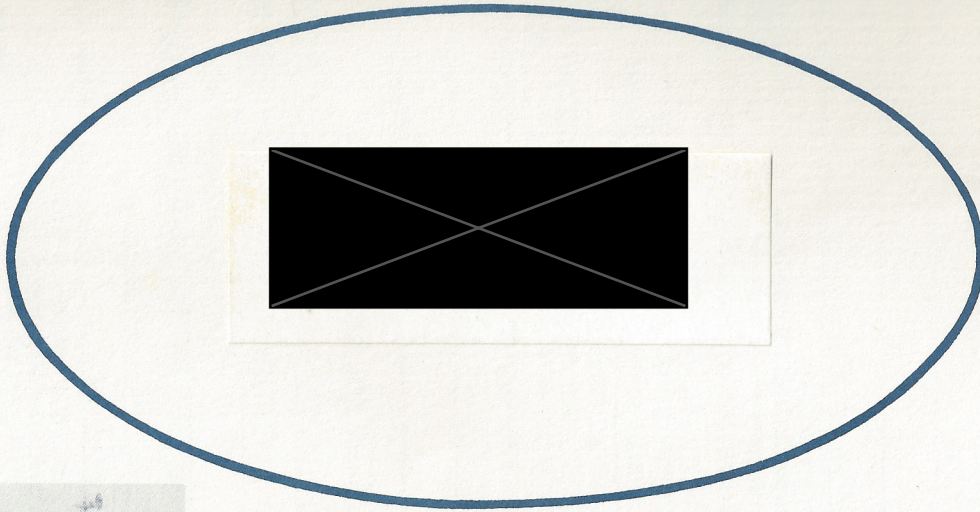
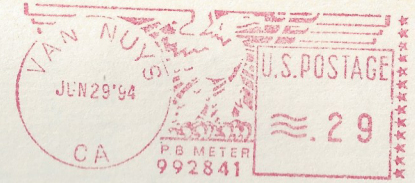

1944 Ford Cab over Fire Truck