

JANUARY

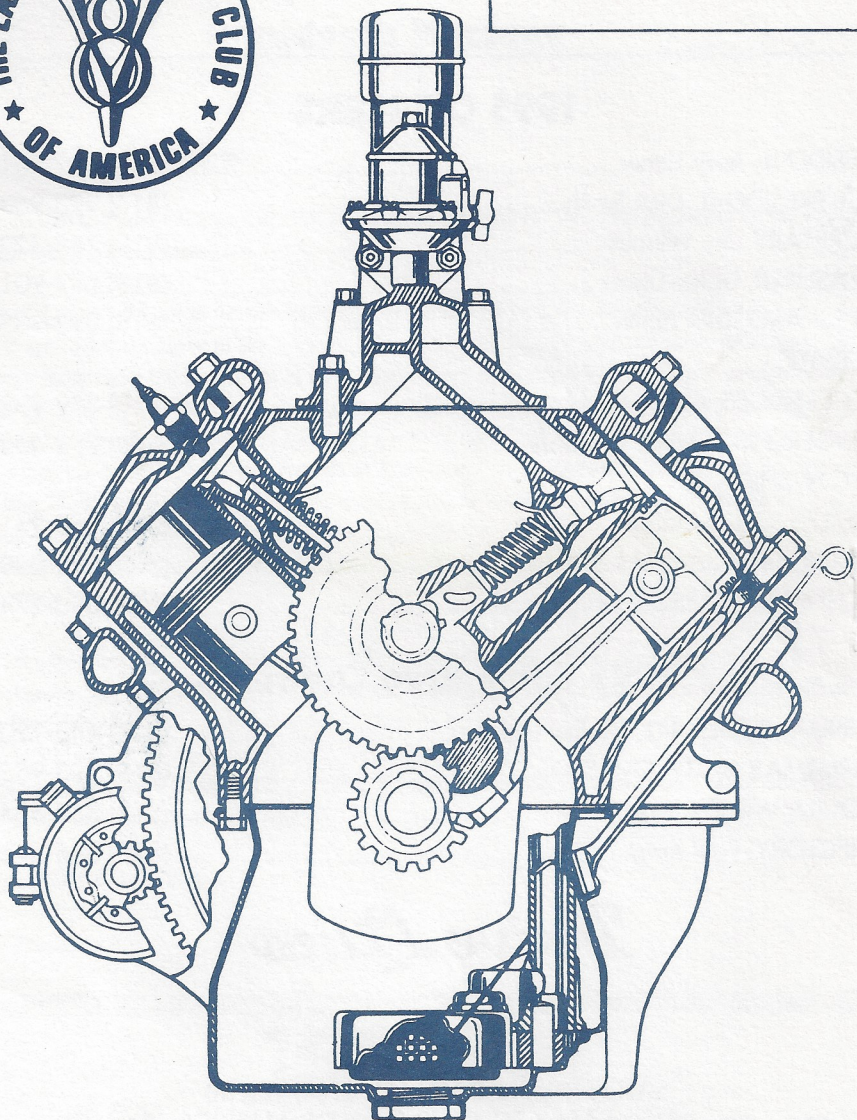

1995  
*Drive Lines*



# The Valley 's

## 1995 OFFICERS

PRESIDENT, Jerry Littner .....	(818) 597-9016
VICE PRESIDENT, Dick Smith .....	(818) 993-9538
SECRETARY, Jim Winnett .....	(818) 768-4228
TREASURER, Lesley Littner.....	(818) 597-9016
PROGRAMS, Dick Smith .....	(818) 993-9538
ACTIVITIES	
ACCESSORIES, Chuck Shubb .....	(818) 882-2927
MEMBERSHIP, George Richards.....	(818) 992-4537
FELLOWSHIP	
RAFFLES, Chuck Mair .....	(818) 785-9413
EDITOR, Miles Schofield.....	(818) 342-8881
TECHNICAL ADVISOR, Don Dupree.....	(818) 883-2747

## 1995 Committee Chairmen

ANNUAL PEPPERMILL, Dudley Ochsner.....	(818) 446-1206
CHRISTMAS PARTY, Dick Smith .....	(818) 993-9538
TEQUILA WILLIE'S, Bob Rose .....	(818) 362-4842
DIRECTORY, Paul Kirk.....	(818) 886-5467

## *Drive Lines*

Published By

SAN FERNANDO VALLEY CHAPTER 40  
of the EARLY FORD V8 CLUB OF AMERICA

P.O. Box 96  
Reseda, CA 91335

COVER/ROY JONES



# The Valley V8's

JANUARY, 1995

## President's Message

GREETINGS VALLEY V-8ers.

I would like to thank George Richards for doing a fine job in '94. Past President George is going to be a tough act to follow.

We had a great turn out at the Christmas party - about 64 people. We also had lots of fun. I would like to apologize for some of the dinners. We didn't get exactly what we were promised. See the apology letter from the restaurant in this Drive Lines. Past President Bob Rose presented the outgoing officers with their awards. Cal Beauregard presented the new officers. Lesley Littner presented achievement awards to members for their participation and dedication in club activities. The recipients were: Bob Rose - Tequila Willies tour. Cal Beauregard - for his talk on Mustangs. Virginia Wolf - for the birthday list information. Jerry Jensen - for his talk on '39 Fords. Larry Caplan - for his talk on electrical systems. David Sanborn - for his talk on '35-'36 Fords. Dudley Ochsner - for the Peppermill Brunch. Don Durkee and Dennis Keene -our auctioneers. Lee Wright - for being Santa Claus.

Our January meeting will be held on the 8TH. Our guest speaker is none other than Cal Beauregard. When Cal speaks - V-8ers listen. Good start to Dick Smith, our program officer and Vice President.

We are still looking for two good people to fill open positions - activities and fellowship. Our Club could sure use some 'new blood'.

See you January 8th. Happy New Year.

Your President Jerry.



## JACKPOT

# \$20.00

Could Be Yours!

(You just have to be present and wear your name badge to win.)



Program for January 5, 1995

**CONGREGATIONAL CHURCH HALL  
9659 BALBOA BLVD., NORTHRIDGE**

**TIRE KICKING: 7:00 P.M.**

**MEETING: 7:30 P.M.**

Our speaker will be Cal Beauregard. A great way to start our year. Bring a guest.

**DUES ARE DUE**

Contact Lesley Littner, Treasurer A.S.A.P.

Deadline will be February 1st.

Please renew your valuable membership.





*Jim Winnett's*

## SECRETARY'S VIEWPOINT

With Valley V-8ers, guests, Santa and Mrs. Claus and all of the work that Shirley and George Richards, Lesley and Jerry Littner and Judy and Chuck Shubb did, our annual Christmas Party/Installation Dinner was GREAT!!!

President George and First Lady Shirley Richards had a Christmas song "Sing-a-long". Some of the Valley V-8ers were reluctant to sing. But with a little persuading they got up and "Sang", except John Wolf. Coincidentally, John just happened to have to use the restroom, have a smoke or give someone some promised car part. So, John missed out on the singing..... darn, darn, darn! But John was present to win the table center piece, from his table, for Virginia, of course.

A turkey, ham, assorted breads and cookies (baked by an anonymous baker) were raffled. Chuck Mair was seen eating some of the cookies that Lin Kemmerer and Virginia Wolf won..... good cookies, huh Chuck?

There was a shift in position for most of our Valley V-8 Officers. With Jerry Littner moving to the President position and Dick Smith taking the Vice President position.

I hope you all have/had a safe and Happy Holiday Season and I hope that 1995 will keep you well and your roads safe.

With kindest regards, I am

Respectfully,

Jim Winnett

P.S. Thank you, Patti Smith, for the baking that you did.



## PROFILE OF A FORD ENTHUSIAST

As told to Dave Sanborn  
by Virginia Wolf

People such as John Wolf along with a combination of other factors contributed to Southern California leading the national Hot Rod movement following the Second World War. The war opened the eyes of the rest of the country to Los Angeles' many benefits: wide open spaces, near ideal weather, a young dynamic population and an embryonic industrial base. These factors created the opportunity for an automotive oriented society. John took the opportunity and became a "go fast" movement leader.

The time and place was right for John to emerge as an auto enthusiast. He was born in Hollywood, California in 1931. In 1936 he moved with his family a few miles North to Sherman Oaks in the San Fernando Valley. There he studied at Dickens Street Grammar School and Van Nuys Junior and Senior High Schools. The Valley had wide-open spaces as it grew into an urban center serving the burgeoning Los Angeles complex to the South. This setting created an environment for John's interest in the automobile.

Ford's specifically attracted John early in life since they were fast, plentiful and his family's car of choice. This relationship with Ford's has persisted to today. He built his first flathead Ford engine when he was 14. Like many innovators he learned by doing. If it didn't start or run right, he did it over and over until it did. During his school years he did a lot of street drag racing with his father's 1941 Ford Pickup.

In 1949 he received a '40 Ford Coupe as a



high school graduation present. This began in earnest his lifelong racing avocation. He first raced at San Fernando and Saugus drag strips. Then he purchased a 1936 Ford Coupe for drag racing and dry lakes speed trials. The '36 Coupe had several engines including a 249 cubic inch flathead which was raced at Bonneville attaining the top speed in its class of 135 mph in 1951.

John's career was centered around automobiles- also primarily Fords. Right out of high school he worked for Sturtevant Motor Parts for one year. Then he went to Wray Bros. Ford in Van Nuys in 1950. There he worked as a service writer until he was drafted into the Army in 1952. He trained as an airplane and engine mechanic at San Marcos Air Force Base in Texas. There he and several other California fellows started a drag racing club. One of the places they raced was on a dirt quarter-horse race track outside San Antonio.

The weekend before he was shipped overseas he took three Fords to the Saugus drag strip. Three trophies resulted: one with his '36 Ford Coupe, another with his original '40 Coupe and the third with his fathers '41 Ford pickup. In Korea he served as a helicopter mechanic and became the only person to do zieglowing and magnafluxing of helicopter and rifle parts. He was discharged as a corporal after two years service.

Upon returning he continued his Ford oriented career with Wray Bros. In due time he became service manager at his Ford dealership. In 1954 Virginia Loiselle, his High School sweetheart, and he were married. They have two daughters, Janette and Diana.

In 1961 John became interested in hydro plane racing after building a 266 cubic inch Chevrolet engine for a friend's 266 hydroplane.



His engines were so successful that between 1961 and 1967 he built numerous engines for seven different boat racing classes. In 1967 the Southern California Speedboat Club awarded John the "Keith Black" perpetual trophy for Outstanding Achievement in Engineering.

After his engine building success he decided to own a boat. So he purchased an 18 foot- 5 liter (302 cubic inch) hydro built by Ron Jones in 1969. It was a pickle fork cab over Methanol-Alcohol fuel powered boat called the "Going Thing". He belonged to the American Power Boat Association and raced all over the U. S. from Seattle to Florida and also Canada. In 1972 he broke the world's 5 liter class speed record at Parker, Arizona, which still stands at 152 MPH.

For the past 10 years he has been a volunteer mechanic on his boyhood friends unlimited hydroplane. Bob Patterson's hydro is powered by a post war Allison Airplane engine. It is raced throughout the U. S., Canada and Mexico. Over the years John built seven world record holding engines.

Wray Bros. was John's uninterrupted place of employment until it was sold in 1976. Then he was moved to Gateway Ford in Van Nuys and stayed there until 1978 when he retired. While working for Ford he earned the Ford "Silver Medallion" Award for outstanding achievement.

He is presently in partnership with Bill Brandenburg in a 27-T modified roadster powered by a 255 cubic inch turbo charged Ford, which they run at Bonneville dry lakes. To date their top speed is 229 miles per hour.

John has two 1940 Ford Coupes which he re-stored. One is maroon having a turbo charged



flathead. John fabricated and built the engine himself. The engine was installed without any cutting or damage to the inner fenders or fire wall. This coupe was featured in two national magazines: first in the April 1978 issue of Popular Hot Rodding and the second time in 1982 in the Swedish magazine Power. At the Orange County International Raceway 1978 Antique Nationals John raced the car. It turned 92 MPH in 15 seconds flat. At the same event, in its first car show, the car won the Judges Choice award.

John and Virginia are members of the Early Ford V-8 Club of America. And, they are very active in the San Fernando Regional Group. At the 1985 Valley V-8's annual Peoples Choice Car Show and Pizza Night John's maroon 1940 Ford Coupe won the first place cup.

Virginia and John are an all Ford family, also having a 1985 Thunderbird, a 1971 Mach I Mustang and a 1966 Mustang. In addition they are the original owners of a 1966 Thunderbird, a 1970 Torino and a 1970 Ranchero. Last but not least they have a recently acquired 1940 Ford Sedan which Virginia regularly drives to club functions.

John Wolf exemplifies a person who helped shape the best of automobile culture in the United States. He grew up, served his country, developed a career, helped raise a family while continuing to pursue his auto related sports and hobbies. He and Virginia continue to live a full productive post retirement life. In John's story there is a lesson for all.



## CARS & PARTS FOR SALE

---

ITEM	Name / Phone
Car Dolly, \$650.00 obo	Dick Smith (818) 368-5890
1978 3/4 Ton Van, \$1,800.00 obo	Mike Munroe (818) 789-7225
1940 Ford Sway Bar	Steve (818) 545-9344
1941 Frame, 1953 Mercury Station Wagon Parts Car	Blacky (805) 268-0040
'53 Merc Engine (new block)	John Powell (805) 647-3494
1937 85 HP engine with 36 heads, complete. Still in chassis. Listen to it run, make offer.	Richard Valleroy (310) 828-7276
1973 Lincoln Mark IV Coupe excellent condition, restored, \$3900	Jack Kelejian (805) 647-3494

## CARS & PARTS WANTED

---

ITEM	Name / Phone
1933-34 3 Lincoln	Dick (818) 360-2707
1933 Roadster	Harold Johansen (818) 784-1068
1934 2 window coupe and 1957 Ford heads for a 312 engine	Kent Lowry (818) 368-9830
'51 Ford Convertible	Bob (818) 908-1428 (805) 373-8945





10  
20  
30  
40  
50  
40  
30  
20  
10

- 1/03 JEAN WELCH**
- 1/07 LESLIE MACWILLIE**
- 1/10 BARBARA WILLIAMS**
- 1/15 BILLIE KLINE**
- 1/19 JACK MILES**
- 1/19 JIM WINNETT**
- 1/23 DOROTHY LIPPERT**
- 1/24 DON DUPREE**
- 1/25 JOHN WOLF**
- 1/25 LUANNE ROHRER**
- 1/28 JERRY LITTNER**

10  
20  
30  
40  
50  
40  
30  
20  
10

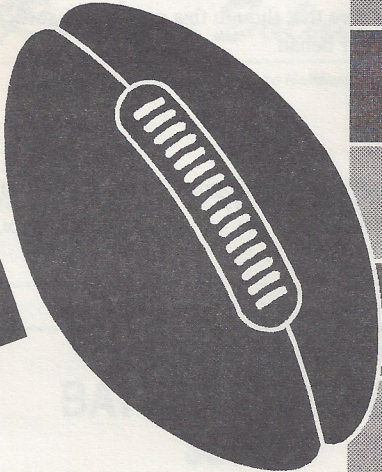
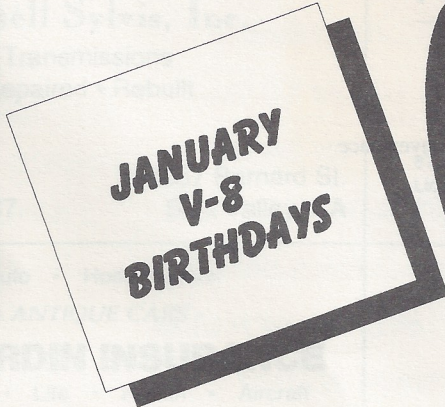



# 94<sup>TH</sup> AERO SQUADRON<sup>®</sup>

RESTAURANT AND  
BANQUET FACILITIES



16320 Raymer Avenue  
Van Nuys, California 91406

(818) 994-7437

(818) 994-7439

To the Members at the Valley Ford V-8 Club Banquet,

We at the 94th Aero Squadron Restaurant and Banquet Facilities are proud of the quality of food and service we provide for our guests. Sometimes we fail even beyond our own high expectations, as this was the case on 12/04/1994.

I regret that you and your colleagues had to endure the type of food that was served to you on this day. Though I am sure that the damage has already been done, I will assure you that it will not occur again.

The 94th Aero Squadron Restaurant is refunding your organization \$1.50 Per person on your Christmas Dinner held on the abovementioned Date as restitution towards our shortcoming. I am sure that though this may not be sufficient at this point, this will serve as a goodwill gesture on our behalf.

Once again I apologize you for your inconvenience.

Sincerely,

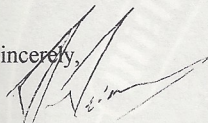

Priyantha R. Perera  
Catering Director.



# SUPPORT OUR ADVERTISERS!

BEV DUPRÉE

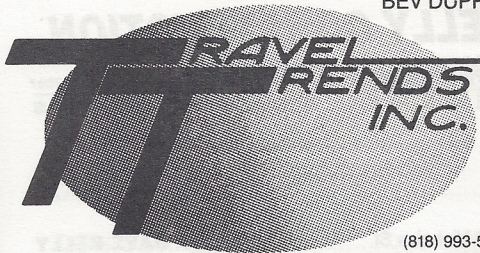

8902½ RESEDA BLVD.  
NORTHRIDGE, CA 91324

(818) 993-5400  
FAX (818) 993-3972  
HOME (818) 883-2747

*Flips*  
**TIRE CENTER**

FLIP SMITH

7735 Sepulveda Blvd.  
Van Nuys, CA 91405  
(818) 786-8686

**DON'S**  
Auto Parts

MACHINE SHOP and BALANCING

Monday thru Friday 8 a.m. to 7 p.m.  
Saturday 9 to 6 - Sunday 10 to 4

10241 Woodley (At Devonshire)

Domestic &  
Foreign  
Parts & Supplies



(818)  
**894-6441**

Sepulveda, CA 91343

*RAFFLE PRIZE DONOR*

Older Cars  
A Specialty

4 x 4's and  
Motorhomes

Russell Sylvis, Inc.  
Transmissions  
Repaired • Rebuilt

4657 Barnard St.  
Simi Valley, CA

(805) 527-4387

*R.C. Smith's*  
**Roofing Solutions**

Roofing & Waterproofing • Complete Maintenance Service

8707-D Lindley Ave., Ste. 199, Northridge, CA 91325  
Lic. #356650 (818) 718-2313

Auto • Homeowners  
- ANTIQUE CARS -

**ED HARDIN INSURANCE**

Business • Life • Health • Aircraft



Call us for your Insurance needs!

**(818) 363-7864**

ALLAN FRANKLIN'S  
**BATTERY TENDER**  
**\$59.99**

*club members  
\$54.99*

Charges battery up and *turns itself off*  
automatically when it fully charged.

Takes the guess work out of battery maintenance!

(818) 842-2230

6, 8, or 12 Volt Models



# **SUPPORT OUR ADVERTISERS!**

## **L.T. "LEE" SAWYER, INC.**

Jobber

Shell Oil and Chemical Products

14117 Aetna Street, Box 369  
Van Nuys, California 91408

TOM SAWYER (818) 786-8180 / (818) 785-0902

*RAFFLE PRIZE DONOR*

## **KELLY CONSTRUCTION AND ELECTRIC**

U.C. # 657087

**GENERAL CONTRACTORS**

*"Remodeling Specialists"*

2558 Nicholas St.  
Simi Valley, CA 93065

**DAVE KELLY**  
Phone/Fax: **(805) 520-6444**



## **VALLEY V-8 CLUB OFFICERS 1995**

**PRESIDENT...JERRY LITNER**

**VICE-PRESIDENT...DICK SMITH**

**SECRETARY...JIM WINNETT**

**TREASURER...LESLEY LITNER**

**PROGRAMS...DICK SMITH**

**ACTIVITIES...?????????**

**ACCESSORIES...CHUCK SHUBB**

**MEMBERSHIP...GEORGE RICHARDS**

**FELLOWSHIP...?????????**

**RAFFLES...CHUCK MAIR**

**EDITOR...MILES SCHOFIELD**

**TECHNICAL ADVISOR...DON DUPREE**



## PAST PRESIDENTS

JIM ROWE.....	1971
DOUG PETERSON .....	1972
DON DURKEE .....	1974
ED WARNOCK .....	1975
JOHN BUSK.....	1976
CHIP WERSTEIN .....	1977
STAN MARSRAJE.....	1978
BOB DRAKE .....	1979
BILL CULP.....	1979
AL SPENCER.....	1980
LARRY CAPLAN .....	1981
BOB ROSE .....	1982
DON DURKEE .....	1983
PAUL KIRK .....	1984
KENT LOWRY .....	1985
DAVE SANBORN.....	1986
JOHN KEMMERER .....	1987
DUDLEY OCHSNER.....	1988
JERRY JENSEN .....	1989
JERRY JENSEN .....	1990
JOE DiFATTA .....	1991
CHUCK SHUBB.....	1992
CHUCK SHUBB.....	1993
GEORGE RICHARDS .....	1994

**Meetings are held on the first Sunday of every month at 7:00 p.m.**



**The Valley**  **'s**

5051 BLACKPOOL AVE., AGOURA, CA 91301

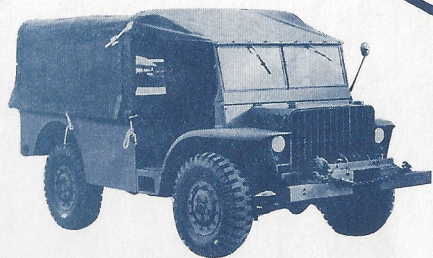
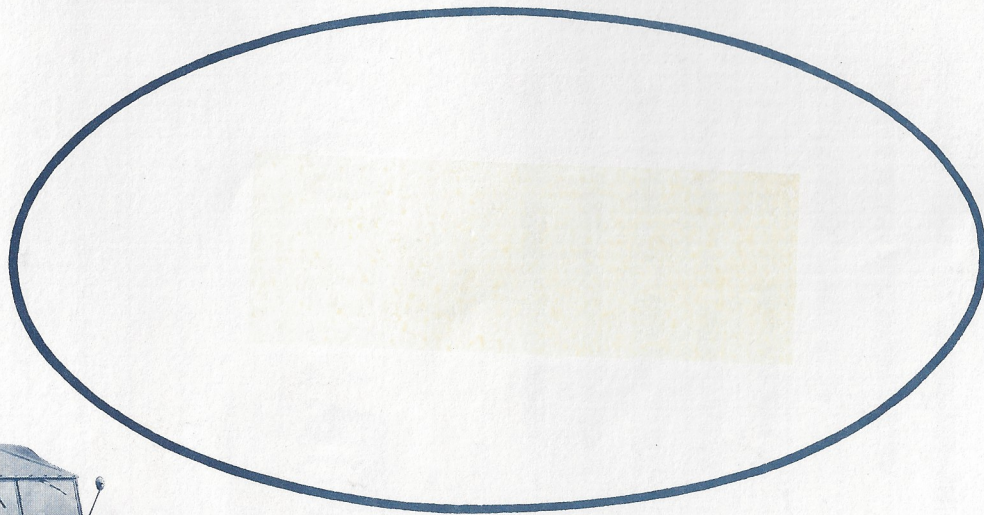
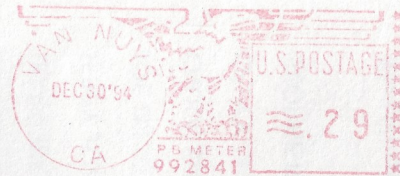

**1945 Ford Cargo Truck**