

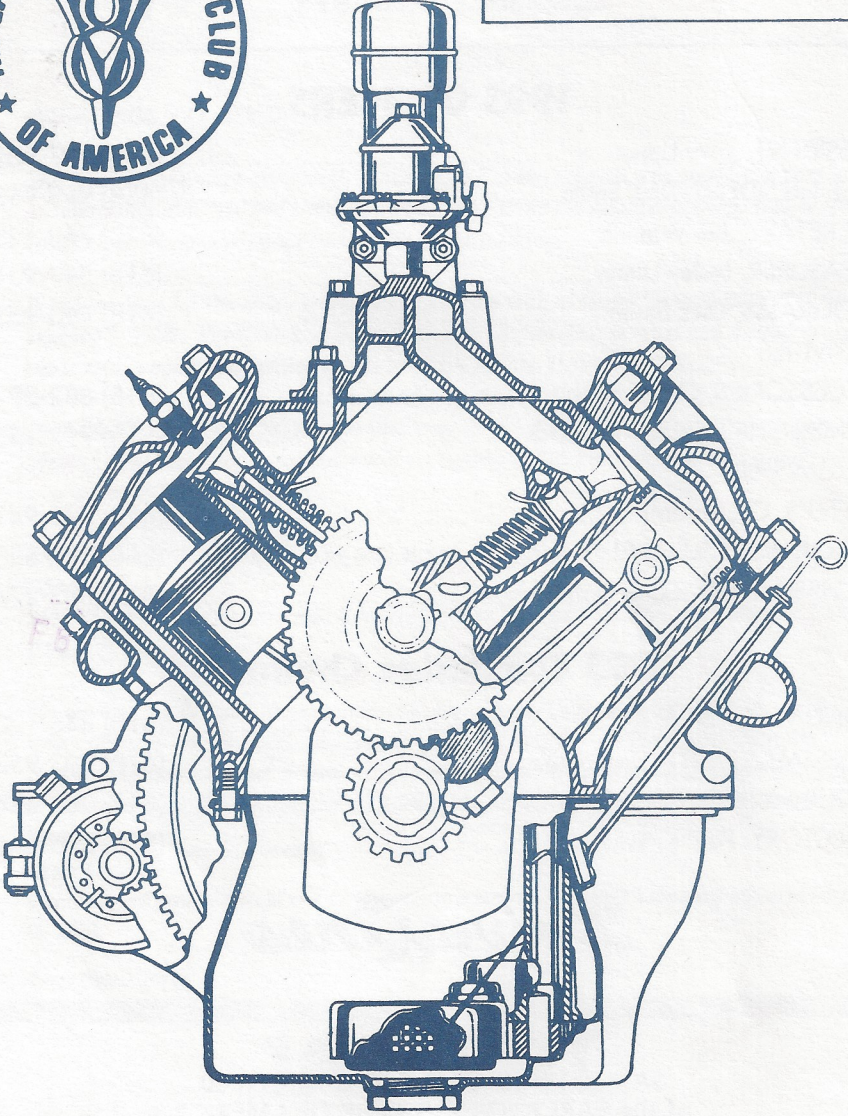

FEBRUARY



Drive Lines

The Valley s

1995 OFFICERS

PRESIDENT, Jerry Littner	(818) 597-9016
VICE PRESIDENT, Dick Smith	(818) 993-9538
SECRETARY, Jim Winnett	(818) 768-4228
TREASURER, Lesley Littner.....	(818) 597-9016
PROGRAMS, Dick Smith	(818) 993-9538
ACTIVITIES	
ACCESSORIES, Chuck Shubb	(818) 882-2927
MEMBERSHIP, George Richards.....	(818) 992-4537
FELLOWSHIP	
RAFFLES, Chuck Mair	(818) 785-9413
EDITOR, Miles Schofield.....	(818) 342-8881
TECHNICAL ADVISOR, Don Dupree.....	(818) 883-2747

1995 Committee Chairmen

ANNUAL PEPPERMILL, Dudley Ochsner.....	(818) 446-1206
CHRISTMAS PARTY, Dick Smith	(818) 993-9538
TEQUILA WILLIE'S, Bob Rose	(818) 362-4842
DIRECTORY, Paul Kirk.....	(818) 886-5467

Drive Lines

Published By

SAN FERNANDO VALLEY CHAPTER 40
of the EARLY FORD V8 CLUB OF AMERICA

P.O. Box 96
Reseda, CA 91335

COVER/ROY JONES

The Valley V8's

FEBRUARY, 1995

President's Message

GREETINGS VALLEY V-8ers:

The first meeting went quite well. Once again Cal Beauregard was great. Cal sure leads an interesting life. We had a real great turn-out. Even the rain did not stop fellow V-8er, Don Dupree from driving his 1946 oldie to the meeting.

A sad moment for the club - Dorothy Lippert, the wife of Grant Lippert, passed away January 1, 1995. The Club honored her memory by sending flowers and a condolence card. Our deepest sympathies go out to Grant and the family.

1995 DUES ARE DUE NOW ! Be sure your dues are paid up or you will not receive the March Drive Lines and your name will not appear in the 1995 membership roster. As of now we have 54 paid members.

The February 5th meeting will be held at a new location: GLENDALE FEDERAL SAVINGS
21821 Devonshire, Chatsworth, CA. 91311. Tire kicking 7:00 P.M. - Meeting at 7:30 P.M.

We are looking forward to some interesting events and meetings for 1995. Be on the look-out for: Bingo & Pizza meeting, Dupree Bar-B-Q & Past Presidents Day, the Bothwell Collection tour, Wildflower Tour, Tequila Willie's Brunch, Peppermill Brunch, a Technical Shop at Don Dupree's featuring the Brake System and another featuring Carburetors.

Come on out and join us at our new meeting location.. See you February 5th - driving an OLDIE.

Your Pres.- Jerry



JACKPOT

\$20.00

Could Be Yours!

(You just have to be present and wear your name badge to win.)

Program for February 5, 1995

GLENDALE FEDERAL SAVINGS

21821 DEVONSHIRE, CHATSWORTH

TIRE KICKING 7:00 P.M.

MEETING: 7:30 P.M.

STEERING FOR YOU AND ME, WITH "PROFESSOR" DON DUPREE.

Are you wandering through life?

Are your trips liable to end up in the ditch?

Do you aim your early Ford instead of steering it?

If you are tired of not knowing which way you are going, come to the February meeting and let "Professor" Don Dupree tell you how to get there in a straight line. Don will cover adjustments, problems, repairs, and all there is to know about your steering gearbox. Don, you know, has one of the few '34's equipped with '35 steering. If you think about it, '34 and earlier V-8's came out with the drag link running lengthwise. '35's have the drag link running across the vehicle, which is known as "cross" steering. They were much easier to steer, especially during parking, than the earlier models. Putting the '35 setup into a '34 or earlier chassis is not easy, but Don can tell us how it's done. He will bring plenty of hard parts for you to look at and drool over.

COME TO THE MEETING, AND DON WILL STEER YOU STRAIGHT

SECRETARY'S VIEWPOINT

The first meeting for 1995 opened by our NEW President Jerry Littner.....he said he was nervous...I didn't notice. And now there are only eleven to go.

President Jerry Littner reminded us that our membership dues are due and he would like to have them ALL in by the FIRST of February 1995. Our First Lady, Lesley Littner, also our Treasurer, said that an envelope was provided in December 1994 Drive Lines. You may use that envelope or another of your choosing....just send your dues in.....PLEASE!!!

President Littner handed out the plaques to the Officers with their names spelled correctly...and they are; Joe DiFatta, Don Dupree, Chuck Mair, Miles Schofield and Jim Winnett.

Our guest speaker for the January 1995 meeting was our own Valley V-8er, Cal Beauregard. There is no way that I could relay the story with the same flavor that Mr. Beauregard does. You simply have to be there to appreciate him stories and the way that he tells them. But, if you want a good laugh, ask Cal to tell you about the "Spare Tire" in the Ranchero story....

Just for your information, on the inside cover of the Drive Lines lists all of the Officers and their telephone numbers, mine has changed...it is (805)522-3377, it might be easier to remember it this way; (805)52BEERS.

With kindest regards, I am

Respectfully,

Jim Winnett

CARS & PARTS FOR SALE

'39 Ford - Windshield, Windshield wiper motor, Standard bumper guards, Windshield open mechanism, Standard grill trim, Body and hood trim, Trunk handle base and Trunk latch assembly.

Jerry Jensen (818)886-5711

Fresh 81A short block - \$1800.00

Fresh 59-A short block - \$1800.00

Fresh 8BA short block - \$1700.00

They all have NEW components, you have a choice of camshafts and all have 4 inch strokes.

Jack Miles (818)347-8617

EARLY V-8, FORD, DRIVEN

A 1946 Ford pickup driven by DON DUPREE was the only Early V-8 Ford that braved the rain.

One member said, "Too much rain".

1941 Super Deluxe Coupe Sedan, many new parts
1932 Ford Roadster Hi-boy, Factory body,
new 59A full race engine,
Spare 21 stud complete engine.
Will sell or trade for closed car.
Also many flathead Ford parts for sale.

Jay Fortman
619-377-4686

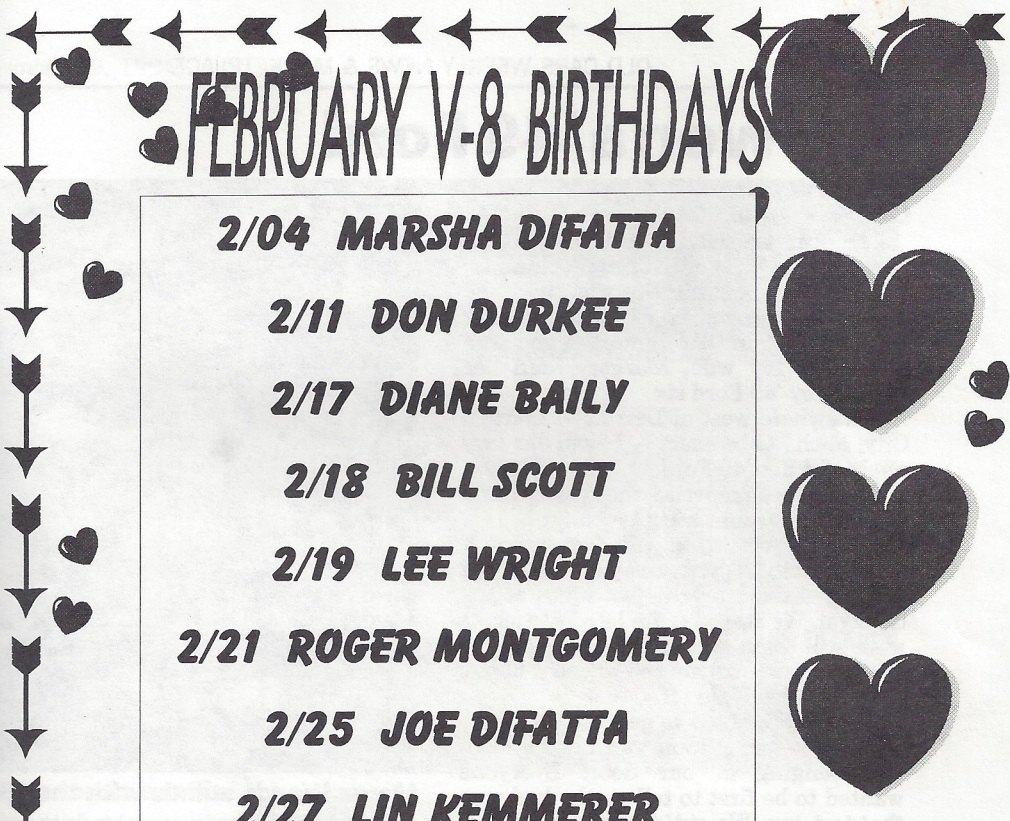

FEBRUARY V-8 BIRTHDAYS

2/04 MARSHA DIFATTA

2/11 DON DURKEE

2/17 DIANE BAILY

2/18 BILL SCOTT

2/19 LEE WRIGHT

2/21 ROGER MONTGOMERY

2/25 JOE DIFATTA

2/27 LIN KEMMERER



She won a '49 Ford

By W.D. Woods
Casselberry, Fla.

Last year, I read an article by *Old Cars'* "Somewhere West of Laramie" columnist Tim Howley about his love affair with the '49 Ford. This inspired me to dig into our family album until I found the enclosed picture of my wife, Margery, and her Birch Grey '49 Ford six.

Somewhere west of Detroit — Garden City, Mich., to be exact — began our love affair and her '49 Ford.

We had been married about a year and Marge had bought a book of tickets on a new Ford at something like five for a dollar. It was to be given away by a group of the city fathers on the last night of the carnival. We stayed quite late but tickets were still coming in and she had to go to work the next morning so we went home. I had just been laid off.

As we were about to get into bed there were cries and yelping out on the lawn and banging at our door. Everyone wanted to be first to tell us she had won the new car. We got dressed and drove down to the Ford garage and a man was just putting it inside for the night. I asked him who had won the car and he said "a woman named Woods."

As this is over 40 years ago I don't recall all the details but when we went to pick up her "free" car we found we owed quite a good sum of money. It seems that the local realtor wanted to give away a Cadillac but the city fathers felt with times the way they were a Ford was more in line. This angered the realtor who usually sold as many tickets as everyone else put together, so he refused to sell any tickets that year.

Besides the usual charges, tax, license, and title, we found that we also had to pay for the radio and heater. Apparently this drawing had cost the local city fathers their collective shirt. At the time this was



Marge Woods stands with the 1949 Ford she won in a raffle.

quite a sum for us to come up with unexpectedly.

Later we took a vacation and drove to New Brunswick, Canada. On our return trip back into the states we were on the Connecticut Turnpike (or maybe it was called the "Parkway"). At a toll booth a police car screamed past us and blocked the bridge. I told my wife we had better stay put because they were sure after someone. It was us!

I was told to follow the police car back to the police station in the nearest small town. The police car went into a drive and drove around back, I parked out front and we walked in. That was my second mistake, I was suppose to drive around back so they could check out our "souped-up" motor. I was given a choice after being taken to the basement where the jail was. We could stay in town until the next time

court was held (court was on Wednesday and this as Thursday), or they would lock me up to be sure we didn't leave. I told the officer in charge that I didn't have much choice as I was due back in camp on Saturday and if I wasn't I'd be locked up when I got back. That was one time being in the National Guard paid off. We were leaving on our two-week maneuvers.

During this time someone had gone out front and opened the hood to find a standard six-cylinder motor. I was told that the unmodified engine was all that saved me and for my first transgression of the law I was given a warning ticket for 98 mph and told a copy would be sent to my local police in Michigan. I believe I still have the onion skin copy someplace.

Later, I got a job in a factory in Detroit right behind the factory where my wife worked in the office. We would ride to-

gether when possible but one night I had to work several hours overtime so she got a ride home.

It has been snowing hard all afternoon and when I came out around nine a.m. the bright lights of the parking area showed only a line of bumpers of the cars backed against a fence. I thought that if I ever saw a commercial for a car starting in adverse conditions this would be it.

The snow was light and fluffy. As it was very cold, I was easily able to dig a path with my hands to the car door and get in. When I turned the key the Ford's motor started instantly and I pulled right out of the drift.

Maybe on our 49th anniversary we will find another Birch Grey 1949 Ford six and celebrate our love affair. If such a car is available at that time I am sure I will find it in your classified ad section

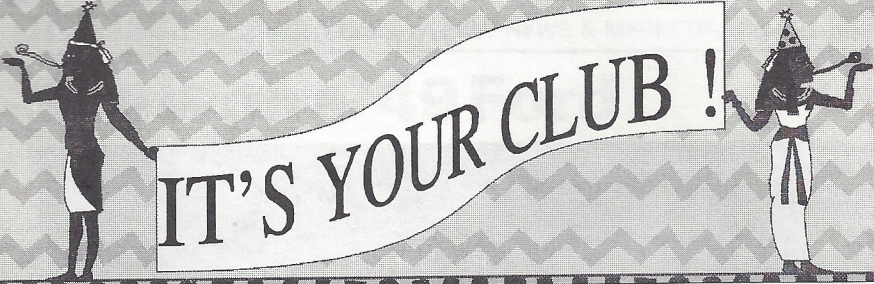

IT'S YOUR CLUB !

**VOLUNTEER TO BRING COOKIES FOR THE
UPCOMING MEETINGS.**



**PUT IN A LITTLE EFFORT...
GET A LOT OF ENJOYMENT
OUT OF IT !**



JUST SAY YES!



CATHOLIC CHARITIES

MOEED KHAN, LCSW
REGIONAL DIRECTOR
SAN FERNANDO VALLEY PASTORAL REGION

CARDINAL ROGER MAHONY
ARCHBISHOP OF LOS ANGELES

REV. GREGORY A. COX
EXECUTIVE DIRECTOR

LOAVES & FISHES II

14525 DELANO STREET, #102 • VAN NUYS, CA 91411 • (818) 997-0-943

January 4, 1995

Valley V8 Ford Club
5920 Lemona Ave.
Van Nuys, California 91411

Dear Club Members:

Once again Loaves & Fishes, in Van Nuys, was able to help several hundred families and homeless people during the Holiday season. Because of your generosity families went home with extra bags of food, over 500 children were given a new toy and many homeless were given gift certificates' to local markets.

It was such a pleasure for all the volunteers', who donate their time at Loaves & Fishes, to make so many people happy during this special time of year!

I can't thank you all enough for your generosity and kindness. I wish you all a Healthy and Happy New Year.

Warmest Regards,

Barbara Ausburn
Volunteer Director

Mystery tear drop

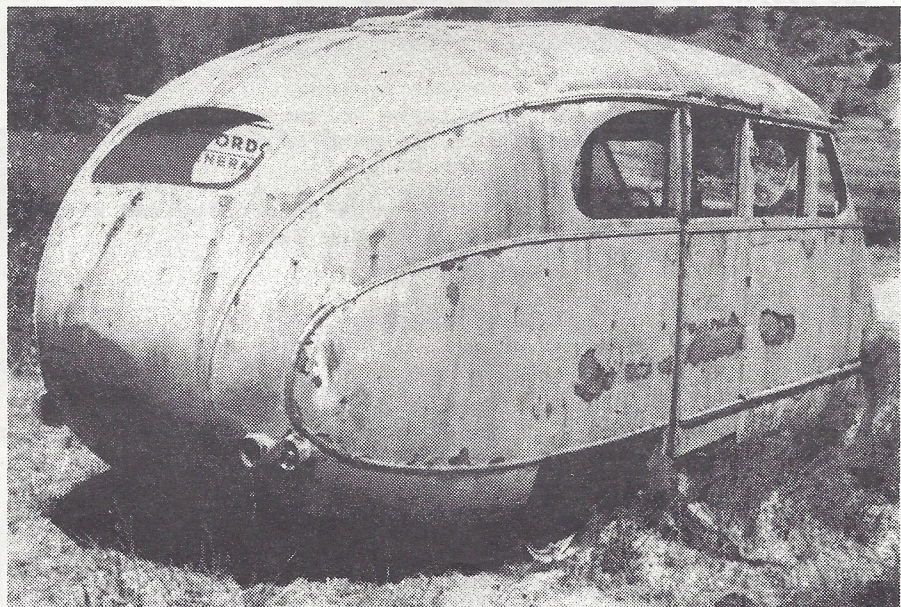

I came across this vehicle during a hunting trip in northern California. The current owner (a salvage yard) has no information on the vehicle. It has left-hand drive and a hinged entrance door on the passenger side. I would appreciate any information on it.

Fred Fischbach
Kenwood, Calif.

SUPPORT OUR ADVERTISERS!

BEV DUPRÉE

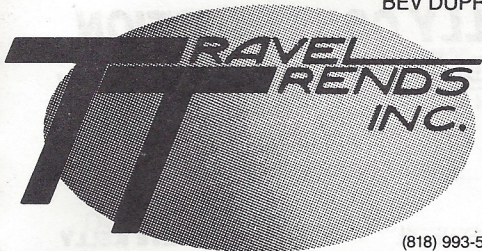

8902½ RESEDA BLVD.
NORTHRIDGE, CA 91324

(818) 993-5400
FAX (818) 993-3972
HOME (818) 883-2747

Flips
TIRE CENTER

FLIP SMITH

7735 Sepulveda Blvd.
Van Nuys, CA 91405
(818) 786-8686

DON'S
Auto Parts

MACHINE SHOP and BALANCING

Domestic &
Foreign

Parts & Supplies



Monday thru Friday 8 a.m. to 7 p.m.
Saturday 9 to 6 - Sunday 10 to 4

(818)
894-6441

10241 Woodley (At Devonshire)

Sepulveda, CA 91343

RAFFLE PRIZE DONOR

LESLEY A. LITTNER

(818) 597-9016 / FAX:597-9145

**BOOKKEEPING &
BUSINESS SERVICES**

5051 BLACKPOOL AVE.
AGOURA, CA. 91301



Older Cars
A Specialty

4 x 4's and
Motorhomes

Russell Sylvis, Inc.

Transmissions
Repaired • Rebuilt

4657 Barnard St.
Simi Valley, CA

(805) 527-4387

R.C. Smith's
Roofing Solutions

Roofing & Waterproofing • Complete Maintenance Service

8707-D Lindley Ave., Ste. 199, Northridge, CA 91325
Lic. #356650 (818) 718-2313

Auto • Homeowners

- ANTIQUE CARS -

ED HARDIN INSURANCE

Business • Life • Health • Aircraft



Call us for your Insurance needs!

(818) 363-7864

ALLAN FRANKLIN'S
BATTERY TENDER
\$59.99

Charges battery up and turns itself off
automatically when it fully charged.

Takes the guess work out of battery maintenance!

(818) 842-2230

6, 8, or 12 Volt Models

club members
\$54.99

SUPPORT OUR ADVERTISERS!

L.T. "LEE" SAWYER, INC.

Jobber

Shell Oil and Chemical Products

14117 Aetna Street, Box 369
Van Nuys, California 91408

TOM SAWYER (818) 786-8180 / (818) 785-0902

RAFFLE PRIZE DONOR

KELLY CONSTRUCTION AND ELECTRIC

LIC. # 657087

GENERAL CONTRACTORS

"Remodeling Specialists"

2558 Nicholas St.
Simi Valley, CA 93065

DAVE KELLY
Phone/Fax: (805) 520-6444

SCRAPPAGE UPDATE

Do scrappage programs make you mad? The present programs allow oil companies to buy up old cars in the smoggy areas and destroy them. The scrapped cars must have been licensed continually in the smoggy area, but nobody knows exactly how much the cars were driven every day. They might not have been driven at all. Even so, scrapping the cars gives the oil company "credits" for eliminating pollution. The "credits" are used by the oil companies to delay installation of pollution controls at their refineries. The atmosphere ends up with a small amount of lowered pollution from the scrapped cars, and continuing enormous pollution from the refineries. UNOCAL Corporation advertised on January 5 in L.A. for 1,200 cars, offering to pay \$600 for 1972-74's and \$700 for 1971 and earlier models. Within a week they had their 1,200 cars. These programs were started in several areas of the state by local air pollution control boards, without any vote or approval from the public.

These programs have been so successful that now the plan is to take them into all six of the smoggy areas in the state. There will be no oil company participation in the new plan. It comes direct from the California Air Resources Board (CARB), and they want to scrap 75,000 old cars per year. To get people to scrap their cars, CARB proposes paying \$1,000 for each car. And guess where that money is going to come from. It's coming right out of your pocket. If the California Legislature approves it, they will either add \$100 to the price of every new car, or put another \$1 on every renewal of vehicle registration, upping it to \$9 instead of the present \$8. (It was \$7 last year in the Los Angeles area. They just added another dollar January 1.) You can bet that the new car dealers are going to protest so much that the \$100 idea will be dropped, so that means they will get it \$1 at a time from you and me. If you don't like this idea, write to your California state assemblyperson or California state senator, and tell them that you don't want to pay for scrapping cars.

PAST PRESIDENTS

JIM ROWE.....	1971
DOUG PETERSON	1972
DON DURKEE	1974
ED WARNOCK	1975
JOHN BUSK.....	1976
CHIP WERSTEIN	1977
STAN MARSRAJE	1978
BOB DRAKE	1979
BILL CULP.....	1979
AL SPENCER.....	1980
LARRY CAPLAN	1981
BOB ROSE	1982
DON DURKEE	1983
PAUL KIRK	1984
KENT LOWRY	1985
DAVE SANBORN.....	1986
JOHN KEMMERER	1987
DUDLEY OCHSNER.....	1988
JERRY JENSEN	1989
JERRY JENSEN	1990
JOE DiFATTA	1991
CHUCK SHUBB.....	1992
CHUCK SHUBB.....	1993
GEORGE RICHARDS	1994

Meetings are held on the first Sunday of every month at 7:00 p.m.

The Valley  **'s**

5051 BLACKPOOL AVE., AGOURA, CA 91301

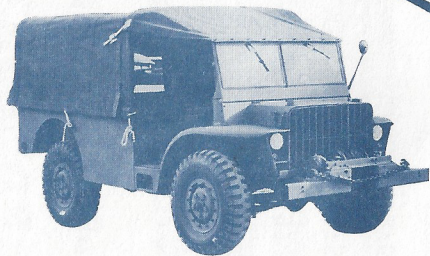
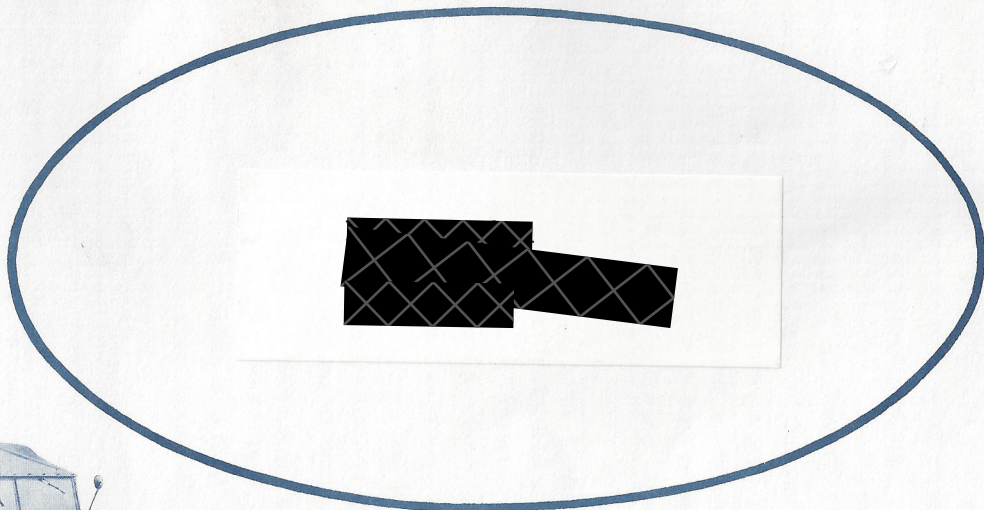

1945 Ford Cargo Truck