

13

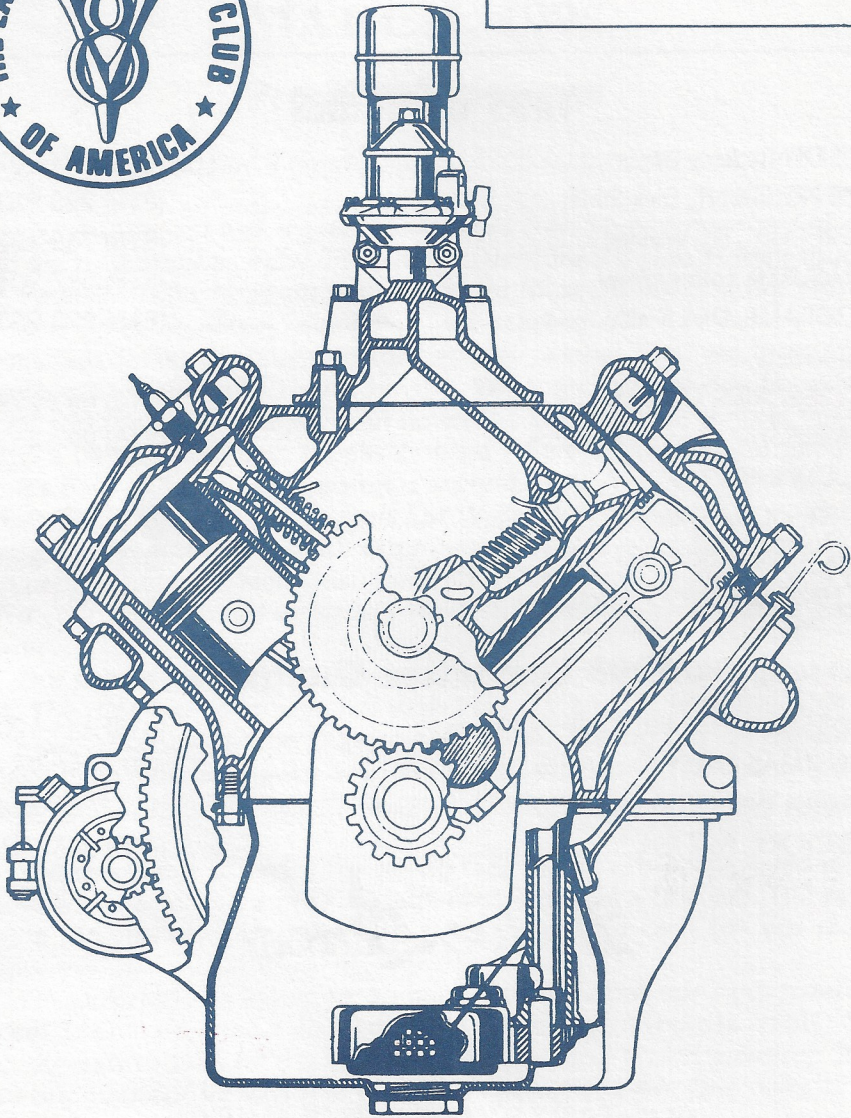

MARCH



Drive Lines

The Valley 's

1995 OFFICERS

| | |
|------------------------------------|----------------|
| PRESIDENT, Jerry Littner | (818) 597-9016 |
| VICE PRESIDENT, Dick Smith | (818) 993-9538 |
| SECRETARY, Jim Winnett | (818) 768-4228 |
| TREASURER, Lesley Littner..... | (818) 597-9016 |
| PROGRAMS, Dick Smith | (818) 993-9538 |
| ACTIVITIES | |
| ACCESSORIES, Chuck Shubb..... | (818) 882-2927 |
| MEMBERSHIP, George Richards..... | (818) 992-4537 |
| FELLOWSHIP | |
| RAFFLES, Chuck Mair | (818) 785-9413 |
| EDITOR, Miles Schofield..... | (818) 342-8881 |
| TECHNICAL ADVISOR, Don Dupree..... | (818) 883-2747 |

1995 Committee Chairmen

| | |
|--|----------------|
| ANNUAL PEPPERMILL, Dudley Ochsner..... | (818) 446-1206 |
| CHRISTMAS PARTY, Dick Smith | (818) 993-9538 |
| TEQUILA WILLIE'S, Bob Rose | (818) 362-4842 |
| DIRECTORY, Paul Kirk..... | (818) 886-5467 |

Drive Lines

Published By

SAN FERNANDO VALLEY CHAPTER 40
of the EARLY FORD V8 CLUB OF AMERICA

P.O. Box 96
Reseda, CA 91335

COVER/ROY JONES

The Valley V8's

MARCH, 1995

President's Message

GREETINGS VALLEY V-8ers:

I sure hope you had a great Valentine's Day. Several members of our club did by sharing an early one with the Ventura V-8 club at their tour of the Peterson Auto Museum and Miniature Museum last Sunday. Hosted by tour director, Gerry Blackwell, we started our day with yummy homemade boxes of Valentine cookies and sweets. Then we toured the Peterson Museum, which was terrific. We then headed out for a nice lunch and the Miniature Museum down the street. It was a great way to spend a beautiful Sunday. Thanks Ventura V-8ers for inviting our gang.

It's hard to tell what season it is around here. A couple of weeks ago some of us met up at the Cruisers Car Wash on Friday night only to find we weren't the only guys with cabin fever. What a great turn-out of cars and people and a perfectly warm evening. Hope to see some more of you drive your old cars and enjoy the friendship and technical advice we all shared.

Our second meeting of the year at our new location had a great turn-out. The meeting room was full with happy V-8ers. It feels like a good, cozy gathering place. Don Dupree gave an interesting talk on early Ford steering systems and even was the lucky winner of the name badge drawing. It's probably time to take his "lucky" card out of our drawing deck.

Thanks go out to Lesley for taking care of our raffle. She filled in for Chuck Mair, who had a prior engagement, and did a fine job. The raffle was a big success and helped to raise some cold cash for our club's treasury.

I'm looking for a volunteer to make the coffee at our April meeting. "Real Men" do make coffee. Our secretary, Virginia Wolf, has volunteered to take on the task for our upcoming March meeting. She's also bringing our cookies this month. What a great gal. One more brave person is needed for the month of April!

The March meeting will feature a video on Ford - the Man and the Machine. Hope to see you there.

Best regards,

Your Pres. Jerry

Program for March 5, 1995

**GLENDALE FEDERAL SAVINGS
21821 DEVONSHIRE, CHATSWORTH**

TIRE KICKING: 7:00 P.M.

MEETING: 7:30 P.M.

As of this printing, a couple of programs are being decided on for our March meeting...However, plan to attend, it's always a great evening to drive your classic!

A potpourri from 1935

Sixty years ago, Ford Motor Co. was looking to 1935 to recoup from several years of economic woes endured as the nation reeled from the effects of its worst ever economic depression. This column is a look back at that year from a different perspective. Instead of concentrating on the new 1935 models, here are facts and anecdotes — trivia, if you will — from the Ford world of 1935.

Damn the torpedoes

In the autumn of 1934, Henry Ford confidently announced that he planned to sell 1,000,000 Fords "or better" in 1935. Coming off a production of less than 600,000 for 1934, this prediction and the fighting spirit it typified impressed the editors of *Time* magazine so much that they featured the portrait of Henry on the cover of their Jan. 14, 1935 issue. The caption read, "He damned the torpedoes," a reference to Farragut's famous orders at Mobile Bay during the Civil War.

As it turned out, Henry Ford's prediction was nearly on the mark. Ford was America's best-selling car in 1935 with a calendar year production of 942,439 units.

U.S. greets '35 Ford

During the closing days of December 1934, a total of 8,683,900 visitors crowded the showrooms of Ford dealers to view the new Ford V-8 car for 1935. This was approximately 73 percent more than the

number that greeted the Model A at its introduction in December 1927. From the beginning sales were up. Some dealers reported that during the introductory period, sales on the floor were 40 to 50 percent of their total sales for 1934. By the end of June, 634,961 Ford units were sold in the United States.

The auto they deserted

On Feb. 6, 1935 two young fugitives from the law drove up in front of a house in Dallas, Texas. Surprised by police, a gun battle ensued during which the two

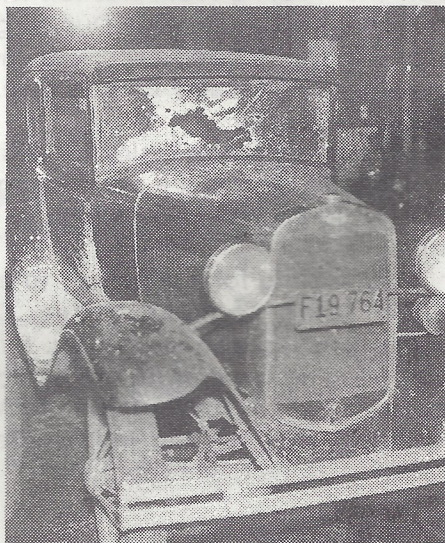

Two fugitives abandoned this Ford Model A in Dallas, Texas.

SECRETARY'S VIEWPOINT

Our first meeting in our NEW meeting place was GREAT! We had one of our better turn outs. The sign on the wall said that the room capacity is 46. We were very close to that limit.

President Jerry Littner started the meeting off by asking if there were any guests? Amadah Winnett was on hand to take some pre-orders for Girl Scout Cookies. And William Toensing paid us a surprise visit. It is always nice to have members who have moved out of the area to come to our meetings, when they are in town.

After all my shuffling and Dick Smith's cutting of the cards, the name that was picked for the Name Badge Drawing was, once again, DON DUPREE, and he was wearing his Name Badge...so he gets the \$20.00.

Vice President Dick Smith asked if Club Members would be interested in having a Car Club Plaque and he had a favorable response. Sometime in the near future we should be able to purchase a Car Club Plaque.

Our speaker for the evening was our own club Technical Advisor, Don Dupree. Mr. Dupree spoke to us about "Steering Boxes". Don showed us the difference between the '36 and earlier steering boxes and the ones made after 1936, which use the "Worm Gear". Don explained that if you have a little play in your steering it can take just a little adjustment to correct the play. If you need more information, his phone number is on the front inside cover of the Drive Lines.

Thanks goes out to Dave Sanborn for the delicious fudge that we consumed, "Couldn't eat just one," said Chuck Shubb.

With kindest regards, I am

Respectfully, Jim Winnett

EARLY V-8, FORDS, DRIVEN

- '33 Truck - Chuck Shubb
- '39 Convertible - Richard Chutuk
- '39 Deluxe Tudor - Jerry Jensen
- '40 Tudor - Larry Caplan
- '40 Convertible - Kent lowry
- '40 Tudor Deluxe - Ken Sapper
- '40 Coupe - Virginia and John Wolf
- '46 Pickup - Don Dupree

This probably shouldn't be mentioned on the same page as the others, but he did come to the meeting...that is Ernie Baily in his '48 Plymouth???

And Vice President Dick Smith came in his new toy....a 1965 Cobra....NICE!! He said he would give rides!!!!

REFRESHMENTS SIGN - UP

- | | |
|------------------------|---------------|
| March - Virginia Wolf, | August - |
| April - Jim Winnett, | September - |
| May - Dick Smith, | October - |
| June - | November - |
| July - | January '96 - |

We need volunteers, you DO NOT have to bake if you do not want to, you can purchase pre - packaged goodies..... We will eat just about anything... Please help out!!! Bring your favorite treat, the month you sign up for...

CARS & PARTS FOR SALE

'55 Pontiac 4 dr., '66 Citroen 10-19 sedan, '56 Packard Patrician, '47 Hudson Super 6 Coupe..Trade one or more for GOOD Model A Tour car..William J. Toensing (916)477-1128.

Garage Space for TWO cars in Van Nuys, Fenced and Alarm...Joe DiFatta (818)782-9883.

'38 Standard Humpback Deck lid - Nice \$100.00...Dudley Ochsner (818)793-5104

'34 Ford Tudor, '51 Chevy 2 door, '61 Chevy, '42 Ford 4 dr., '65 Chevy 4 dr, '58 Chevy 39M...Irv Warren..(818)780-6811.

CARS & PARTS WANTED

2 Headlight nuts for '35 Ford, Allan Franklin..(818)842-2230

'40 Ford Front Spring, Ken Sapper..(818)362-5865

JACKPOT



\$20.00
Could Be Yours!

(You just have to be present and wear your name badge to win.)

LET'S PLAY HOOKY!

**RETIRED MEMBERS OR
THOSE MEMBERS THAT WANT TO
TAKE 1/2 DAY OFF FROM WORK!**

**CRUISE IN YOUR CLASSIC CAR TO DON &
MARY DURKEE'S HOUSE & GARAGE**

1. Wednesday, March 8th
2. 11:00 a.m. Arrive at Millie's Restaurant
(corner Vanowen & Balboa - eat on your own)
3. 12 Noon exactly - leave Millie's and cruise to
Durkee's and tour at another member's home
4. R.S.V.P. to Joe DiFatta (805) 295-8788 or at home
(818) 700-1939

Fords & Friends

Don Durkee

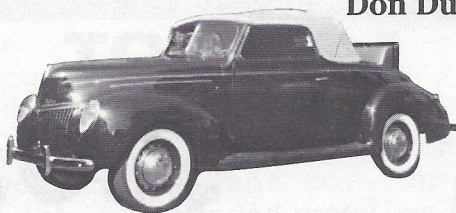

Phone: (805) 495-5298

736 Brush Hill Rd., Thousand Oaks, CA 91360

THE IOWA FARMBOY

BY: DON DURKEE

It all started on February 11, 1939 when I was born - weighing in at 9 and a half pounds. My Dad and Mom had not started farming yet. In March that same year, my parents and myself, one month old, moved from Grandma's house to a farm of our own 2 miles away. We loaded everything we had on a hay rack. Mom and me drove the horses while Dad drove 4 cows and 10 pigs up this country road to our new home - 120 acres of farm land with a very poor house to live in. We had no car because Dad sold the '32 Ford coupe to buy the 4 cows and 10 pigs and 2 work horses - so he could get started farming. Some neighbors gave them furniture so Mom could set up housekeeping. Dad farmed with the 2 horses the first year with help from some of the neighbors. The next year he was able to buy an old used tractor, a 10-20 McCormick Deering and a \$15.00 Model A coupe. That following year, in 1940, I got a new brother.

In 1942 we moved to another farm which was bigger and by 1943 we got another brother which made 3 boys. Well the Model A coupe had to go and Dad made a mistake and bought a used 1935 Chevy 2-door. He was smart to buy a new Ford tractor that took all of his money - so that's how the used old Chevy came to the Durkee household. The next year, 1944, we got another new brother and, by 1945 the old Chevy went to the junk yard. Then World War II was going on and cars were impossible to find, so Dad ended up with another old Chevy - a 1937 which was hard to start. So once in a while Mom would have to pull the Chevy with the little Ford tractor, until one day she jerked the front bumper off from the old Chevy. The front bumper never did get put back on and they hung on to that old Chevy until September, 1946 when the new '47 Kaiser came out. Fords were too hard to get and Mom said anything would be better to drive than that old ugly Chevy.

Besides buying a new car in 1946 they bought their first farm. No more renting and moving every 2 years. This is the farm that I remember growing up in with my 3 brothers. We didn't have any sisters which was all right with us 4 boys because we didn't think we liked girls. Dad always had plenty of help on the farm, but my Mom got short-changed because all us boys were not any good at helping with the housework and my Dad wasn't any better. Mom never complained about all the housework. She was glad she had all boys to help with the farm chores which she hated.

In 1953 we got our first brand new Ford car and, by this time we already had owned several new tractors - all of them Fords. By 1955 when I got my driver's license, Dad said with my 3 younger brothers, he had enough help at home and I should look for a job in town for the summer. In June, 1955 I went to work for Modern Motors Ford dealer in Maquoketa, Iowa, five miles north from our farm.

Too far to walk and my Whizzer could not be depended on for every day. So I traded by Whizzer Motor Bike and \$145.00 for my first car, a 1946 Ford club coupe. One year later I traded my '46 coupe for my 2nd car, a 1950 Ford club coupe - which I had through most of high school and fond memories. Since I sold my maroon coupe a couple of years ago, I am currently restoring another '50 club coupe. The E.T.C. "expected time of completion", should be this summer.

One week after high school I went to the Army. While I was in the Army and home on leave, I purchased an all black 1952 Mercury 2 door hardtop. So I guess that's why today I own a 1953 Mercury 2 door hardtop. After the Army I went back to that same Ford dealer to learn the auto body trade. My third car was a '55 Mercury Montclair 2 door hardtop - red and white, which later I painted all black. The '55 Mercury was the car in which I courted M.C. - "Mary Carreher". After 2 years I made her an M.D. - "Mary Durkee".

Shortly after we were married, my best friend sold me his 1940 Tudor with a bad motor for \$25. I found a '49 motor and O.D. transmission for \$10 and sold the overdrive transmission for \$35 - so now I have a free 1940 Tudor with a good '49 motor. I later sold the '40 for \$150 and that started my love with '40 Fords.

When Kathy, our first daughter was 3 months old I found our first '40 Ford convertible. I had never seen one before. Our '40 Ford convertible was my work car for the next two years. By this time our second daughter Connie had arrived. Connie was only 6 months old when we decided to move west to a warmer climate. First Prescott, AZ for 7 months then on to Ventura, California. Our '40 convertible was used as a trailer when we left Iowa - towing it with our '57 Ford Fairlane 2 door hardtop. We had everything we owned in the '57 and our '40 convertible. When we moved to Prescott my wife spent \$35 for the complete furniture for our house - which we rented for \$75 a month.

While in Ventura we sold our '40 convertible so we could have a new car which we did - a 1964 Chevy, 1966 Chevy, 1967 Chevy and 1969 Ford LTD. Also in 1964 our son Jim was born. The 1969 new car thing was not as exciting as we thought it would be. We decided to sell the new car, 6 months old and paid for and put the money in the stock market. The money doubled several times and we thought this was the way to go, until sometime in 1970 when the stock market went the other way, "bad". I sure did not like that money lesson. Late in 1970 we got out of the stock market and back into the old car game again. Even when you lose money on old cars it is a lot more fun than to lose it in the stock market. Fortunately, the old cars have been very good for us.

You see every time I went out and bought an old car, my wife would go out and buy an old house. She just wanted to keep the money spending even. I never caught on why she wanted to buy old houses until I became 50 years old and wanted to retire. Now the old houses are starting to pay off.

Over the years I have had many old cars and sold some to help pay for some of them old houses. I am now glad somebody in our family had the foresight for these "Golden Years". Thank God for the M.D. in our family.

Don L.D.

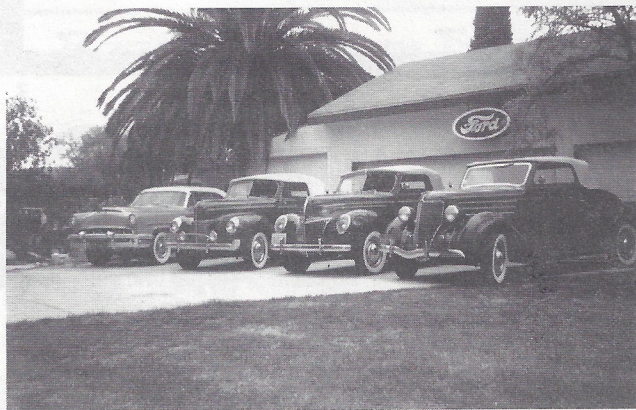
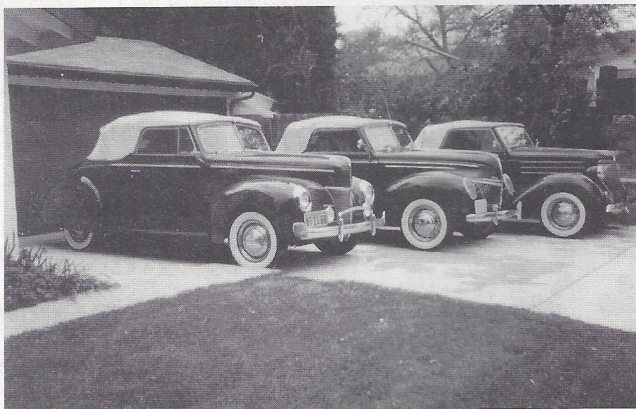
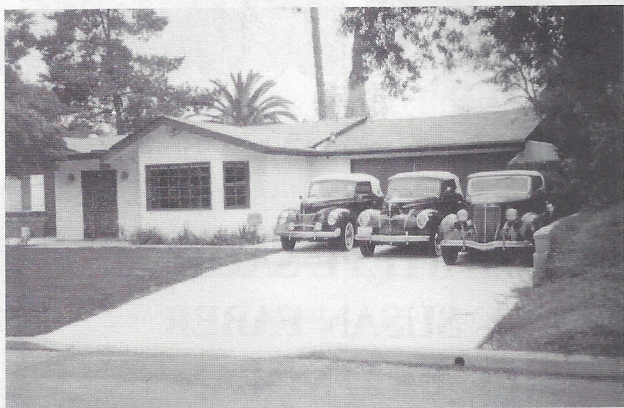



MARCH V-8 BIRTHDAYS

3/03 STEVE SADD
3/12 SUSAN FABER
3/15 BILL NOLAN
3/16 TOM REILA
3/18 ED WARNOCK
3/18 RUTH MOTTERN
3/21 DENNIS KEENE
3/25 KENT LOWRY
3/26 SHARON FOSTER
3/30 RUTH THOMPSON

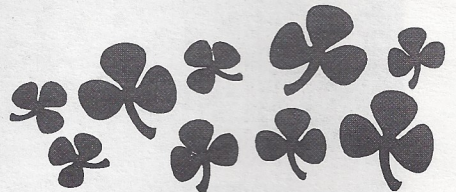
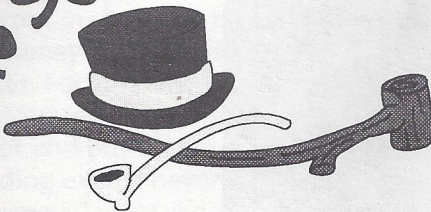

THE FRESNO COUNTY

BLOSSOM TRAIL

To fully appreciate
the blossoms & wild flowers
The Chamber of Commerce of Reedley
Advised us that the date of our tour
should be

March 18 & 19

Make reservations by March 4

The Edgewater Inn, Reedley

1-800-479-5855

Dinner - Reedley Opera House

Contact Gerry & Blacky Blackwell

805-268-0040

Reedley Opera House

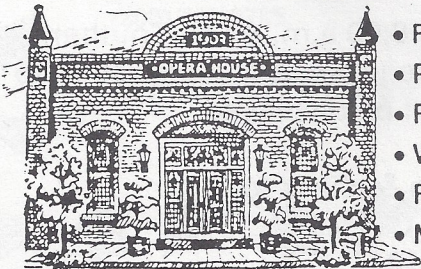

- Fundraisers
- Private Parties
- Reunions
- Weddings
- Receptions
- Meeting Rooms

1720 10th STREET • REEDLEY, CA 93654
(209) 638-1900

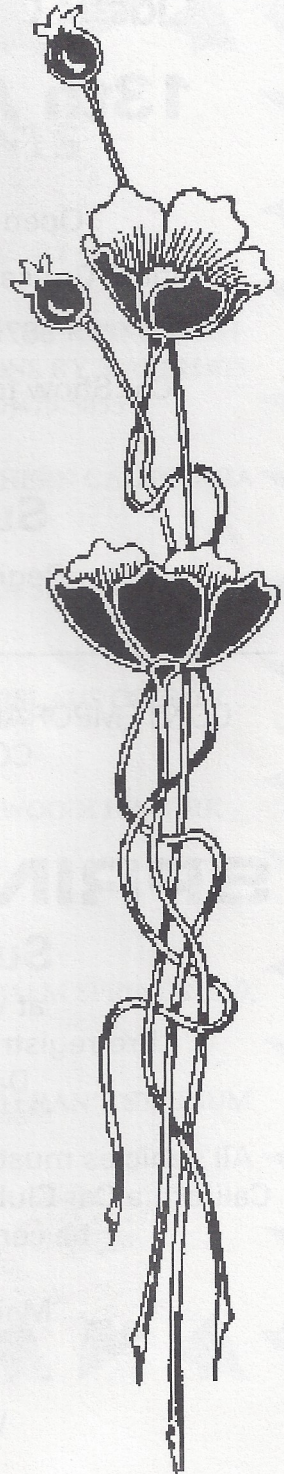

Classic Chevys of Southern California

13th Annual Car Show

Open Event...All Vehicles Welcome!

Location: Cruisers Car Wash in the Price Club Parking Lot

8870 Tampa Avenue, Northridge

Car Show to be held in Secure, Partitioned Area

Sunday, May 7, 1995

Registration 9:00 a.m. to 12 Noon

CONTEMPORARY HISTORICAL VEHICLE ASSOCIATION
COASTAL VALLEY'S REGION

presents

Our Sixth Annual

SPRING CAR SHOW

Sunday, April 9, 1995

at Woodley Park (on the grass)

Pre-registration only \$12.00 until April 3, 1995

Day of show registration \$15

All vehicles must be in place by 10:00 a.m. As all Southern California Car Clubs are invited, we urge early registration to be certain your car will be displayed.

Mail you entry form & check to:

Coastal Valleys C.H.V.A.

P.O. Box 2194

Winnetka, CA 91396-2194



UPCOMING EVENTS

MARCH 12 - POMONA SWAP MEET

MARCH 18 & 19 - SPRING BLOSSOM TOUR TO FRESNO WITH THE VENTURA CLUB. MAKE RESERVATIONS BY MARCH 4TH. THE EDGEWATER INN - REEDLEY, CA. (800)479-5855

MARCH 19 - MUSTANG OWNERS OF SOUTHERN CALIFORNIA CAR SHOW AT WOODLEY PARK

APRIL 2 - FABULOUS FORDS FOREVER CAR SHOW AT KNOTT'S BERRY FARM - (310) 935-8905

APRIL 2 - TURLOCK SWAP MEET AT STANISLAUS COUNTY FAIRGROUNDS (209) 358-3354

APRIL 9 - C.H.V.A. SPRING CAR SHOW AT WOODLEY PARK - CHUCK SHUBB - 882-2927

APRIL 7-9 - PORTLAND SWAP MEET

APRIL 8 & 9 - SPECTRUM CAR AUCTION, PALM SPRINGS (619) 323-2257 / (818) 225-8828

APRIL 9 - LONG BEACH SWAP MEET - VETERAN'S STADIUM (800) 762-9785

APRIL 23 - POMONA SWAP MEET



F.Y.I. - REFERENCE LIST

LICENSE PLATE RESTORATION:

DARRYL'S

4505 8th Ave So.,A-10,St. Petersburg, FL. 33711

(813) 321-8279

A.V. POLIO

746 North Greenbrier Dr.,Orange, CT. 06477

(203) 795-6434

RUNNING BOARD RESTORATION:

HUNLEY ACUFF

1423 Wilson Road,Rossville, Georgia 30741

(706) 866-4875

TRANSMISSION REBUILDING:

RUSS SYLVIS

4657 Barnard,Simi Valley, CA. 93063

(805) 527-4387

STAINLESS TRIM RESTORATION:

MIKE'S OLD CARS

3017 Pico Blvd., Santa Monica,CA.90404

(310) 453-2450

GAS TANK & RADIATOR WORK:

NORTHRIDGE AUTO WRECKING INC.

LARRY READY - 18959 Parthenia, Northridge, CA. 91324

(818) 886-3660

SUPPORT OUR ADVERTISERS!

BEV DUPRÉE

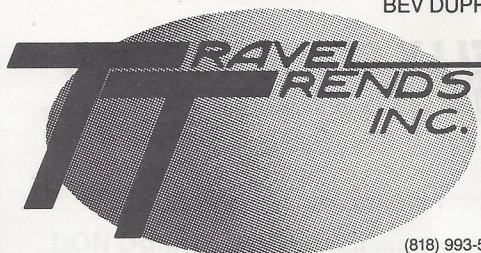

8902½ RESEDA BLVD.
NORTHRIDGE, CA 91324

(818) 993-5400
FAX (818) 993-3972
HOME (818) 883-2747

Flips
TIRE CENTER

FLIP SMITH

7735 Sepulveda Blvd.
Van Nuys, CA 91405
(818) 786-8686

DON'S
Auto Parts

MACHINE SHOP and BALANCING

Monday thru Friday 8 a.m. to 7 p.m.
Saturday 9 to 6 - Sunday 10 to 4

10241 Woodley (At Devonshire)

Domestic &
Foreign

Parts & Supplies



(818)

894-6441

Sepulveda, CA 91343

RAFFLE PRIZE DONOR

Older Cars
A Specialty

4 x 4's and
Motorhomes

Russell Sylvis, Inc.

Transmissions
Repaired • Rebuilt

(805) 527-4387

4657 Barnard St.
Simi Valley, CA

LESLEY A. LITTNER
(818) 597-9016 / FAX:597-9145

**BOOKKEEPING &
BUSINESS SERVICES**

5051 BLACKPOOL AVE.
AGOURA, CA. 91301



Older Cars
A Specialty

4 x 4's and
Motorhomes

Russell Sylvis, Inc.

Transmissions
Repaired • Rebuilt

(805) 527-4387

4657 Barnard St.
Simi Valley, CA

R.C. Smith's
Roofing Solutions

Roofing & Waterproofing • Complete Maintenance Service

8707-D Lindley Ave., Ste. 199, Northridge, CA 91325
Lic. #356650 (818) 718-2313

Auto • Homeowners

- ANTIQUE CARS -

ED HARDIN INSURANCE

Business • Life • Health • Aircraft



Call us for your Insurance needs!

(818) 363-7864

ALLAN FRANKLIN'S
BATTERY TENDER

\$59.99

club members
\$54.99

Charges battery up and turns itself off
automatically when it fully charged.

Takes the guess work out of battery maintenance!

(818) 842-2230

6, 8, or 12 Volt Models

SUPPORT OUR ADVERTISERS!

L.T. "LEE" SAWYER, INC.

Jobber

Shell Oil and Chemical Products

14117 Aetna Street, Box 369
Van Nuys, California 91408

TOM SAWYER (818) 786-8180 / (818) 785-0902

RAFFLE PRIZE DONOR

KELLY CONSTRUCTION AND ELECTRIC

LIC. # 657087

GENERAL CONTRACTORS

"Remodeling Specialists"

2558 Nicholas St.
Simi Valley, CA 93065

DAVE KELLY
Phone/Fax: (805) 520-6444



(818) 776-3290
FAX (818) 776-3291

TERRY Sash & Door

6057 Reseda Boulevard, Tarzana, CA 91356

"Able to service all your Sash & Door needs"

RESIDENTIAL • COMMERCIAL • INVESTMENT



Spencer Realty

3948 Goodland Ave.
Studio City, CA 91604
Office: 818-761-1754
Fax: 818-761-7952



AL SPENCER

QUALITY PROFESSIONAL SERVICE

HOW TO IMPROVE YOUR MENTAL HEALTH

In the paper the other day there was an article about the dangers of purchasing too many toys, and how it can dull the mind. Forty years ago the average American 5-year-old owned less than 10 store-bought toys. Today the average kid has 100, not counting the ones he lost, broke, or threw away.

The people who know about these things are worried that an excess of toys dampens imagination, ruins creativity, destroys resourcefulness, and leads to boredom. At some point a person with too many toys becomes addicted, not to the toys themselves, but to the hollow thrill of getting a new toy.

Perhaps this addiction is a danger to adults, as well. Is it possible that you are addicted to getting another Flathead? Do you spend all your time searching for another car instead of playing with the ones you already have? Is maintenance being put off, and driving ignored, while you rush each Thursday to get the latest Recycler in hopes of finding another car or pickup? Do you have the Acquisition Disease?

This can be a serious illness, interfering with life, love, and family happiness. We would hate to see this happen to any member, so in the spirit of helpfulness we have devised a plan for relief. The next time you hear of any fabulous deal on a car, just call your Drivelines Editor. Don't bother with advertised cars. Just tell me about the '32 V-8's in Pasadena for a few hundred bucks, or the flathead convertible that somebody wants to give away because it hasn't been driven for 20 years. My number is in the roster. I will then go out immediately and get the car, thus saving you from the onslaught of the Acquisition Disease. It's a sacrifice to do this, because it will plunge your editor deeper into the illness, but what the heck, the mental health of our members comes first. And besides, I don't have to worry, because if a 5-year-old can have 100, at my age I ought to be allowed more than 1,000.

M.S.

PAST PRESIDENTS

| | |
|-----------------------|------|
| JIM ROWE..... | 1971 |
| DOUG PETERSON | 1972 |
| DON DURKEE | 1974 |
| ED WARNOCK | 1975 |
| JOHN BUSK..... | 1976 |
| CHIP WERSTEIN | 1977 |
| STAN MARSRAJE..... | 1978 |
| BOB DRAKE | 1979 |
| BILL CULP..... | 1979 |
| AL SPENCER..... | 1980 |
| LARRY CAPLAN | 1981 |
| BOB ROSE | 1982 |
| DON DURKEE | 1983 |
| PAUL KIRK | 1984 |
| KENT LOWRY | 1985 |
| DAVE SANBORN..... | 1986 |
| JOHN KEMMERER | 1987 |
| DUDLEY OCHSNER..... | 1988 |
| JERRY JENSEN | 1989 |
| JERRY JENSEN | 1990 |
| JOE DiFATTA | 1991 |
| CHUCK SHUBB..... | 1992 |
| CHUCK SHUBB..... | 1993 |
| GEORGE RICHARDS | 1994 |

Meetings are held on the first Sunday of every month at 7:00 p.m.

The Valley 's

5051 BLACKPOOL AVE., AGOURA, CA 91301

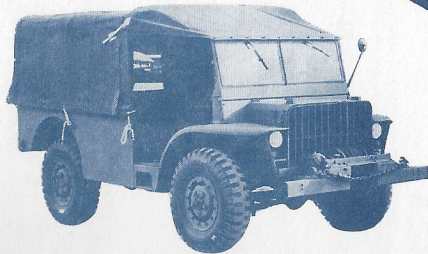
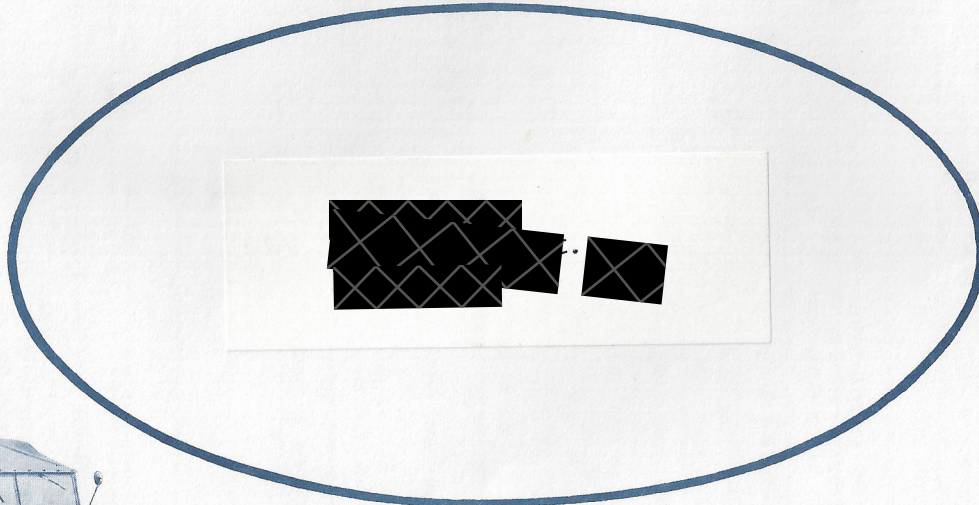

1945 Ford Cargo Truck

