

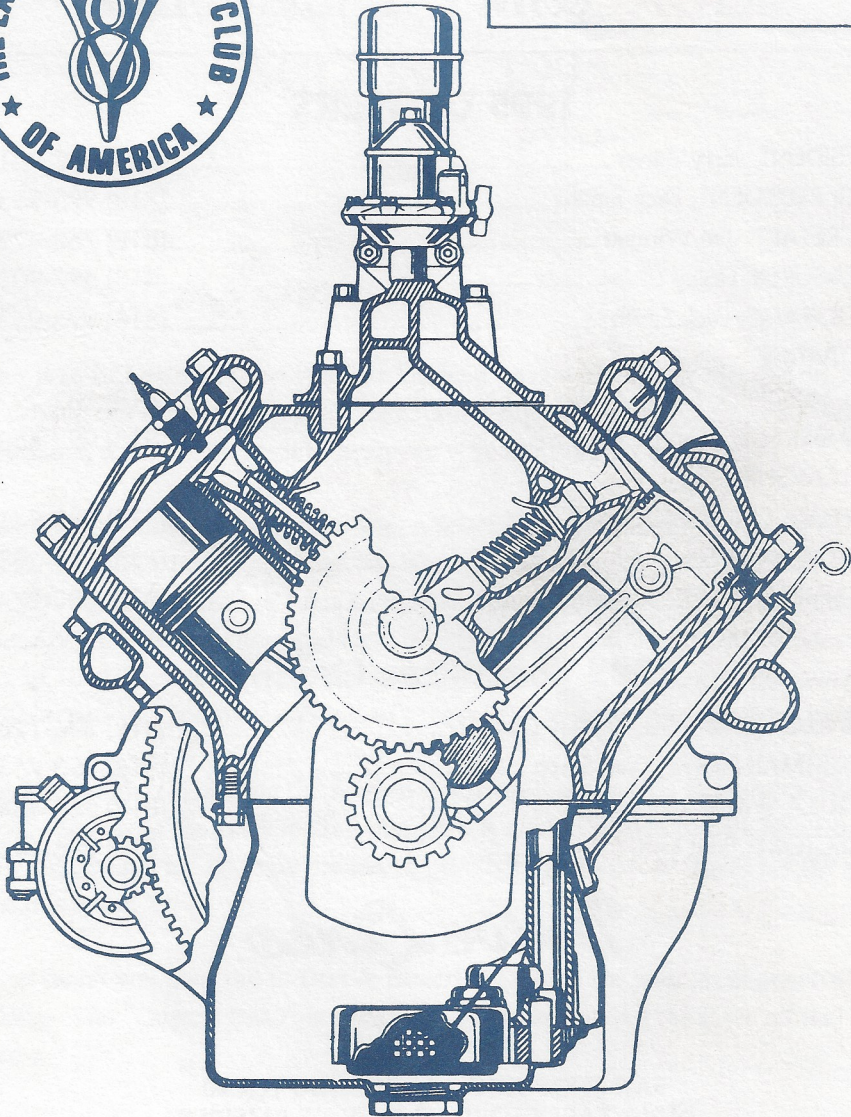

AUGUST



Drive Lines

The Valley 's

1995 OFFICERS

PRESIDENT, Jerry Littner	(818) 597-9016
VICE PRESIDENT, Dick Smith	(818) 993-9538
SECRETARY, Jim Winnett	(818) 768-4228
TREASURER, Lesley Littner.....	(818) 597-9016
PROGRAMS, Dick Smith	(818) 993-9538
ACTIVITIES	
ACCESSORIES, Chuck Shubb	(818) 882-2927
MEMBERSHIP, George Richards.....	(818) 992-4537
FELLOWSHIP	
RAFFLES, Chuck Mair	(818) 785-9413
EDITOR, Miles Schofield.....	(818) 342-8881
TECHNICAL ADVISOR, Don Dupree.....	(818) 883-2747

1995 Committee Chairmen

ANNUAL PEPPERMILL, Dudley Ochsner.....	(818) 446-1206
CHRISTMAS PARTY, Dick Smith	(818) 993-9538
TEQUILA WILLIE'S, Bob Rose	(818) 362-4842
DIRECTORY, Paul Kirk.....	(818) 886-5467

Drive Lines

Published By
SAN FERNANDO VALLEY CHAPTER 40
of the EARLY FORD V8 CLUB OF AMERICA
P.O. Box 96
Reseda, CA 91335

COVER/ROY JONES

The Valley V8's

PRESIDENT'S MESSAGE

AUGUST, 1995

GREETINGS VALLEY V-8er's:

Summer is in full-swing. Lots of us are keeping busy with old car restoration. Some of us are driving our old beasts to events and cruise nights and national meets. Whatever your pleasure, it sure feels great to hang-out with our old cars and friends.

Our meeting this month on August 6th is a Special Event Meeting. We will be meeting at Cruiser's Car Wash in Northridge for "Odometer Trophy Night". Invite your friends and family to join us. Cruiser's has been kind enough to keep their kitchen and facilities open for us - so come and have dinner if you want. There will be odometer judging of all 1923 - 1969 Fords, Lincolns and Mercurys. Trophies will be awarded. Fun will be had. A big crowd and lots of cars would be great. See insert for more info.

Once again our club is hosting the Annual Peppermill Brunch on September 17th in Pasadena. Six clubs are participating this year. It always proves to be a lot of fun. Judging and awards are done by the ladies - so sign them up too! Look for the sign-up sheet in this issue.

A special thank you goes out to Don & Beverley Dupree for your great generosity and hospitality. The "Dupree BBQ" is always a favorite of mine. I think we all had a really good time.

Our Christmas Party planning is in the works and there will be a flyer in next month's Drive Lines telling you all about it. We are booking it on Sunday, December 3rd - so mark your calendars.

Looking forward to more cruising and schmoozing.

Your Prez. Jerry

SECRETARY'S VIEWPOINT

Meeting #7 of 1995 was not like any other meeting we had thus far, this year. First, the meeting was NOT on the first Sunday of the month and second, it was not held in a "Meeting Room". We (Those of us who attended) got the privilege to be at Bev and Don Dupree's for the first annual "Past Presidents" barbecue, with several past presidents in attendance.

There was the usual kicking of tires and "shop talk" and there were guests. The guests were; John Busk, Greg, Jin and Kelly Lovell (The owners of the Valley Ford Obsolete Parts), Chuck Misetich and Jennifer Shellenberger a.k.a. Joe DiFatta's granddaughter.

The meeting was a social event which included a barbecue with three barbecues cooking. Two were cooking hamburgers (Chef Leslie Littner at one and chef Dennis Keene at the other) and I handled the wieners, but not before chef Leslie scored them with a knife, on the third. Joe DiFatta was the alternate that was used when Leslie and Dennis were relieved of their spatulas. And I was relieved because they heard I was going to write about it.

There was ice cream that you could decorate the way you liked and then there were the "Bingo" games. With Dennis Keene at the balls (the caller) and Leslie Littner as the varifier.

There were four bingo games played. Al Schmitt won the first game; Dave Sanborn, Jennifer Shellenberger and Virginia Wolf tied on the second game; Dave Sanborn won the "H" (H for Henry Ford) /third game; and I won the "Blackout"/fourth game.

Thank you Bev and Don Dupree for letting us into your beautiful home, once again. As always, the atmosphere was friendly and warm.

Respectfully, Jim Winnett

EARLY V-8s, FORDS, DRIVEN

'31 FORD - Judy and Chuck Shubb

'32 FORD "Sissy Car" - Patti and Dick Smith

'36 FORD Roadster - Virginia and John Wolf

'39 FORD - Shirley and George Richards

Chuck Mair arrived in a 1963 Pontiac Convertible

This is another gathering where there were other EARLY V-8s Driven but not everyone signed the attendance sheet.

CARS AND PARTS FOR SALE

(2) '40 Ford hoods- (1) deluxe, (1) standard
Steve Moody (818) 545-9344

1946 Ford Business Coupe, Straight, Original car. Fresh flathead.
Car is apart.

Lawrence Clemans (818) 888-1812

REFRESHMENTS

AUGUST - Chuck Shubb

NOV. -

SEPTEMBER - Blacky Blackwell

JAN. '96 -

OCTOBER - Jerry Jensen

We, still, have two openings for some aspiring bakers to use this club as a testing place for a new creation. This could be the opportunity that may help your dreams come true!!!

A decorative border surrounds the text, featuring various fruits and leaves. On the left side, there are clusters of grapes, a pear, and several leaves. On the right side, there are more grapes, a pear, and leaves. At the bottom, there are clusters of grapes and leaves. The border is composed of black silhouettes of these items.

AUGUST V-8 BIRTHDAYS

8/03 CAROLE JENSEN

8/03 LLOYD PASCHAL

8/04 CHRISTINE VARNEY

8/05 TOM SAWYER

8/05 GRANT LIPPERT

8/07 DENIZE NOLAN

8/11 MARY FINLEY

8/11 BRIDGET WINNETT

8/12 JULIA OCHSNER

8/17 CARLOS WILHELM

8/19 GENE WILSON

8/23 VICKI KEENE

8/30 JACK KELEJIAN

Motorhead Ed

By Ed Warnock

My love affair with things with wheels, especially automobiles, and Fords in particular, goes back to my earliest memories. Scrounging in trash piles would sometimes yield cast off coaster wagon wheels and axles which I would attach to a two by twelve and then tow to the hill behind our house. The thrilling ride down is only duplicated in a Calvin and Hobbs cartoon strip.

Dad had a 1935 Ford 1 1/2 ton truck with a stock rack during the Second World War. I would spend hours sitting in the cab, shifting gears, pretending to drive and making engine noises as the truck sat quietly in our farm yard. By the time I was seven I would sit on Dad's lap and steer the Ford Truck down country roads. I credit that golden orange and black truck with my lifelong love of Fords.

My parents bought a new Willys Jeep in January 1948 and a couple of months before my eleventh birthday I was allowed to drive the mile and a half to the mailbox by myself. The following summer I drove a one horse hay rake during the hay harvest earning \$78. I bought a 1930 Model

A Fordor for \$65 and it kept me broke keeping it running.

Early in the summer of my thirteenth year I replaced the piston rings and tightened up the bearings of the Model A. After some trial and error and advice of some patient adults the little Ford ran just fine. As my mechanical experience and physical size increased I worked more on our family ranch, began maintaining our tractor and ranch equipment and, of course, increased my income.

The next summer I bought a nice, good running 1936 Ford pickup. Shortly after I was fifteen I traded the Model A in on a well worn 1940 Ford Deluxe Coupe with a good '42 Mercury engine. On my sixteenth birthday I got my Oregon drivers license - then the fun began. The Merc engine in the '40 was loose and fast. I built headers and added dual pipes. It sounded good with 18" echo cans.

During my High School years I sold the '36 pickup, bought a '36 five window coupe for \$75 (also with a Merc engine), rebuilt our jeep which had been worn out with the rigors of ranch work, disassembled the '40 coupe to be channeled and customized and bought three 1932

Model B Tudor sedans which cost \$20, \$35, and \$50. I had also hauled home the remains of a '36 cabriolet and a '34 cabriolet body. What I really wanted was a 1932 Ford roadster but it would be a few years before that dream would be realized.

The '40 coupe was channeled 4 inches, fitted with an Olds Rocket V-8 and Caddy side shift transmission driving a Lincoln Zephyr rear axle and Columbia two-speed to 8.20 by 15 tires. The coupe was a dark metallic blue, went to the Air Force with me in 1960 and sold in New Jersey in 1965.

During the past thirty years the '34 cabriolet body was sold to Jack Chard at a L.A. Roadster swap meet, the '36 coupe was restored by a former Valley V-8 member, one of the '32 Tudors was restored and the body of the third went to a street rodder in Northern California and was converted to a sedan delivery.

I was led astray while in the Air Force to a Triumph TR3 and two Mercedes, a '52 followed by a '62. The Mercedes' required constant maintenance and repair and caused me to never own another foreign automobile. Today, it's gotta be built by FORD to be in my fleet.

FOR IMMEDIATE RELEASE

By now you know all about the closing of a West Coast institution, Valley Ford Obsolete Parts in North Hollywood, California. However, we are pleased to report that although owner Bill Norton is indeed retiring to the rolling hills of South Central Texas, club members in the San Fernando Valley will still have a local parts source. Just before Bill's planned closing in April, a deal was struck with long-time vintage Ford enthusiast, Greg Lovell, to purchase a stocking inventory of new, N.O.S., reproduction and used parts to continue serving area customers from a new location in nearby Burbank. Greg's background includes some fifteen years in the auto parts business and a total of twenty-five years in the automotive aftermarket industry. He is very customer oriented, and believes in friendly service at reasonable prices.

The "new" Ford Obsolete Parts is located at 2126 Floyd Street, Burbank, CA 91504. You can still dial the old Valley Ford number, (818) 982-5303, or the new number, (818) 295-2685. The new fax is (818) 295-2699. Hours are 8:30 a.m. to 6 p.m., Monday thru Friday, and 9:00 a.m. to 3:00 p.m. on Saturday.

1st Annual Past Presidents Day B-B-Q

A grand time by all at the July/Aug meeting, honoring our club's past presidents.

The club thanks Don and Beverly Dupree for hosting this yearly event. Also, Dennis Keene provided us with Bingo and Lesley Littner for cooking.



(Back row) Jerry Jensen, Joe DiFatta, Al Spenser, Dave Sanborn, John Kemmerer, Dudley Ochsner, Paul Kirk, George Richards, Chuck Shubb. (Front Row) Doug Peterson, John Busk, Jerry Littner, Don Durkee and Larry Caplan.

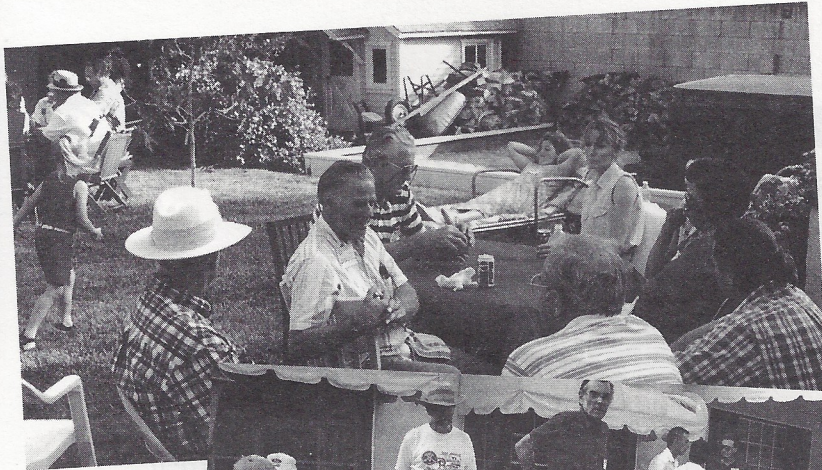

FELLOW FORD MEMBER

I've always been proud to be a member and President (1991) of the Valley V8's. It's a true sense of pride to drive my "Classic" to a meeting or a club tour.

A club is like a ship with a good crew...always in need of a leader. We've been very fortunate in the past years to have had great leadership. This year, Jerry and also Lesley Littner have devoted many hours to this club. Even the officers are on hand to assist at our functions.

We are always in need of new members and members to attend our meetings. Now we need new officers and a president for 1996.

It's has been said, "when you put thoughts in writing... you upset someone"... that is not my intention, my intention is making you aware that we are members of a great club.

Call either Jerry or myself and volunteer yourself for a position on the board and even president of the #1 Ford Club!

Thank You,

Joe DiFatta, President 1991

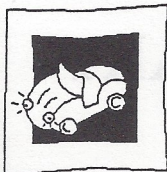

EARLY FORD V-8 CLUB OF AMERICA
VALLEY V-8'S HOST

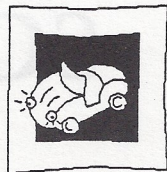

**TENTH ANNUAL
PEPPERMILL BRUNCH 1995**

Pasadena, California 91101

Baldy View	\$9.75 Per Person	Best of Show
Ventura	September 17, 1995	Ladies Awards
Southern Cal	Tire Kicking 9:30 a.m.	Prizes
San Diego	Doors Open 10:00 a.m.	Awards
Lincoln Club	Brunch served promptly at 10:30 a.m.	Fun
Central Coast		

RSVP by September 12, 1995

Make and mail checks to:

Dudley C. Ochsner
750 East Green Street, Suite 302
Pasadena, CA 91101
(818) 793-5104

Yes I will attend Peppermill 1995 on September 17th!

I have enclosed my check in the amount of \$_____ for _____ people.

Name _____ Regional Group _____

Phone _____

Tickets will be held at the door and can be picked up after 9:30 a.m.!

SCV *S*UNRISE *R*OTARY CAR *S*HOW AND *H*ISTORICAL *P*OKER *R*UN

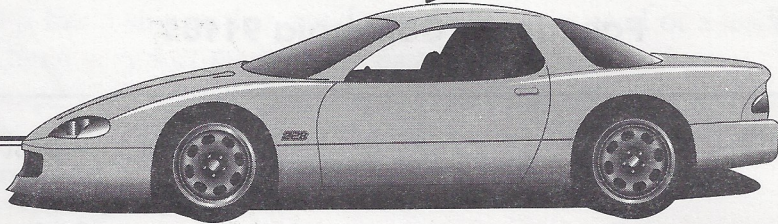

at

Santa Clarita Metrolink Station

(Soledad Canyon Road, East of Saugus Speedway)

Saturday, September 16, 1995

6 a.m. – 12 Noon

REGISTRATION: 6:00 a.m. to 9:00 a.m.

- SPECIAL RAFFLE, 1939 SSK
MERCEDES BENZ,
FIBERGLASS REPLICAR
\$5 TICKETS - 5 FOR \$20

- 50/50 RAFFLE
- ALL ENTRANTS DRAWING
FOR \$500 CASH

Schedule of Events

- 6 a.m. Gates Open
9 – 11 a.m. Judging by Participants
(not own class)
11:00 a.m. Awards Presentation
11:45 a.m. Poker Run Begins (\$5 Entry)

Classes

- A - Antique (prior to 1930)
- B - Customs
- C - Street Rods
- D - Trucks
- E - Sport Cars
- F - Classic/Stock (to '65)
- G - Classic/Stock ('66 & up)
- H - Muscle Cars
- I - Corvettes
- J - Motor Cycles
- K - Special Interest Vehicles

Presented by the SANTA CLARITA SUNRISE ROTARY CLUB
CORPORATE SPONSOR, Magic Ford, Valencia
Proceeds to Benefit Santa Clarita Valley Charities
FOR INFORMATION CALL (805) 789-5092

Helpers' Club of St. John of God



Italian Picnic and Classic Car Show

Sunday, August 6, 1995

1:00 P.M. to 4:00 P.M.

On the Grounds of the

Villa Maria

2035 West Adams Boulevard

(Corner of Adams & Western Ave.)

Los Angeles, California

Wonderful food prepared by chef Arthur Dispirito
Including cars from the Imperial Palace Auto Collection
Entertainment for children by Astro Jump

\$7.50 PER PERSON IN ADVANCE (Tickets will be held at the door)

\$10.00 PER PERSON AT THE DOOR...CHILDREN FREE

(Includes food, beer, wine, soft drinks and dessert and valet parking)

ITALIAN PICNIC & CLASSIC CAR SHOW

ENCLOSED IS \$ _____ For _____ TICKETS TO BE HELD AT THE DOOR

UNDER THE NAME OF _____

I CANNOT ATTEND. ENCLOSED IS MY DONATION FOR \$ _____

MAKE CHECKS PAYABLE TO: **THE HELPERS' CLUB**

MAIL TO:

DEVELOPMENT OFFICE

ST. JOHN OF GOD RETIREMENT AND CARE CENTER

2035 WEST ADAMS BOULEVARD

LOS ANGELES, CA 90018

REPRODUCTION PARTS SOURCE LIST

FORD OBSOLETE PARTS
2126 Floyd St.
Burbank, CA. 91504
(818) 982-5303 / 295-2685

JOBLot AUTOMOTIVE, INC.
FORD PARTS SPECIALISTS
98-11 211th Street
Queens Village, L.I., New York 11429
(718) 468-8585/FAX:468-8686

C.W. MOSS AUTO PARTS
967 E. Mission Blvd.
Pomona, CA. 91766
(909) 629-5223
FAX: (909) 620-5642

C.W. MOSS AUTO PARTS
402 W. Chapman Ave.
Orange, CA. 92666
(714) 639-3083
FAX: (714) 639-0329

PATRICK'S
P.O. BOX 10648
Casa Grande, AZ. 85230
(602) 836-1117

OLD FORD PARTS
35 - 4th Avenue N.
Algona, WA. 98001
(206) 833-8494

SOUTHSIDE OBSOLETE
6819 James Avenue South
Minneapolis, Min. 55423
(612) 866-1230

FORD OBSOLETE
639 Gelankler St.
Memphis, Tennessee 38112
(901) 323-2179

"Otto Mechanic"

By Jay Piersanti

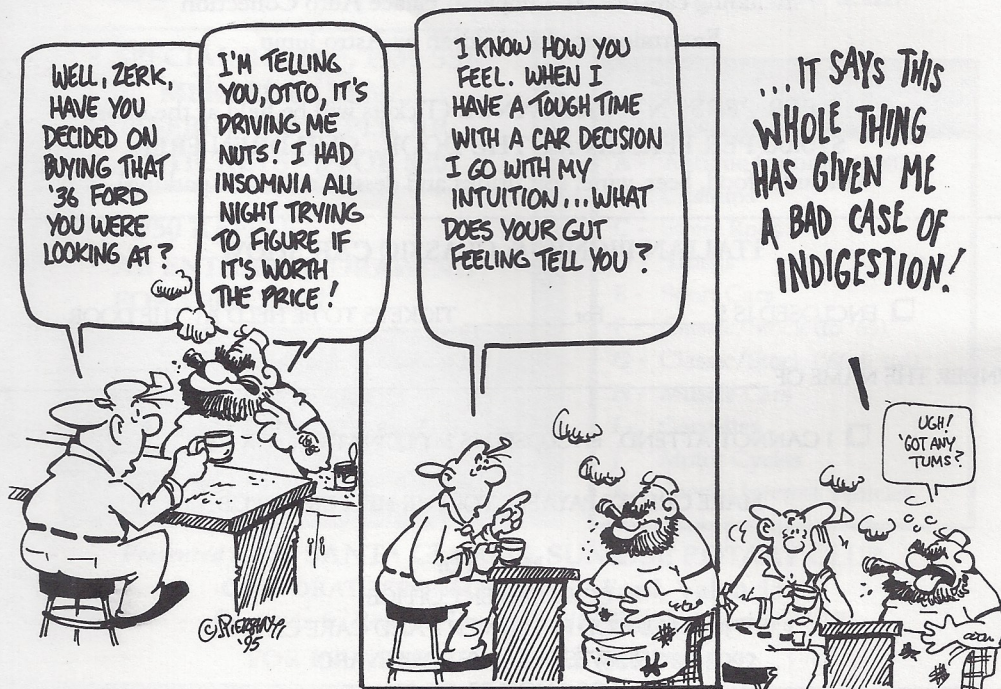

SUPPORT OUR ADVERTISERS!



INCENTIVE CONNECTION TRAVEL

1940 E. Thunderbird Rd.
Suite 105
Phoenix, AZ 85022
(602) 867-9606

Travel Agent
Beverly Dupr e
(818) 883-2747

FLIP SMITH



7735 SEPULVEDA BOULEVARD
VAN NUYS, CALIFORNIA 91405
Bus: (818) 786-8686
Fax: (818) 785-2982

DON'S Auto Parts

MACHINE SHOP and BALANCING

Monday thru Friday 8 a.m. to 7 p.m.
Saturday 9 to 6 - Sunday 10 to 4

10241 Woodley (At Devonshire)

Domestic &
Foreign

Parts & Supplies



(818)
894-6441

Sepulveda, CA 91343

RAFFLE PRIZE DONOR

LESLEY A. LITTNER

(818) 597-9016 / FAX:597-9145

BOOKKEEPING & BUSINESS SERVICES

5051 BLACKPOOL AVE.
AGOURA, CA. 91301



Older Cars
A Specialty

4 x 4's and
Motorhomes

Russell Sylvis, Inc.

Transmissions
Repaired • Rebuilt

(805) 527-4387

4657 Barnard St.
Simi Valley, CA

R.C. Smith's Roofing Solutions

Roofing & Waterproofing • Complete Maintenance Service

8707-D Lindley Ave., Ste. 199, Northridge, CA 91325
Lic. #356650 (818) 718-2313

Auto • Homeowners

- ANTIQUE CARS -

ED HARDIN INSURANCE

Business • Life • Health • Aircraft



Call us for your Insurance needs!

(818) 363-7864

ALLAN FRANKLIN'S BATTERY TENDER

\$59.99

club members
\$54.99

Charges battery up and turns itself off
automatically when it fully charged.

Takes the guess work out of battery maintenance!

(818) 842-2230

6, 8, or 12 Volt Models

SUPPORT OUR ADVERTISERS!

L.T. "LEE" SAWYER, INC.

Jobber

Shell Oil and Chemical Products

14117 Aetna Street, Box 369

Van Nuys, California 91408

TOM SAWYER (818) 786-8180 / (818) 785-0902

RAFFLE PRIZE DONOR



(818) 776-3290
FAX (818) 776-3291

TERRY Sash & Door

6057 Reseda Boulevard, Tarzana, CA 91356

"Able to service all your Sash & Door needs"

New Owner! New Location!

Ford Obsolete Parts

Your Local Source for NEW, USED & REPRODUCTION PARTS



Vintage & Classic

Car & Truck



1909-27 "T" • 1928-31 "A" • 1932-53 V8

Friendly, Helpful Service — 10% Discount To Club Members

Phone **818-982-5303** or **818-295-2685**

8:30 am - 6:00 pm Mon - Fri

9:00 am - 3:00 pm Sat

2126 Floyd Street, Burbank, CA 91504

RESIDENTIAL • COMMERCIAL • INVESTMENT



Spencer Realty

3948 Goodland Ave.

Studio City, CA 91604

Office: 818-761-1754

Fax: 818-761-7952



AL SPENCER

QUALITY PROFESSIONAL SERVICE

'41 Ford wins



Los Angeles mayor Richard Riorden presents "Coolest Car in Show" award to William Nolan during the Gilmore Heritage Auto Show, held at the Farmers Market.

The Valley  *'s*

5051 BLACKPOOL AVE., AGOURA, CA 91301

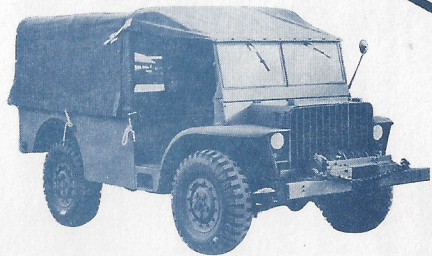
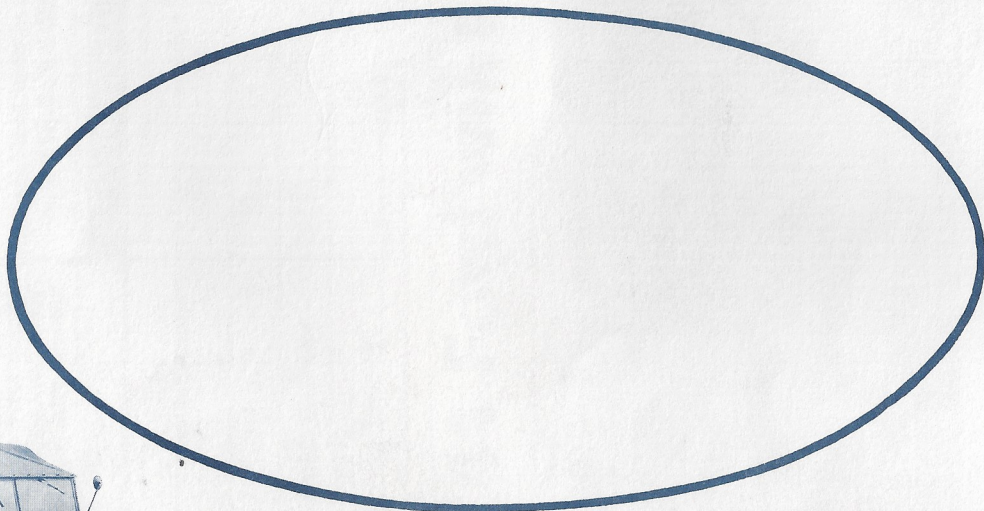

1945 Ford Cargo Truck