

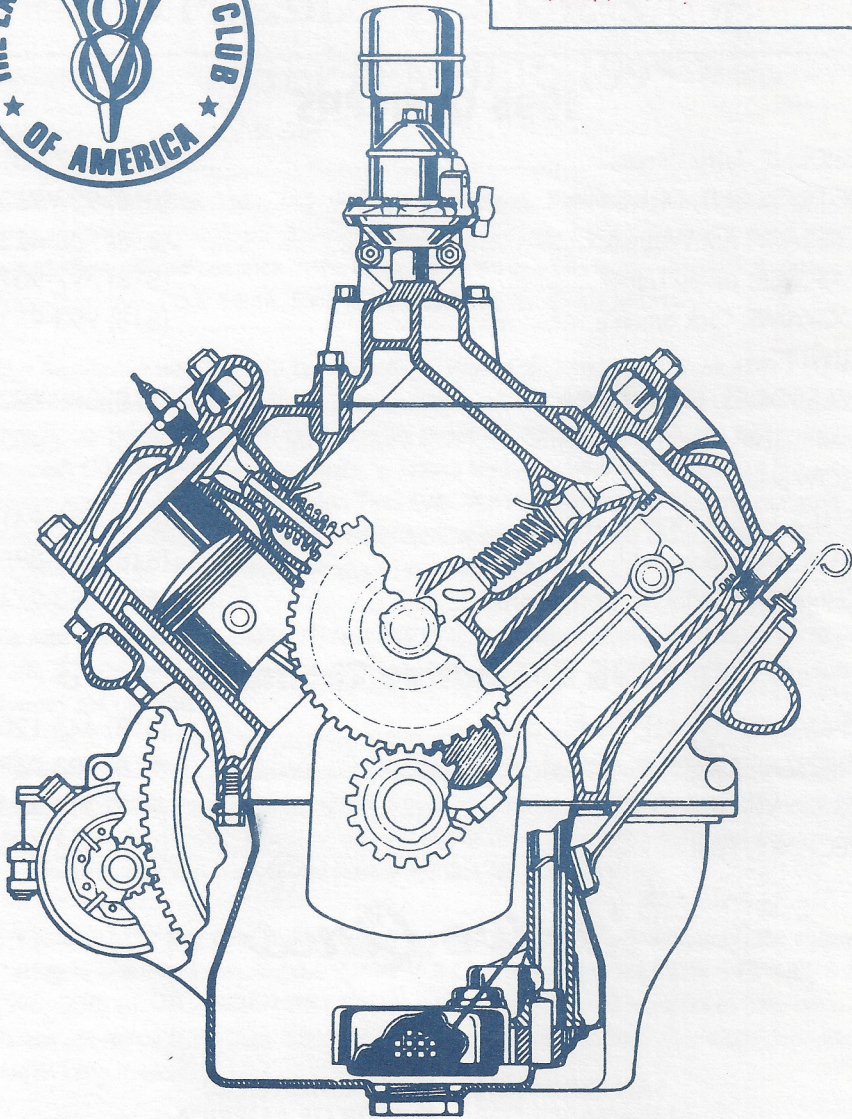

SEPTEMBER



Drive Lines

The Valley s

1995 OFFICERS

PRESIDENT, Jerry Littner	(818) 597-9016
VICE PRESIDENT, Dick Smith	(818) 993-9538
SECRETARY, Jim Winnett	(818) 768-4228
TREASURER, Lesley Littner.....	(818) 597-9016
PROGRAMS, Dick Smith	(818) 993-9538
ACTIVITIES	
ACCESSORIES, Chuck Shubb.....	(818) 882-2927
MEMBERSHIP, George Richards.....	(818) 992-4537
FELLOWSHIP	
RAFFLES, Chuck Mair	(818) 785-9413
EDITOR, Miles Schofield.....	(818) 342-8881
TECHNICAL ADVISOR, Don Dupree.....	(818) 883-2747

1995 Committee Chairmen

ANNUAL PEPPERMILL, Dudley Ochsner.....	(818) 446-1206
CHRISTMAS PARTY, Dick Smith	(818) 993-9538
TEQUILA WILLIE'S, Bob Rose.....	(818) 362-4842
DIRECTORY, Paul Kirk.....	(818) 886-5467

Drive Lines

Published By

SAN FERNANDO VALLEY CHAPTER 40
of the EARLY FORD V8 CLUB OF AMERICA

P.O. Box 96
Reseda, CA 91335

COVER/ROY JONES

The Valley V8's

PRESIDENT'S MESSAGE

SEPTEMBER, 1995

GREETINGS VALLEY V-8ers:

Our August meeting was a little different than usual. For those of you who didn't attend - it was more of a cruiser car show night than a meeting. I think we had a good time and got to show off our beauties to the other car clubs in attendance. Thanks go out to our Vice-President, Dick Smith, for a great event and for all his efforts.

Our September meeting will be held on the 10th of September - a week after Labor Day weekend. It will be at our usual meeting location. We will be treated to talks by club members. Ben DiFatta will share stories about his 40 years working at Lockheed Aircraft Co. We will also hear from Whitney Rydbeck who will talk about his acting career and the way he acquired his Taxi Cab. We look forward to hearing our club members' experiences in the real world and, would like to hear from other V-8ers at future meetings. Please don't be shy. I am waiting to INK YOU IN !

Be sure and mail your PEPPERMILL BRUNCH checks to Dudley Ochsner by September 12th. Judging and awards are done by the ladies and this always proves to be a fun Sunday get-together.

Our Christmas Party is scheduled for Sunday, December 3rd. We have booked the Smoke House Restaurant in beautiful downtown Burbank. Please see the flyer in this Drive Lines for details. It will be an evening of dining and festivities and awards. Be sure to join your V-8 friends and family for this special party.

It's getting to be that time of year when the kids are going back to school, the summer touring is winding down and the Valley V-8 Club is looking for NEW OFFICERS for the 1996 - 25th CLUB ANNIVERSARY YEAR! It takes very little effort to help out a lot. Please see me or V.P., Dick Smith to volunteer for any position. Our Club depends on you to keep it great.

Name badges are currently being ordered and will be available soon. All new members are entitled to a badge at no charge. I will let you know when they are in.

For those of you who are just a little bit curious... the engine is back in my '40 and I hope to have the car at our September meeting. Happy trails...

Your Prez. Jerry

Program for Sunday, September 10th, will be held at the
GLENDALE FEDERAL SAVINGS
21821 DEVONSHIRE, CHATSWORTH

TIRE KICKING: 7: P.M.

MEETING: 7:30 P.M.

WE'RE BACK AT OUR REGULAR MEETING SPOT!

Bring your classic and come listen to **BEN DiFATTA** speaking about stories and photos he has taken in the past 40 years.

And another special speaker... **WHITNEY RYDBECK** who will speak about his acting career and the way and why he purchased his Ford Taxicabs!

GET WELL DEPARTMENT...

Jerry Jensen is recuperating from his appendix attack.
Give him a call or send a note.

P A R T S W A N T E D

Sunvisor and grille guard with stiffeners, for '40 Ford convertible.

Richard Valleroy

310-828-7276

VICE PRESIDENT'S VIEWPOINT

The meeting of August 6, 1995 was an idea I had that didn't seem to work out as planned. I had been looking for a meeting place for the club in a restaurant - so that a greater number of our spouses would come to our meeting and have a good time. Well, the restaurants didn't want to cooperate. So I went to CRUISERS' CAR WASH. The manager agreed to stay open for us at no additional charge or guarantee of how much we would spend. Not wanting a small turn-out, and thinking it would be nice for the car wash, and being a cruiser myself, I thought I'd pass out flyers to other cruisers on Friday, Saturday and Sunday nights (to Ford owners only). Well you know how that goes. We had more Rodfathers and others than we had club members. I would like to thank all of our members who did show up.

The evening started out a warm August night. So much for the good times. For starters our President and First Lady, Jerry and Lesley were late due to a breakdown of their 1937 Ford on the freeway. They had a neighbor/friend who said he would follow them in case of trouble but he broke down also. He was driving a '64 Corvette when last was seen. He never made it due to a fire that ate up all the wiring.

We had a Ladies' raffle with four winners. (Sorry but I didn't get the names.) I would like to thank Lesley Littner for her time and effort in baking the ladies gifts. We had our regular raffle and then the Odometer Trophy Awards. The winners of the trophies - for the closest odometer reading to "274" high and low were: Chuck Shubb with his 1931 Ford and George Howard won low with his '55 T-Bird. Some of the cars that were driven to Cruisers were: (3) 1923 T-Buckets, 1926 & 1927 Roadsters, (2) 1931 Roadsters, 1936 Roadster, 1936 Cabriolet, 1939 Convertible, (5) 1940 Convertibles, coupes, Fordoors & a Pickup, 1941 Coupe, 1948 Lincoln Cont., 1950 Fordoor, 1953 Coupe, a 1955, 1957 & 1963 T-Birds, 1957 Ford Retractable, 1966 Satellite (Hemi), & a 1972 Chevelle.

I would like to apologize to Ben DiFatta. He was scheduled as our speaker of the evening but, without a P.A. system he would never have been heard. We are looking forward to hearing from you at our September meeting.

Two cars would not start at the end of the night due to dead batteries - Don Stout's '56 Chevy and Patti Smith's 1931 Roadster (which she drove herself). So the August 6th meeting is over and I'm not planning any more activities for a few months. Patti and I are looking forward to August 15th - the day we head north on the Jay Harris tour to Bend, Oregon and the Western National Meet. Hope to see you all at the September meeting.

Respectfully,
Dick Smith

Tickets will be held at the door and can be picked up after 9:30 a.m.



**SEPTEMBER
V-8 BIRTHDAYS**

9/06 SUZANNE CASE

9/07 TOMY THOMPSON

9/11 PATTI SMITH

9/13 ANN CAPLAN

9/15 MARTIN LUENING

9/16 BARBARA SIMPSON

9/18 DICK SMITH

9/20 BOB McCULLAGH

9/23 MARK HENZEL

9/26 HARRIET KAWELMACHER

9/28 BILL CARPENTER

9/28 DIANN CHAMBERLIN

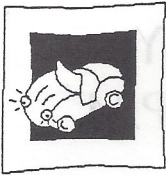

EARLY FORD V-8 CLUB OF AMERICA
VALLEY V-8'S HOST

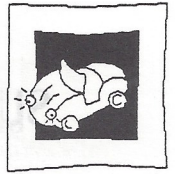

**TENTH ANNUAL
PEPPERMILL BRUNCH 1995**
Pasadena, California 91101

Baldy View	\$9.75 Per Person	Best of Show
Ventura	September 17, 1995	Ladies Awards
Southern Cal	Tire Kicking 9:30 a.m.	Prizes
San Diego	Doors Open 10:00 a.m.	Awards
Lincoln Club	Brunch served promptly at 10:30 a.m.	Fun
Central Coast		

RSVP by September 12, 1995

Make and mail checks to:

Dudley C. Ochsner
750 East Green Street, Suite 302
Pasadena, CA 91101
(818) 793-5104

Yes I will attend Peppermill 1995 on September 17th!

I have enclosed my check in the amount of \$ _____ for _____ people.

Name _____ Regional Group _____

Phone _____

Tickets will be held at the door and can be picked up after 9:30 a.m.!

1995 ANNUAL CHRISTMAS PARTY
SUNDAY, DECEMBER 3RD - 6:00 P.M.

THE SMOKE HOUSE RESTAURANT

4420 LAKESIDE DRIVE
BURBANK, CA. 91505

MENU SELECTIONS:

- >PRIME RIB OF BEEF
- >BROILED ORANGE ROUGHY
- >CHICKEN TERIYAKI SERVED OVER RICE

DINNERS SERVED WITH SALAD, VEGGIES,
POTATO/RICE, DESSERT & COFFEE OR TEA.

.....\$25.00 PER PERSON.....

ENCLOSE YOUR CHECK PAYABLE TO: VALLEY V-8 CLUB

NAME(S): _____

\$25.00 EACH PERSON...TOTAL ENCLOSED: \$ _____

ENTREE CHOICE(S):PRIME RIB _____ CHICKEN _____ FISH _____

SEND CHECKS TO: VALLEY V-8 CLUB
C/O LESLEY LITTNER

5051 BLACKPOOL AVENUE, AGOURA, CA. 91301 (818) 597-9016

RESERVATION CHECKS MUST BE RECEIVED BY: NOVEMBER 24TH !



TRIVIA QUIZ

..by Ralph (again) Hubbard

1. What year did Ford use a Chandler Groves carburetor on a Ford V-8 engine?
A. 1937 B. 1938 C. 1939 D. 1940
2. What year did Ford move the battery into the engine compartment?
A. 1935 B. 1936 C. 1937 D. 1938
3. What year did Ford V-8 introduce a fuel pump with a glass jar fuel filter?
A. 1945 B. 1946 C. 1947 D. 1948
4. Which of the following cars first introduced an engine with 4 valves per cylinder?
A. Toyota B. Studebaker C. Ford D. Duesenberg E. Edsel
5. When did Ford first move or install the coil away from the distributor on a flathead V-8?
A. 1949 B. 1946 C. 1942 D. 1941 E. None of above
6. What year did Ford first introduce a "Hot Water" type heater as a factory authorized accessory?
A. 1936 B. 1938 C. 1939 D. 1941 E. 1937
7. What year was the last year that a Ford V-8 had a "Butler Finish" or nickel plate on a piece of interior hardware?
A. 1934 B. 1936 C. 1938 D. 1939
8. John Dahlinger states in a book that he is one of the following?
A. The son of Henry Ford B. The designer of the Ford flathead V-8 engine C. The designer of the camshaft "Direct Drive" Ford V-8 distributor D. Clara Ford's secret lover E. Founder of the early Ford V-8 Club of America

Answers next page - Don't peek!!!

Good Formula

When the late Mr. and Mrs. Henry Ford celebrated their golden wedding anniversary, a reporter asked them: "To what do you attribute your fifty years of successful married life?"

"The formula," said Ford, "is the same formula I have always used in making cars—just stick to one model."

ANSWERS

1. B - 1938
2. C - 1937
3. C - 1947
4. D - Duesenberg
5. C - 1942
6. C - 1939
7. B - 1936
8. A - "The Son"

Thanks Ralph for the Trivia Questions

*Excerpt from a letter
received from*

Tomy (way up north) **Thompson...**

**THE IRISH - Be they Kings
or Poets or Farmers, they're
people of great worth,
...they keep company with
angels and bring a bit of
heaven to earth!!**

SCV *S*UNRISE *R*OTARY CAR *S*HOW AND *H*ISTORICAL *P*OKER *R*UN

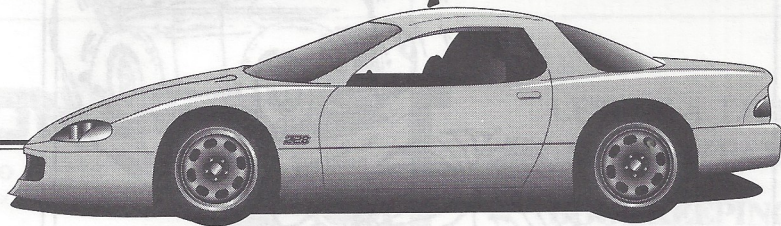

at

Santa Clarita Metrolink Station

(Soledad Canyon Road, East of Saugus Speedway)

Saturday, September 16, 1995

6 a.m. – 12 Noon

REGISTRATION: 6:00 a.m. to 9:00 a.m.

- SPECIAL RAFFLE, 1939 SSK
MERCEDES BENZ,
FIBERGLASS REPLICAR
\$5 TICKETS - 5 FOR \$20

- 50/50 RAFFLE
- ALL ENTRANTS DRAWING
FOR \$500 CASH

Schedule of Events

- 6 a.m. Gates Open
9 – 11 a.m. Judging by Participants
(not own class)
11:00 a.m. Awards Presentation
11:45 a.m. Poker Run Begins (\$5 Entry)

Classes

- A - Antique (prior to 1930)
- B - Customs
- C - Street Rods
- D - Trucks
- E - Sport Cars
- F - Classic/Stock (to '65)
- G - Classic/Stock ('66 & up)
- H - Muscle Cars
- I - Corvettes
- J - Motor Cycles
- K - Special Interest Vehicles

Presented by the SANTA CLARITA SUNRISE ROTARY CLUB

CORPORATE SPONSOR, Magic Ford, Valencia

Proceeds to Benefit Santa Clarita Valley Charities

FOR INFORMATION CALL (805) 789-5092

Love is...



Kris

*... making me think more
about you than me.*

Presented by the SANTA CLARITA SUNRISE ROTARY CLUB
CORPORATE SPONSOR Magic Event, Valencia
Proceeds to benefit Santa Clarita Valley Children
FOR INFORMATION CALL (805) 789-5092

SUPPORT OUR ADVERTISERS!



INCENTIVE CONNECTION TRAVEL

1940 E. Thunderbird Rd.
Suite 105
Phoenix, AZ 85022
(602) 867-9606

Travel Agent
Beverly Dupr e
(818) 883-2747

FLIP SMITH



7735 SEPULVEDA BOULEVARD
VAN NUYS, CALIFORNIA 91405

Bus: (818) 786-8686
Fax: (818) 785-2982

DON'S Auto Parts

MACHINE SHOP and BALANCING

Monday thru Friday 8 a.m. to 7 p.m.
Saturday 9 to 6 - Sunday 10 to 4

10241 Woodley (At Devonshire)

Domestic &
Foreign
Parts & Supplies



(818)
894-6441

Sepulveda, CA 91343

RAFFLE PRIZE DONOR

LESLEY A. LITTNER
(818) 597-9016 / FAX: 597-9145

BOOKKEEPING & BUSINESS SERVICES

5051 BLACKPOOL AVE.
AGOURA, CA. 91301



Older Cars
A Specialty

4 x 4's and
Motorhomes

Russell Sylvis, Inc.
Transmissions
Repaired • Rebuilt

(805) 527-4387

4657 Barnard St.
Simi Valley, CA

R.C. Smith's Roofing Solutions

Roofing & Waterproofing • Complete Maintenance Service

8707-D Lindley Ave., Ste. 199, Northridge, CA 91325
Lic. #356650 (818) 718-2313

Auto • Homeowners

- ANTIQUE CARS -

ED HARDIN INSURANCE

Business • Life • Health • Aircraft



Call us for your Insurance needs!

(818) 363-7864

ALLAN FRANKLIN'S BATTERY TENDER

\$59.99

club members
\$54.99

Charges battery up and turns itself off
automatically when it fully charged.
Takes the guess work out of battery maintenance!

(818) 842-2230

6, 8, or 12 Volt Models

PAST PRESIDENTS

JIM ROWE.....	1971
DOUG PETERSON	1972
DON DURKEE	1974
ED WARNOCK	1975
JOHN BUSK.....	1976
CHIP WERSTEIN	1977
STAN MARSRAJE	1978
BOB DRAKE	1979
BILL CULP.....	1979
AL SPENCER.....	1980
LARRY CAPLAN	1981
BOB ROSE	1982
DON DURKEE	1983
PAUL KIRK	1984
KENT LOWRY	1985
DAVE SANBORN.....	1986
JOHN KEMMERER	1987
DUDLEY OCHSNER.....	1988
JERRY JENSEN	1989
JERRY JENSEN	1990
JOE DiFATTA	1991
CHUCK SHUBB.....	1992
CHUCK SHUBB.....	1993
GEORGE RICHARDS	1994

Meetings are held on the first Sunday of every month at 7:00 p.m.

The Valley  **'s**

5051 BLACKPOOL AVE., AGOURA, CA 91301

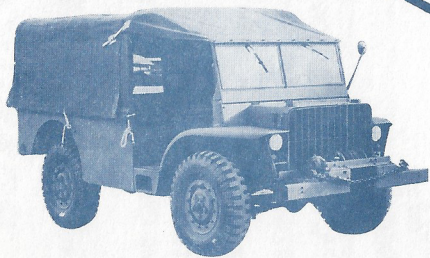
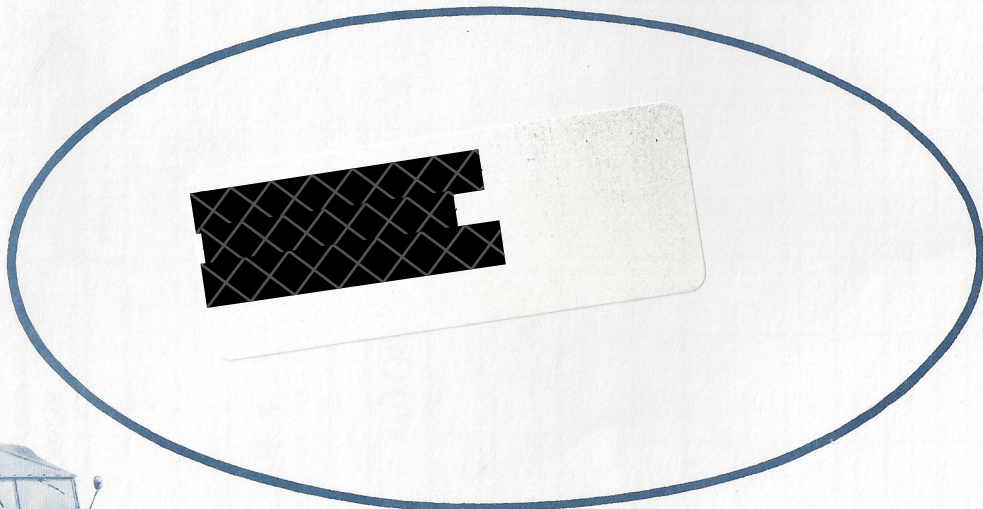

1945 Ford Cargo Truck