

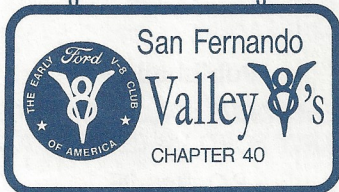

FEBRUARY

Our 25th Year

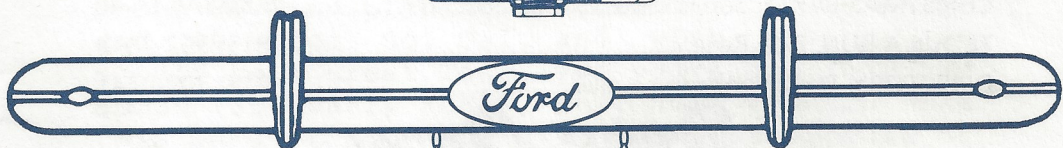
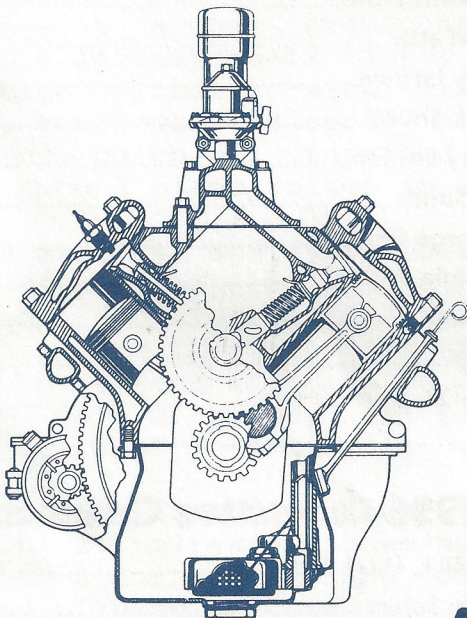

Drive Lines

The Valley s

1996 OFFICERS

PRESIDENT, Dick Smith.....	(818) 368-5890
VICE PRESIDENT, John Wolf.....	(818) 789-6201
SECRETARY, Joe DiFatta.....	(818) 700-1939
TREASURER, Lesley Littner.....	(818) 597-9016
PROGRAMS, Chuck Shubb.....	(818) 882-2927
ACCESSORIES, Jerry Littner.....	(818) 597-9016
HISTORIAN, Patti Smith.....	(818) 368-5890
MEMBERSHIP, George Richards.....	(818) 992-4537
FELLOWSHIP, Virginia Wolf.....	(818) 789-6201
RAFFLES, Chuck Mair.....	(818) 785-9413
EDITOR, Don Stout.....	(818) 998-7054
TECHNICAL ADVISOR, Don Durkee.....	(805) 495-5298
TOUR MASTER.....	EVERYONE

1996 Committee Chairmen

ANNUAL PEPPERMILL, Dave Sanborn.....	(818) 709-0741
CHRISTMAS PARTY, Santa Claus.....	(800) SANTA 40
TEQUILA RUN, Bob Rose.....	(818) 362-4842
DIRECTORY, Dave Sanborn.....	(818) 709-0741

Drive Lines

Published By

SAN FERNANDO VALLEY CHAPTER 40
of the EARLY FORD V8 CLUB OF AMERICA

P.O. Box 96
Reseda, CA 91335

The Valley V8's PRESIDENT'S MESSAGE

February 1996

THE VALLEY V8'S 25TH ANNIVERSARY YEAR

Hello Fellow Club Members:

We had 10 ladies and 28 guys, all member, show up for the January meeting. The ladies all received earrings as a door prize, and were the judges for the January meets trophy, which was won by George Richards with his 1939 Ford convertible, there were 14 early FORDS driven to the meeting, which all received points for the first & second place Prizes in November.

We voted and made Jay and Sylvia Harris honorary members of our chapter, we also voted to change our meeting night to the first Tuesday of each month. The first meeting will be held at Weilders Restaurant in North Hills. We will continue to have a trophy at each meeting through the month of November.

The Tour to C&G in Escondido looks to be shaping up, with 21 already signed-up. I called Gail at C&G this morning and she told me that about 90 were planing on coming from San Diego, and 60 from So. Cal. and with Ventura it should be a great Tour. Two years ago they had about 135 early FORDS, sure hope you can make this one, it's on the 24th of February rain or shine, BBQ chicken, drinks, etc. plus 10 per cent off on any items purchase from C&G that day.

The schedule "LOOKING AHEAD" that was printed in January Driveline was just preliminary dates to give you a idea of up and coming events, the actual scheduled dates will be printed 2 months in advance in each Driveline.

Yours Truly,

Dick Smith

***Meetings Now
On Tuesdays***

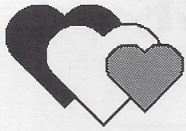

Tuesday, February 6, 1996

MEETING



New Location & Night of the Week

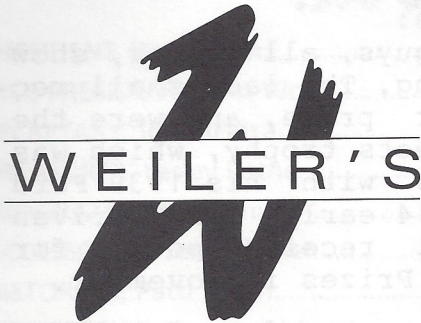

Weiler's New York Style Deli
Restaurant • Bakery • Catering
16150 Nordhoff Street
North Hills, CA
 (818) 892-8663 • Fax (818) 894-2443

6:30 PM Parking Lot Tire Kicking & Visiting & Dinner if you want, the food is good!
 7:30 PM MEETING STARTS

Two ladies in attendance will receive a door prize. Valentine Surprises for the ladies.

The Trophy for the February Meeting will be given to a early FORD 1932-53 product in the parking lot, to be chosen by a drawing, so bring your classics.

The name badge drawing (JACKPOT \$20.00), to be given to a club member in attendance that is wearing their badge.

Early FORD's driven to any Meeting, Tour, or Events will receive points, so that at the November Meeting, the member who has the most points will WIN \$100.00, and 2nd place will WIN \$50.00. UPDATE, 14 cars tied for the lead.

PROGRAM FOR THE EVENING

Our speaker for the evening is RAY LUPOLI who tells us the humorous side of restoring his Now Beautiful '35 FORD.

I'm looking forward to seeing you at the meeting on the 6th of February.

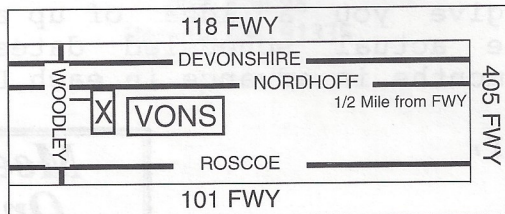



GENERAL MEETING NOTES



By Henry J. DeSoto

Big turnout of members & ladies for our Jan. 7th meeting. Our new President DICK SMITH got us started at 7:35 and proceeded with introducing our newest members: DAVID GOTT, WAYNE BURNS and BOB REED. To date we have 48 paid members and a treasury balance of approx. \$1300.00.

DICK presented special awards to JERRY & LESLEY LITTNER for their participation with the Drive Lines. Also, JOHN KEMMERER, was given a past president plaque for the year of 1987!! DICK also reminded us that this is our Club's 25th year.(We even had a Cake to Celebrate!)

There was a motion made and seconded to have our meetings on the first Tuesday of the month, it was discussed and approved. **Our first Tuesday meeting on Feb. 6th will be held at Weiler's Deli, 16150 Nordhoff in North Hills** (1 mile west of the 405 Freeway). Arrive and have dinner or snack at 6:30 or whatever time. The restaurant will be ours after 7pm. The General Meeting will start at 7:30p.m. There will be 20 - 25 parking spots for our classics. Please park other cars in the next row.

After coffee and 25th anniversary cake break, we had the ladies give us their results on the best looking FORD in the Parking Lot. The winner was GEORGE RICHARDS' - '39 Convertible.

CHUCK MAIR proceeded with our general raffle. Lots of winners ... Thanks to TOM SAWYER for the Shell Oil, DON'S AUTO PARTS and DICK and PATTI SMITH for their lovely basket of goodies (won by JACK MILES). The New "Yellow Ticket" winner was VIRGINIA WOLF ... \$20.00

DENNIS KEENE was our speaker, and gave us highlights of the beginning of the Ford Clubs in So. California. Three Chapters started in the late 60's and early 70's. His personal story of the FORDs in his life, including a '34 Coupe, '41 Tudor and '46 Coupe. Even a '51 Merc that he traded a brother-in-law for a second '46 Coupe. In 1967 he purchased a '32 Coupe and somewhere in this era bought a '40 Coupe. Also spoke about his '47 4-door made into a police car with holes drilled on top and fenders for red lights & siren ... "Promised Lights & Siren" ... but didn't get them. His police car was in the movie "Two Jakes". He even got an autograph of Jack Nicholson!!! A great story ... Thanks, DENNIS for your life story.

We also received Christmas Thank You's for our donation of toys from the Catholic Charities and the MEND programs.

*"Our Kids are Our Investments . . .
Our Grandkids are the Dividends"*

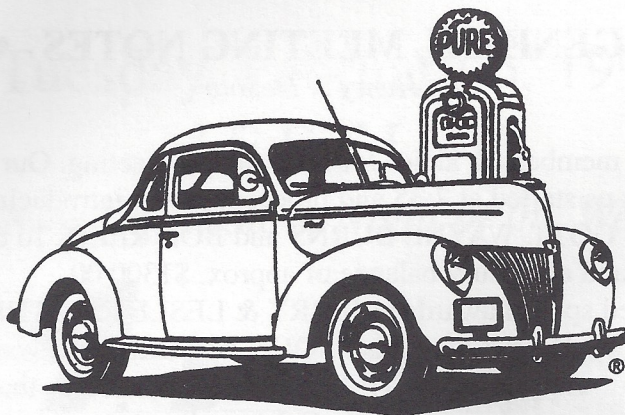

EARLY V8 FORDS DRIVEN TO THE MEETING

- 1939 Ford Convertible – George Richards
- 1940 Ford Tudor – Jerry & Lesley Littner
- 1953 Ford Coupe – Lloyd & Donna Paschal
- 1951 Lincoln Cos. Mo. – Cal & Nancy Beauregard
- 1940 Ford Pick Up – David & Rose Gott
- 1932 Ford Roadster – Richard Stone
- 1940 Ford 4 Door – Al Rohrer
- 1942 Ford 4 Door – Wayne Burns
- 1939 Ford Convertible – Richard Chutuk
- 1953 Mercury Hard Top – Don Durkee
- 1948 Ford Coupe – Lin & John Kemmerer
- 1940 Ford Tudor – John & Virginia Wolf
- 1940 Ford Coupe – Dick & Patti Smith

All of the above cars have one point towards the November JACKPOT.

CARS & PARTS FOR SALE

'32 Shell & 3 piece hood with brackets from Model A Street Rod
\$350.00 Wayne Burns (818) 368-9028

'72 Chevell 2-door CLEAN 350X350 posi.
\$7,000.00 Lee Wright (818) 846-4906

'88 Corvette
\$10,500.00 Bob Reed (818) 346-5685

'89 Car Trailer
\$2,000.00 Harold Fredrickson (818) 882-9253

FEBRUARY TOUR

The Tour to C&G in Escondido, on Saturday, February 24th is leaving from Woodley Park at 8:30 AM, it's a BBQ, not a pot luck, you need not bring anything, there is going to be a \$3.00 charge per person for food and drinks. If you want to go, please sign-up at our February Meeting, or contact Dick Smith at (818) 368-5890 before February 18th. We're expecting a big turnout and a beautiful Tour Day.

C & G is offering all Valley V8ers, a 10% discount on all parts purchased OR ordered by phone on Saturday, February 24th.

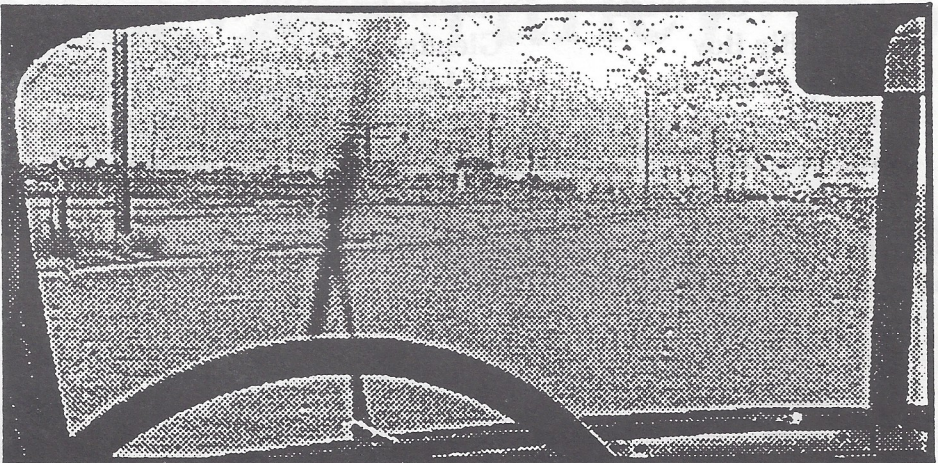

“LOOKING AHEAD”

FEBRUARY —

6:30 PM, Tuesday, February 6, 1996, Meeting at Weiler's Deli.

8:30 AM, Saturday, February 24, 1996, meet at Woodley Park, Tour to C&G in Escondido, Fun and BBQ.

MARCH —

6:30 PM, Tuesday, March 5, 1996, Meeting at Weiler's Deli.

9:00 AM, Sunday, March 31, 1996, Meet at Woodley Park, for Wild Flowers Tour and Picnic.

Editor's Column

February is fast approaching and our planned tour to C & G is shaping up. Gail is also expecting many members from Orange County, and their San Diego Club to be joining us, a good time to see some old friends and meet new ones ... and of course see some good looking Fords.

Cruise nights in the area have been flourishing with all the summer weather, lets get some of those V8's on the road!

Bob's Big Boy

Cruiser's Car Wash

Bob's Big Boy

Teddy's Drive-In

Thousand Oaks Mall

Weiler's Deli

Toluca Lake

Northridge

Glendale

W. Los Angeles

Thousand Oaks

North Hills

Friday P.M.

Friday P.M.

Wednesday P.M.

Thursday P.M.

Sunday A.M.

Sunday P.M.

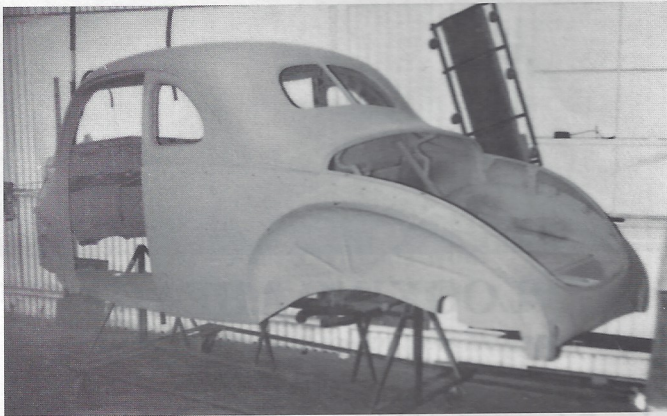

My 40 Deluxe (Five Window)) Coupe is spread all over California, the body is bead blasted and primed in Van Nuys; Engine at Dan Krehbiels in Temecula; Radiator in Reseda; and the Transmission on the way to Rus in Simi Valley. Starting a new restoration is great fun, and I have already met many fine V8 folks along the way.

I would like some input for our drive line on reference books, (I can use it myself), available for our great hobby or business, whichever it may be to you.

Don Stout

15220 Raymer St.

Van Nuys, CA 91205

Editor

Phone (818) 782-4604

FAX (818) 782-5099

Hopefully our car plaques will be at the February 6th Meeting

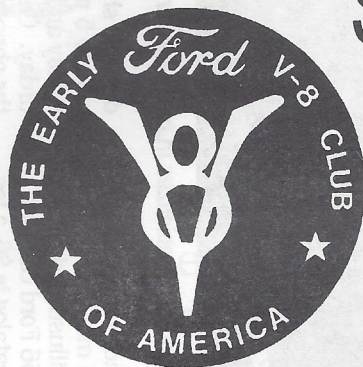

San Fernando

Valley 's

CHAPTER 40

Dues Deadline is

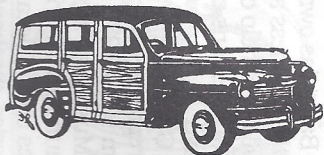

February 15th

Super Ford Jackpot

\$20.00

Could Be Yours!

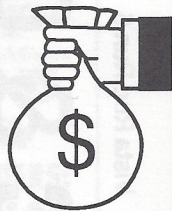

C & G team eager to offer help

C & G Early Ford Parts was originally started in Parsippany, New Jersey in 1978 by Clyde and Gail Bangiola. In 1982 they moved their business to San Marcos. Ten years later their daughter, Dorothy Bangiola, acquired the business. Dorothy has worked with the business since 1984. C & G is located at 1941 Commercial St. in Escondido where they own a 9,000 square-foot building.

Included in the staff at C & G is parts manager Kyle A. Allen, who has worked for the business for eight years and has a total of 12 years experience in the antique Ford parts field.

Allen is ready and willing to offer his assistance in answering your questions regarding availability and applicability of parts.

Allen has restored his own 1963 Falcon and is a member of the Falcon Club and Fairlane Club. Also included in our staff

is John E. Mac Queen, who is a 20-year veteran in the automotive field, is currently doing a restoration of his own car and is active in two local car clubs.

Another member of their staff is John B. Corona Jr., who has been with the company for eight years. Corona had previously worked for Heller Ford for 35 years before retiring to the C & G staff. Clyde Bangiola started his automotive career in 1957 with Ford Motor Co. and has been a mechanic all his life.

The Bangiolas own the repair end of the business and are always willing to help out with any technical questions customers may have.

C & G stocks more than 7,000 reproduction parts ranging from 1932-1970 Ford car, truck, Mustang, Falcon, Fairlane and Thunderbird. The inventory includes books, decals, chrome accessories, mechanical parts,

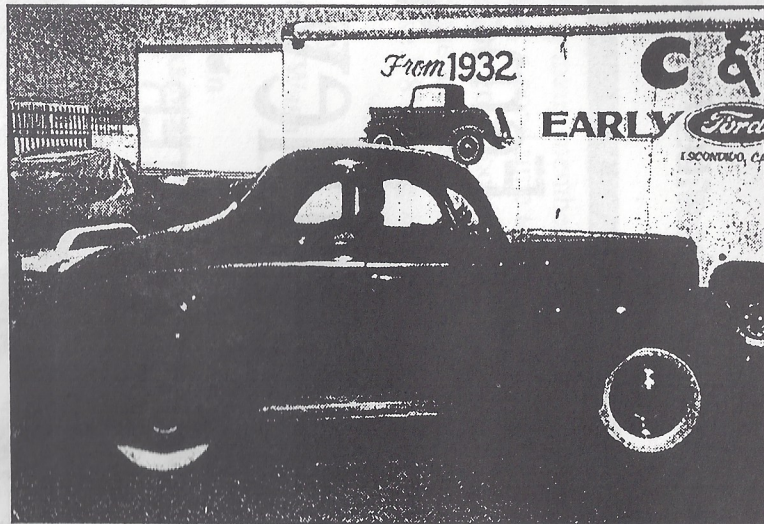

C & G in Escondido specializes in parts for early model Fords.

wiring, weather-stripping, novelty items, and much more. C & G offers a fully illustrated catalog for 1932-1956 Ford cars and trucks. The catalog is \$6, a fee which is refunded with \$100 or-

der. The shop is open from 9 a.m. to 5 p.m. Monday through Friday and 9 a.m. to 3 p.m. Saturday. Call 740-2400 or stop by the shop at 1941 Commercial St., Escondido.

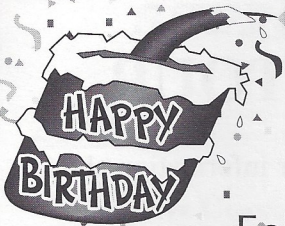

February V8 Birthdays

- Feb. 4th Marsha DiFatta
- Feb. 4th Beth MacArthur
- Feb. 11th Don Durkee
- Feb. 17th Diane Baily
- Feb. 18th Bill Scott
- Feb. 19th Lee Wright
- Feb. 21st Roger Montgomery
- Feb. 25th Joe DiFatta
- Feb. 27th Lin Kemmerer

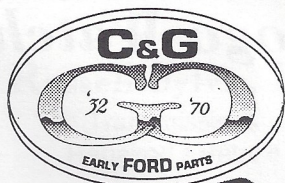

EARLY FORD PARTS

★NEW★



'28 - '48 REAR AXLE HOUSING SLEEVES

\$39⁵⁰ EA.

DEALERS WELCOME!

C&G EARLY FORD PARTS

1941 Commercial St., Dept. V

Escondido, CA 92029-1233

Mon. - Fri. 9-5 / Sat. 9-3

Info: (619) 740-2400 • 24 Hr. FAX: (619) 740-8700

Shipping and Sales Tax Extra

• ORDERS SHIPPED WITHIN 24 HOURS •
• 95% TO 98% IN STOCK •

• Authorized Dennis Carpenter Dealer • Plus 200 Other Suppliers •
• We Honor Bob Drake Sales • Reliable Service Since 1978 •

1935-36 CLOCK MIRROR

Made In U.S.A. Exclusively for "C&G"

(SECONDS ONLY)

Limited Quantity

\$75⁰⁰

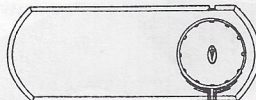

'42 - '48 RADIO FOOT CONTROL SWITCH AND HARDWARE

\$25⁰⁰



'38 - '48 WOODY SLIDING WINDOW HANDLES

STAINLESS 4 PC. SET \$55⁰⁰

'38 - '48 WOODY RAIN GUTTER CLIPS AND SCREWS
★NEW★
\$25⁰⁰



'51 - '54 VICKY ROOF SIDE EMBLEM

1A-7004539 - 1951 Dash Emblem

Reg. 225 Sale \$22⁰⁰



Catalog: '32 - '56 Pass. & Pickup 276 Pages, 5,000 + Parts
\$6.00 PPD U.S.A. - \$8.00 Foreign - Free With \$100.00 Order



FORD PARTS ORDERS:

1-619-740-2400

FORD NATIONAL BRITISH COLUMBIA TOUR

To FORD Club Members, Contact President Dick Smith for information about the Jay & Sylvia Harris Tour to British Columbia.

Starting from Palmdale on Sunday, July 28th, traveling each day through Bishop, Tahoe and Alturas, California; Redmond, Oregon; Stevenson, Chehalis and Mt. Vernon, Washington and arriving in Vancouver on Saturday. We will be boarding the ferry-boat to British, Columbia on Sunday, August 4th.

A few members from our club have already signed up for the fantastic trip.

DON'T MISS OUT!!

For more information or to RSVP (June 1st is the deadline),
please contact Jay or Sylvia Harris at:

1512 South Hill Avenue
Fallbrook, CA 92028
(619) 728-0311

Interested in a Ford Logo Watch?

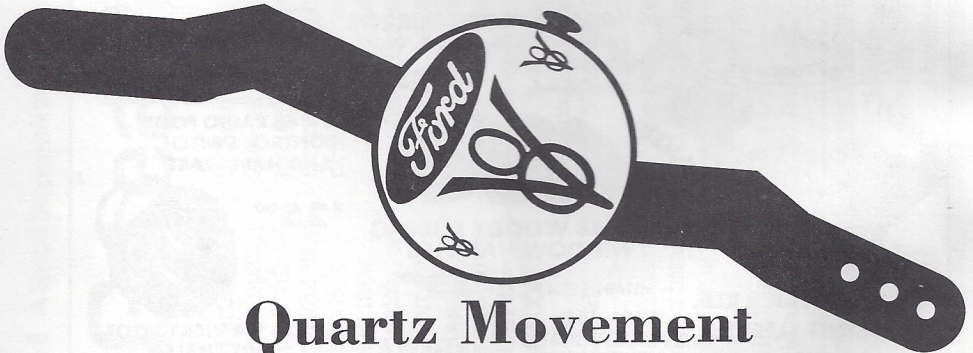

Quartz Movement

\$45.00 per watch

Contact Joe DiFatta

SUPPORT OUR ADVERTISERS!



INCENTIVE CONNECTION TRAVEL

1940 E. Thunderbird Rd.
Suite 105
Phoenix, AZ 85022
(602) 867-9606

Travel Agent
Beverly Dupr e
(818) 883-2747

FLIP SMITH



7735 SEPULVEDA BOULEVARD
VAN NUYS, CALIFORNIA 91405
Bus: (818) 786-8686
Fax: (818) 785-2982

DON'S Auto Parts

MACHINE SHOP and BALANCING

Monday thru Friday 8 a.m. to 7 p.m.
Saturday 9 to 6 - Sunday 10 to 4

10241 Woodley (At Devonshire)

RAFFLE PRIZE DONOR

Domestic &
Foreign

Parts & Supplies



(818)

894-6441

Sepulveda, CA 91343

LESLEY A. LITTNER

(818) 597-9016 / FAX:597-9145

BOOKKEEPING & BUSINESS SERVICES

5051 BLACKPOOL AVE.
AGOURA, CA. 91301



Older Cars
A Specialty

4 x 4's and
Motorhomes

Russell Sylvis, Inc.

Transmissions
Repaired • Rebuilt

(805) 527-4387

4657 Barnard St.
Simi Valley, CA

R.C. Smith's Roofing Solutions

Roofing & Waterproofing • Complete Maintenance Service

8707-D Lindley Ave., Ste. 199, Northridge, CA 91325
Lic. #356650 (818) 718-2313

Auto • Homeowners

- ANTIQUE CARS -

ED HARDIN INSURANCE

Business • Life • Health • Aircraft



Call us for your Insurance needs!

(818) 363-7864

ALLAN FRANKLIN'S BATTERY TENDER

\$59.99

club members
\$54.99

Charges battery up and turns itself off
automatically when it fully charged.

Takes the guess work out of battery maintenance!

(818) 842-2230

6, 8, or 12 Volt Models

SUPPORT OUR ADVERTISERS!

L.T. "LEE" SAWYER, INC.

Jobber

Shell Oil and Chemical Products

14117 Aetna Street, Box 369
Van Nuys, California 91408

TOM SAWYER (818) 786-8180 / (818) 785-0902

RAFFLE PRIZE DONOR



(818) 776-3290
FAX (818) 776-3291

TERRY Sash & Door

6057 Reseda Boulevard, Tarzana, CA 91356

"Able to service all your Sash & Door needs"

New Owner! New Location!

Ford Obsolete Parts

Your Local Source for NEW, USED & REPRODUCTION PARTS



Vintage & Classic

Car & Truck



1909-27 "T" • 1928-31 "A" • 1932-53 V8

Friendly, Helpful Service — 10% Discount To Club Members

Phone **818-982-5303** or **818-295-2685**

8:30 am - 6:00 pm Mon - Fri

9:00 am - 3:00 pm Sat

2126 Floyd Street, Burbank, CA 91504

RESIDENTIAL • COMMERCIAL • INVESTMENT



Spencer Realty

3948 Goodland Ave.
Studio City, CA 91604
Office: 818-761-1734
Fax: 818-761-7952



AL SPENCER

QUALITY PROFESSIONAL SERVICE

OPEN EVENT . . . ALL VEHICLES

WELCOME!!

14th Annual Car Show

Presented by: Classic Chevs of So. California
For Information Call: Alan Donath (818) 222-8340 or
David Helman (818) 881-9356

Location: Blue Cross of California Facility
21555 Oxnard Street, Woodland Hills
Plenty of Green Lawn and Shade

May 5th, 1996

Rain Date May 19th

Registration
8:00 a.m. to 11 a.m.

PAST PRESIDENTS

JIM ROWE.....	1971
DOUG PETERSON.....	1972
DON DURKEE.....	1974
ED WARNOCK.....	1975
JOHN BUSK.....	1976
CHIP WERSTEIN.....	1977
STAN MARSRAJE.....	1978
BOB DRAKE.....	1979
BILL CULP.....	1979
AL SPENCER.....	1980
LARRY CAPLAN.....	1981
BOB ROSE.....	1982
DON DURKEE.....	1983
PAUL KIRK.....	1984
KENT LOWRY.....	1985
DAVE SANBORN.....	1986
JOHN KEMMERER.....	1987
DUDLEY OCHSNER.....	1988
JERRY JENSEN.....	1989
JERRY JENSEN.....	1990
JOE DiFATTA.....	1991
CHUCK SHUBB.....	1992
CHUCK SHUBB.....	1993
GEORGE RICHARDS.....	1994
JERRY LITTNER.....	1995

Meetings are held on the first Sunday of every month at 7:00 p.m.

The Valley s

10532 GERALD AVE., GRANADA HILLS, CA 91325

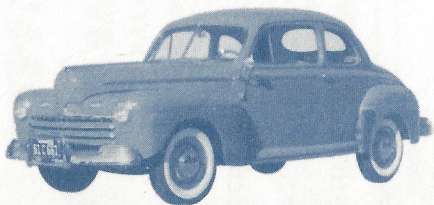
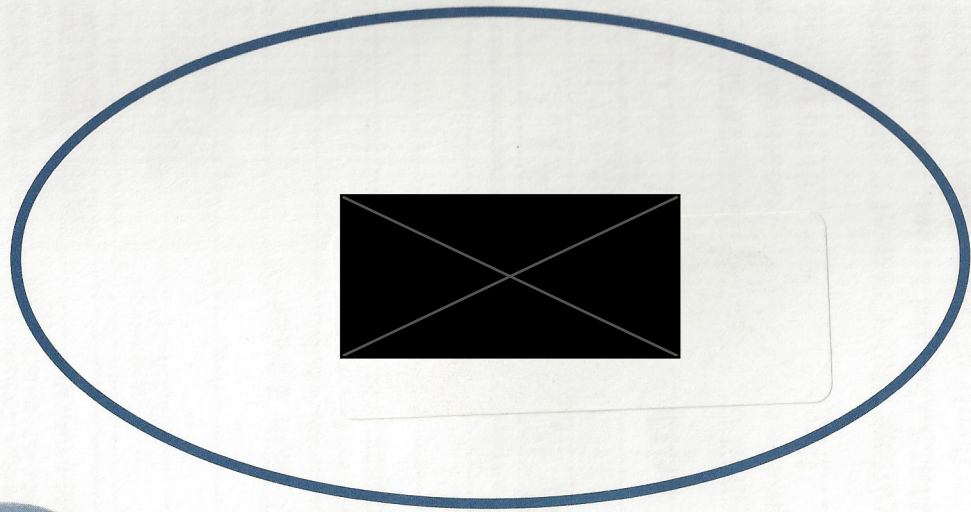

1946 Ford Coupe