

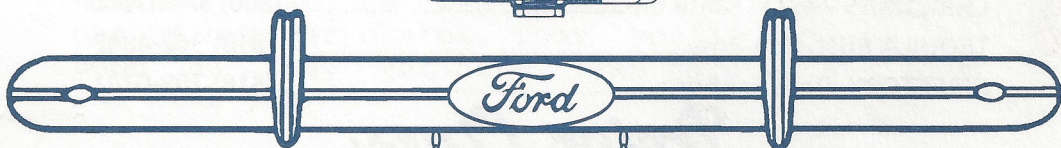

MARCH

Our 25th Year

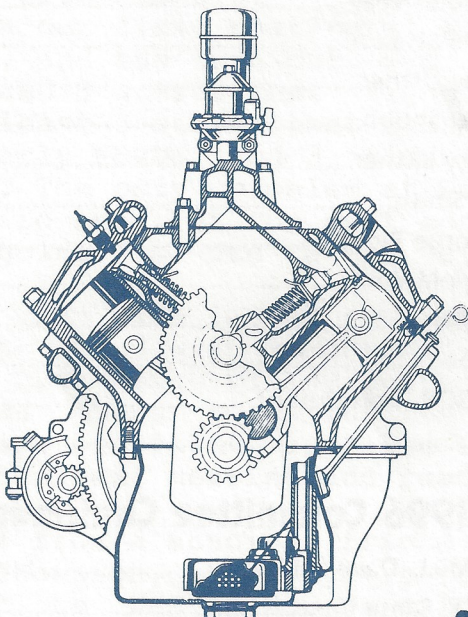

San Fernando
Valley *V-8's*
CHAPTER 40

Drive Lines

The Valley 's

1996 OFFICERS

PRESIDENT, Dick Smith.....	(818) 368-5890
VICE PRESIDENT, John Wolf.....	(818) 789-6201
SECRETARY, Joe DiFatta.....	(818) 700-1939
TREASURER, Lesley Littner.....	(818) 597-9016
PROGRAMS, Chuck Shubb.....	(818) 882-2927
ACCESSORIES, Jerry Littner.....	(818) 597-9016
HISTORIAN, Patti Smith.....	(818) 368-5890
MEMBERSHIP, George Richards.....	(818) 992-4537
FELLOWSHIP, Virginia Wolf.....	(818) 789-6201
RAFFLES, Chuck Mair.....	(818) 785-9413
EDITOR, Don Stout.....	(818) 998-7054
TECHNICAL ADVISOR, Don Durkee.....	(805) 495-5298
TOUR MASTER.....	EVERYONE

1996 Committee Chairmen

ANNUAL PEPPERMILL, Dave Sanborn.....	(818) 709-0741
CHRISTMAS PARTY, Santa Claus.....	(800) SANTA 40
TEQUILA RUN, Bob Rose.....	(818) 362-4842
DIRECTORY, Dave Sanborn.....	(818) 709-0741

Drive Lines

Published By

SAN FERNANDO VALLEY CHAPTER 40
of the EARLY FORD V8 CLUB OF AMERICA

P.O. Box 96
Reseda, CA 91335

PRESIDENT'S MESSAGE

March 1996

THE VALLEY V8'S 25TH ANNIVERSARY YEAR

Hello Fellow Club Members:

Well we had a our first meeting at Weiler's on a new night, and the turn-out was very good, 50 members and 3 guests that signed-in, and I know of at least 3 others that didn't sign-in. We had 17 early FORDS and 3 classic's of the other brand. The only problem at Weiler's was it was hard to hear, at the next months meeting we're going to use a PA system, that should help.

I received a very nice letter from Jay & Sylvia Harris on the honorary membership, its our pleasure to have such classy people as fellow members. I was going to print the letter in this DriveLine but Patti misplaced it, so I'll bring it to the next meeting and read it.

I had a call from a special friend and club member Tomy Thompson, it was great to here from him and what he was up to. He called wanting one of our car plates. Tomy you'll get one as soon as they get here. Take care we all love and miss you.

As for our February Trophy, lucky George Richards, won it again, he has got to be on a roll. He still won, even after I changed the rules there is no stopping him. Thank god he is going on a long vacation soon so there is still hope someone else may win. Just kidding George congratulations.

Yours Truly,

Dick Smith

**Meetings Now
On Tuesdays**

Tuesday, March 5, 1996 MEETING

The New Location & Night of the Week

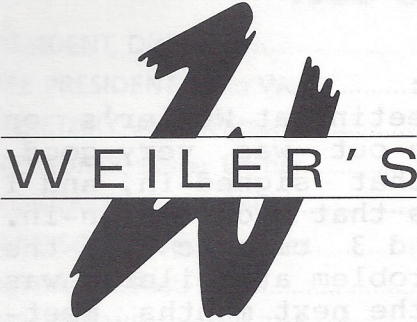
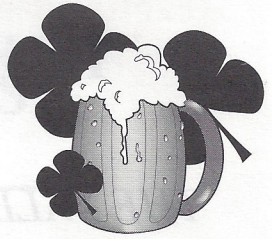

**Weiler's New York Style Deli
Restaurant • Bakery • Catering
16150 Nordhoff Street
North Hills, CA
(818) 892-8663 • Fax (818) 894-2443**

• 6:30 PM Parking Lot Tire Kicking & Visiting & Dinner if you want, the food is good!
7:30 PM MEETING STARTS

• Two ladies in attendance will receive a door prize.

The Trophy for the March 5th Meeting will be given to an early FORD 1932-53 product in the parking lot, to be chosen by a drawing, so bring your cars.

The name badge drawing (Jackpot \$40.00), to be given to a club member in attendance that is wearing their badge. CRAIG LAPAIR would of won, except he was not wearing his badge, sorry. Early Ford's driven to any meeting, tour, or events will receive points, at the November Meeting, the member who has the most points will WIN a \$100.00, and 2nd place will WIN \$50.00!

PROGRAM FOR THE EVENING

Our speaker for the evening is GEORGE RICHARDS on the restoration of his ... BEAUTIFUL ... 1939 FORD.

I'm looking forward to seeing you at the meeting on the 5th of March.

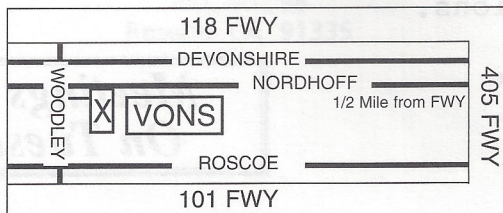

Reaction From Bill Clinton About Feb. 6th Meeting

by Walter Cronkite, Interviewer

- Walter Cronkite:* Mr. President Clinton, what did you think of our first dinner meeting at Weiler's Deli and the performance of President Dick Smith?
- President Bill Clinton:* First of all Walter, you can call me "Bill"... You know, I own a '65 Mustang and the secret service let's me drive it once in a while.
- Walter Cronkite:* "Bill", what about President Smith and our first Tuesday night meeting??
- President Clinton:* Hillary and I were sitting next to some Italian, and I did notice a "Record Crowd". Lots of ladies and even lots of Early Fords. Lesley Littner announced that there are currently 60 paid members and it's great to see Cliff Vess joining.
- Walter Cronkite:* Bill, let me rephrase the question about President Smith ... Is he on par to being a great leader?
- President Clinton:* Even though Weiler's Deli was noisy, the club will go there next month, Tuesday March 5th. Someone will bring a microphone and speaker. Your member, Don Durkee, has a great weekend planned in Solvang on the weekend of April the 13th. Hillary and I plan to attend - call him at (805) 495-5298.
- Walter Cronkite:* Was President Smith the secret handshaker?
- President Clinton:* Don't mention "Secret". I avoid the "secret guys" all of the time. I did notice, Chuck Mair with the assistance of Don's Auto Parts and Tom Sawyer Shell, lots of raffle prizes were given away. And always thanks to Patti Smith for her contributions of prizes. It's always nice to have a "First Lady" close by.
- Walter Cronkite:* Did you notice that President Smith presented George Richards with the "Car of the Month" award?
- President Clinton:* I heard George won the trophy last month. I heard he is building a trophy case in his living room.
- Walter Cronkite:* What about the program?
- President Clinton:* It was great with Ray Lupoli, speaking about total restorations of his '35 Ford. He complimented members in the Ford groups for their assistance. Originally, the '35 had a pickup box in the trunk ... so Ray replaced the whole rear clip. Purchased and installed a '59AB engine from a "wind machine" electrical farm. Great idea. Even had some great photos. A great restoration.
- Walter Cronkite:* Will you and Hillary will be attending our March 5th meeting?
- President Clinton:* I checked my calendar, but do I have to sit next to the Italian, that owns Chevys, Plymouths and one Ford?? Hopefully, I'll have a chance to win the \$40.00 jackpot!! To answer your "repeated" question about President Dick Smith ... He sure is nice to the ladies when they attend the Ford meetings.

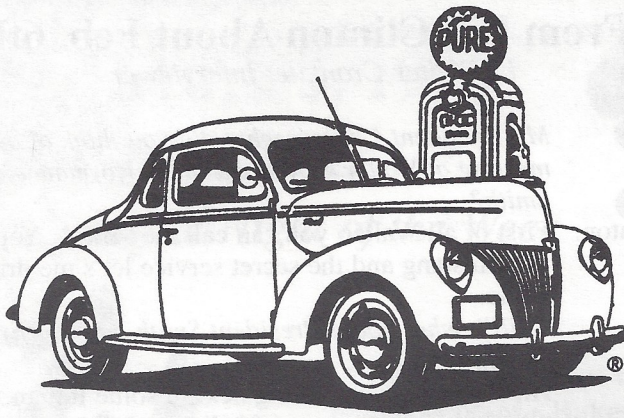

EARLY V8 FORDS DRIVEN TO THE MEETING

- 1939 Ford Convertible – George Richards
- 1940 Ford Pick Up – David & Rose Gott
- 1953 Ford Coupe – Lloyd & Donna Paschal
- 1941 Ford Convertible – Judy & Chuck Shubb
- 1950 Ford 4 Door – Ed & Jan Hardin
- 1932 Ford Roadster – Richard Stone
- 1940 Ford 4 Door – Al Rohrer
- 1939 Ford Convertible Sedan – Jerry Jensen
- 1940 Ford Coupe – Gerry & Blacky Blackwell
- 1950 Ford Coupe – Don Durkee
- 1948 Ford Coupe – Joe DiFatta
- 1940 Ford Coupe – Lin & John Kemmerer
- 1940 Ford Tudor – John & Virginia Wolf
- 1940 Ford 2 Door – Ken Sapper
- 1927 Ford T-Roadster – Bob Monnick

All of the above cars have one point towards the November JACKPOT.

CARS & PARTS FOR SALE

'46 Front End Complete, with Brakes;

'46 Stainless 2 Door Sedan, & Steering Column
Allan Franklin (818) 842-2230

Nos 4.44 Rear End Gears \$275.00
Dennis (213) 665-1363

'41 Ford Bus Coupe \$8500
Great Shape
Earl Hames (818) 893-2463

'47 Pick-up Rob (818) 272-0410

'31 Model A, 5 Window Coupe - All
Restored to original condition, 16"
Wire Wheels and Hydraulic Brakes
Steve Modugno (818) 365-3204

WANTED: 4 - 15" wheels for a 1940 Ford & 24 Stud Motor & Trans — Al Rohrer (818) 345-3721
1940 Hoot Latch Mech. Craig (818) 893-1640

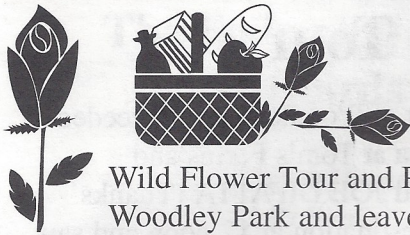

MARCH TOUR

Wild Flower Tour and Picnic on Sunday March 31st. we will meet at Woodley Park and leave at 10 a.m. Bring family and friends and your Picnic Baskets and Blanket, and head out with the group for one of our better tours.

Let Dick Smith know if you would like to join us.

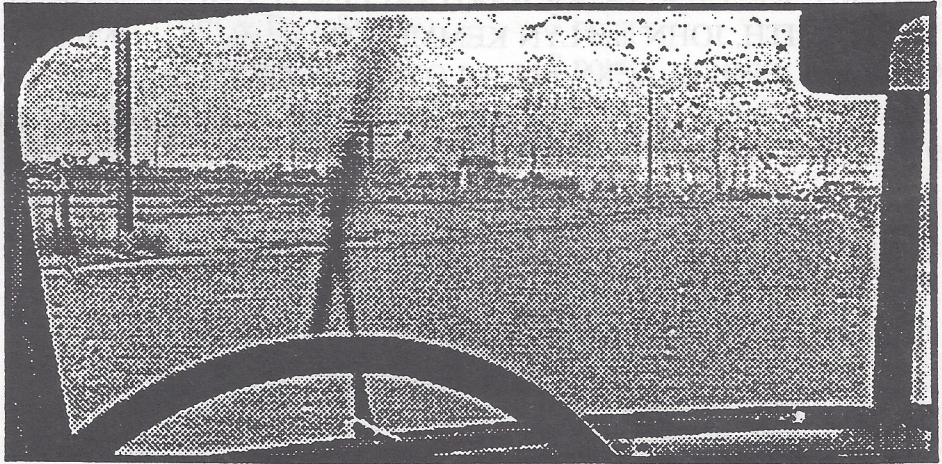

“LOOKING AHEAD”

MARCH—

TUESDAY, MARCH 5th. Meeting at Weiler's Restaurant.

MARCH 17th. Saint Patrick's Day

SUNDAY, MARCH 31st. Meet at Woodley Park, for Wild Flowers tour and picnic (See article)

APRIL

TUESDAY, APRIL 2nd. Meeting at Weiler's Restaurant

TUESDAY, APRIL 23rd. (New Date) “Lets Play Hookey”. Meet at Lamplighter's Restaurant on Van Nuys Blvd. (just north of the 101 Freeway) for Breakfast & Garage Tour in Pasadena. Call Dick Smith.

Grand C & G Tour

Twenty two Ford Members and guests met at Woodley and proceeded to C&G Ford Parts showroom. We stopped in Corona at Tom's Farms and celebrated the birthdays of LYN KEMMERER and JOE DIFATTA (Thanks JOHN for bringing the cake). We arrived at our destination at 12 noon and saw lots more Fords and Members from the San Diego Chapter. Good Food, a great visit and lots of winners from the raffle. The following attended:

DON STOUT, JOE DIFATTA, RICHARD VALLEROY, CHUCK MAIR, DICK and PATTI SMITH, JOHN and LYN KEMMERER, AL and LUANNE ROHER, BLACKY and JERRI BLACKWELL, LLOYD and DONNA PASCHEL, DICK and DIANE STONES, CRAIG LUIPER, TERRY SMITH, DAVID GOTT and his son JAMES, and JOHN and VIRGINIA WOLF.



The Following Cars and drivers Have Points Towards The November Jackpot

John & Virginia Wolf	2 points
Al Rohrer	2 points
George Richards	2 points
Lloyd & Donna Paschal	2 points
Don Durkee	2 points
Joe DiFatta	2 points
Patti & Dick Smith	2 points
David & Rose Gott	2 points
Lin & John Kemmerer	2 points
Dick Stone	2 points
Jerry & Lesley Littner	1 point
Cal & Nancy Beauregard	1 point
Wayne Burns	1 point
Richard Chutuk	1 point
Jerry Jensen	1 point
Judy & Chuck Shubb	1 point
Ed & Jan Hardin	1 point
Ken Sapper	1 point

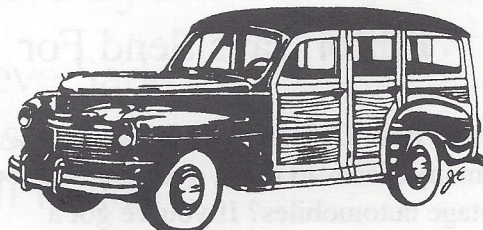

POMONA MARCH 10

Editor's Column

March is just around the corner with the Wild Flower Tour and Picnic; invite some friends to tag along

Your Editor has had some difficulty explaining what we print and how the number of pages must be divisible by four (4 - 8 - 12 - 16). February issue was 12 pages plus the cover; but if you send it in, it will be printed...

Notice our new advertisers this issue; we thank them, and all of our continuing supporters.

We also have four new members this month (see George Richard's list). The '40 restoration seems to have slowed down, but continuing. Gas tank back good as new; radiator re-cored; all gauges re-faced. Speedometer and odometer rebuilt and set to zero. Radio purchased and completely rebuilt, and a set of **Zephyr 26** tooth gears found for transmission. Window frames at Bob Kennedy for wood graining and floor pans for trunk area ready to install. Someday!

Remember, we vote at our March meeting on Meeting Place.

Editor Says Send For

Love Those Oldies: Who knew there were so many places to drool over (but not touch) vintage automobiles? If you've got a yearning for chrome wheels, mahogany dashboards and mohair upholstery, check out the free guide to automotive museums and displays from Eagle One car-care products, which is celebrating its 100th anniversary. To order, send a stamped, self-addressed business-size envelope to Eagle One, Suite 409, 15720 Ventura Boulevard, Encino, California 91436.

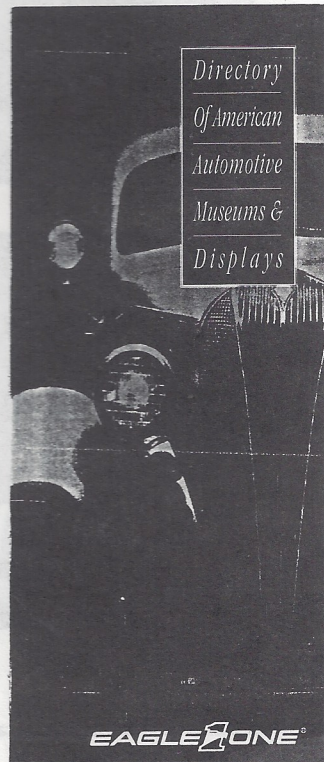

Welcome New Members!!

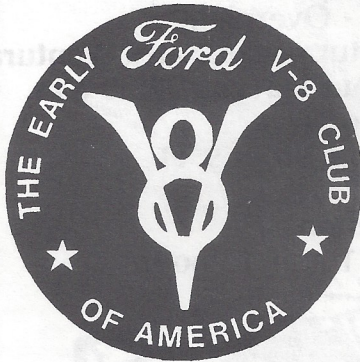

Lee and Suzanne Chase
'38 Deluxe Four Door

Bob and Karen Reed
'51 Lincoln

Cliff and Judy Vess

Don and Barbara Zabel
'48 F1 Flatbed
'46 Sprint Car



March V8 Birthdays

- March 3 Steve Sadd
- March 12 Susan Faber
- March 15 Bill Nolan
- March 16 Tom Riela
- March 18 Ed Wornock
- March 18 Ruth Mottern
- March 21 Dennis Keene
- March 25 Kent Lowry
- March 26 Sharon Foster
- March 30 Ruth Thompson

SOLVANG - V8 TOUR

Hosted By: Don & Mary Durkee (805) 495-5298
When: Saturday, April 13th, 1996 - Overnight
Meet: Carrows Restaurant at Ventura & Seaward, Ventura
Time: 8:00 a.m. for breakfast - Tour leaves at 9:00 a.m.
Bring: Sack Lunch for Saturday Noon
What: Poker Run, Trivia Quiz, Car Games 9 11
Meet: Santa Barbara at 10 a.m.
Central Coast V8ers in Buelton
Jack Mendenhall Museum 11 a.m. to noon

Solvang Shopping: 12 to 5 p.m.

Motel: Royal Scandinavian Inn
400 Alisal Road
Phone: (805) 688-8000 or (805) 624-5572

Cost: \$90.00

Evening: PORK PALACE \$26.00 per person
Milking Barn - Restoration Hour 5 p.m. to 6 p.m.
Milking Barn - Dinner: Tri-Tip Barbeque 6 p.m.
Parlor Barn - Program 7 p.m.
Magic Show 8 p.m.

Sunday: Nojoque Park 11 a.m.
Free Hot Dogs
Hosted by Ventura V8s
Bring your own drink

RESERVATIONS MUST BE MADE BY MARCH 13, 1996

Wise Words For The Month

Whether you think you can or you
think you can't, you are right.

Henry Ford

FARMERS MARKET / STREET FAIR
SWIMMING POOL / HOT TUB
VAUDEVILLE
SLO ROADSTERS CAR SHOW
AND
BACK COUNTRY TOURING IN AN EARLY V-8

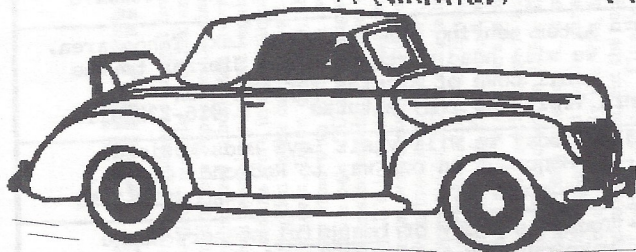

Gas up your V-8 for a Fun Tour to SAN LUIS OBISPO
on Thursday, Friday, & Saturday - MAY 9, 10, & 11, 1996

THURSDAY

Morning: Depart from Ventura @ 9:30 A.M.

Day: Tour to San Luis Obispo

Night: Farmers Market / Street Fair (Barbeque, street mimes, corn on the cob, folk dancers, street musicians, ice cream cones, handcrafts, balloons & more!)

FRIDAY

Morning: Free Continental breakfast @ Motel

Day: Mystery Tour - you gotta be there to find out where.

Night: The Great American Melodrama in Oceano "Vaudeville" (\$14.00 each)

SATURDAY

Morning: Free Continental breakfast @ Motel

Day: San Luis Obispo Car Show (one of the largest on the Central Coast)

SUNDAY

Morning: Free Continental breakfast @ Motel

Day: Tour down 101 to home. (Stop in Solvang for lunch.)

Make your MOTEL RESERVATIONS NOW!

The Lamplighter Inn - TOLL FREE (800) 547-7787. The car show draws over 300 cars mostly from out of town, so reserve now! Rates: Queen \$64; King \$69 plus tax

If you can join us PLEASE RSVP IMMEDIATELY. Call Dennis Keene at (213) 665-1363.

MELODRAMA RESERVATIONS NEED TO BE MADE WITH DENNIS.

DEADLINE is MONDAY, April 8, 1996.

HARRIS TOUR TO CANADA

Yes, it's time to start thinking about attending the Western National Meet in Victoria, British Columbia this year. The 'Harris' tour is all planned - a 7½ day tour of fun and sightseeing. Here is our itinerary, hotel stops, and just some of the sightseeing that is planned

DAY 1 - Sunday, July 28 - Tour departs from the Super 8 motel, Palmdale.
We will follow US 395 north to Bishop.

HOTEL: Best Western Creekside Inn, Bishop 619-872-3044

DAY 2 - Monday, July 29 - We will travel north to Lake Tahoe for the night. Several scenic stops along the way.

HOTEL: Super 8 Motel, South Lake Tahoe 916-544-3476

DAY 3 - Tuesday, July 30 - After touring the beautiful Lake Tahoe area, we will head north thru the Sierras to the small town of Alturas for the night.

HOTEL: Best Western Trailside Inn, Alturas 916-233-4111

DAY 4 - Wednesday, July 31 - Today we will visit Lava Beds National Monument on our way to Redmond, Oregon.

HOTEL: Redmond Inn, Redmond, Or. 1-800-833-3259

DAY 5 - Thursday, Aug 1 - Today is a day of beautiful scenery as we make our way to Mt Hood, and the historic Timberline Lodge, then a stop in a gorgeous park for lunch, then on to Stevenson, Wa.

HOTEL: Skamania Lodge, Stevenson, Wa. 1-800-221-7117

DAY 6 - Friday, Aug 2 - Today the tour winds thru the Columbia River Gorge area and it's many waterfalls and lush scenery, followed by an up-close-and-personal visit to the Mt St Helens volcanic eruption area. This is a must-see attraction.

HOTEL: Nendels Motor Inn, Chehalis, Wa. 360-748-0101

DAY 7 - Saturday, Aug 3 - Today's stops include the famous Space Needle in Seattle, and The Sportsman Shop - a restoration facility catering to Sportsmans. A personal tour by the owner is planned.

HOTEL: Best Western College Wy Inn, Mt Vernon 360-424-4287

DAY 8 - Sunday, Aug 4 - Our final day will include a ferry boat ride through the beautiful San Juan Islands as we make our way over to Vancouver Island, B.C. and on to Victoria, site of the 1996 Western National Meet at the Empress Hotel.

That's it!! If you plan to join us I urge you to make your hotel reservations now. Many hotels book up early during the vacation season, and I already have 12 couples who have called me and are planning to go! You can always cancel later if you can't make it. You must RSVP to me by June 1st if you're coming along. ..e hope you do.

Jay Harris
619-728-0311

1946 Ford Super Deluxe used as California police car

By Rick Feibusch

When peace broke out at the end of World War II, it was time for the automakers to re-tool from military production to personal transportation. Ford, like most other car builders, dusted off its 1942 tooling and went to work on simple trim and grille facelifts. It started spitting out as

many "1946" models as possible. With no new cars for over four years, the public snapped up any available cars.

Government agencies were also limping along on well-worn vehicles and, at times, got priority over the public. This '46 Ford Super Deluxe Tudor sedan was purchased by the Oakland (Calif.) Police Department.

Most city governments bought low-priced, "fleet" models, but Oakland was forced into a Super Deluxe since Ford saw no need to build the prewar, entry-level Special model, and regular Deluxe sedans were in short supply. The only option on the car was a set of 15-in. wheels. Upon delivery, the sedan was fitted with an Edison two-way radio, a pair of Unity spotlights, some white side panels, and a star on the door. It's interesting that, in a short time, we've come from stock Fords with broadcloth upholstery, to today's screened-in, rolling mini-jails.

This car is owned by Skip Silva, of San Leandro, Calif. For years, it was languishing away in the garage of a neighbor who had bought it at a Oakland city auction in 1950. The Tudor had 63,000 miles on it. It was driven home, parked in the garage and just let to sit. By the '70s, the car's engine had frozen, but the neighbor still refused to sell. Finally, in 1978, in the midst of a divorce, he had to sell the car and called Silva.

Silva pulled the cylinder heads, and hammered on each piston until it came loose. He then buttoned the engine up and drove it off. After a while, it started smoking pretty bad. The heads and pan were removed, and new rings and rod bearings were installed. It now has over 68,000 miles on its odometer, and runs great.

Silva has done a few modifications. He works for the City of San Leandro, and had access to a set of modern radial, 15-in., police pursuit tires

taken off a wrecked patrol car. They fit nicely on the Ford's optional wheels. Two-inch longer front shackles lower the front end a bit. The "baby moon" hubcaps are temporary, until a nice set of originals can be obtained.

On patrol in a '46 Ford "squad"

Slide behind the wheel with me and we'll take a ride. The car feels big, but not *too* big or overstuffed. It's tall, with lots of headroom. All of the controls are easy to get to, and the steering wheel is at a tolerable angle. The car starts smoothly and settles down to that lovely flathead burble.

The gear shifter works well, as it slides into first. Give it a little pump, and we're off. Smooth and powerful are the words that come to mind as we run it through the gears. I never drove an original, stock-powered, postwar Ford sedan before. I was really surprised at its performance. I'll bet that only a few luxury cars, with big engines and tall gearing, could run away from it. It leaves stock Chevs and Plymouths in the dust.

The handling is also very good. In my experience, radial tires usually make older cars feel mushy and squirmy. Here, the tires canceled the straight-axle Ford's tendency to follow imperfections in the road and "hunt" from side to side. It rode smoothly and required much less correction at the helm. A run, over to an industrial area, allowed me to test the siren. It wound up slowly, just like in the movies, and took at least three minutes to wind down. Great stuff!

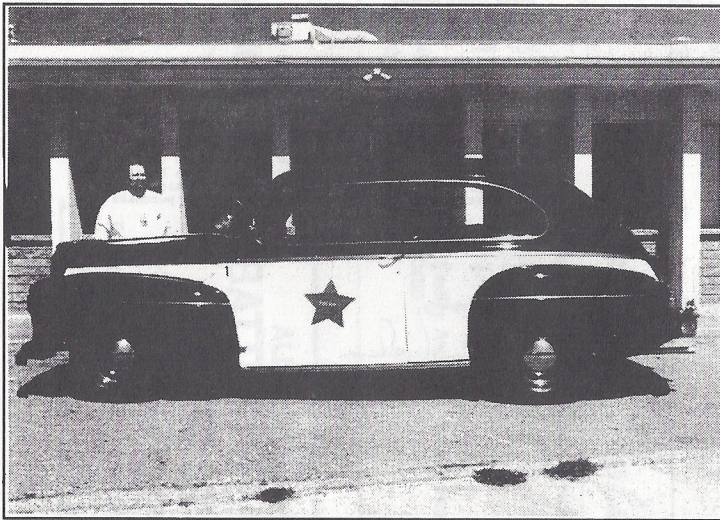

Skip Silva is still working on this baby. The Oakland library has used it in promotions and the police department is trying to locate the correct period star for the door. It is always a big hit at car events.



13460 Van Nuys Boulevard • Pacoima, CA 91331 • (818) 896-0246 • (818) 897-2443 • FAX (818) 897-5642

NON-PROFIT ORGANIZATION

January 3, 1996

Valley V-8 Antique Car Club
Attn: Mr. Al Spencer
3948 Goodland Ave.
Studio City, CA 91604

Dear Mr. Spencer:

It's with a warm and happy heart that I write you this season to thank you for your generous contribution to our Christmas Program. Your donation of thirty new toys was very much appreciated.

We were able to bring food, toys, clothing, blankets and other necessities of life to more than one thousand low-income families. Without your faithful commitment to MEND and its work, it would not have been possible. The parents' burdens were lighter, and the children's Christmas had more joy because of you. May God bless you and your family for remembering those who need assistance at this very special time of the year.

Our new building is well on its way to completion. We were able to use part of it this year for getting the presents wrapped, and the Christmas Baskets filled and distributed. We are grateful to our benefactors who so consistently and graciously support us. You are truly our partners in this ministry!

The MEND Community gives thanks to God and remembers you in its prayer.

Sincerely,

Alice Beck
Volunteer



CATHOLIC CHARITIES

LOAVES & FISHES II
14525 DELANO STREET, #102 • VAN NUYS, CA 91411
(818) 997-0943 • FAX (818) 997-6980

January 8, 1996

Valley V8 Ford Club
DiFatta Graphics
27642 Avenue Hopkins
Valencia, California 91355

Dear Joe:

I would like to take this opportunity to thank you so very much for your generous contribution to Loaves & Fishes this past Holiday Season. Because of your generosity many needy people went home with extra bags of groceries and children were given new toys which they ordinarily would not have received. Our homeless clients were given a nice warm blanket and script from local markets to purchase food.

We certainly appreciate your kindness and support throughout the year. I hope you have a very Healthy and Happy New Year!

Warmest Regards,

Barbara Ausburn
Volunteer Director

SUPPORT OUR ADVERTISERS!

FLIP SMITH

Chatsworth Auto Upholstery

Classics • Hot Rods • Foreign & Domestic

JIM ORTUNO
(818) 882-5161

21300 DEVONSHIRE ST.
CHATSWORTH, CA 91311



7735 SEPULVEDA BOULEVARD
VAN NUYS, CALIFORNIA 91405

Bus: (818) 786-8686

Fax: (818) 785-2982

DON'S Auto Parts

MACHINE SHOP and BALANCING

Monday thru Friday 8 a.m. to 7 p.m.
Saturday 9 to 6 - Sunday 10 to 4

10241 Woodley (At Devonshire)

Domestic &
Foreign

Parts & Supplies



(818)
894-6441

Sepulveda, CA 91343

RAFFLE PRIZE DONOR

LESLEY A. LITTNER
(818) 597-9016 / FAX:597-9145

BOOKKEEPING & BUSINESS SERVICES

5051 BLACKPOOL AVE.
AGOURA, CA. 91301



Older Cars
A Specialty

4 x 4's and
Motorhomes

Russell Sylvis, Inc.
Transmissions
Repaired • Rebuilt

(805) 527-4387

4657 Barnard St.
Simi Valley, CA

R.C. Smith's Roofing Solutions

Roofing & Waterproofing • Complete Maintenance Service

8707-D Lindley Ave., Ste. 199, Northridge, CA 91325
Lic. #356650 (818) 718-2313

Auto • Homeowners

- ANTIQUE CARS -

ED HARDIN INSURANCE

Business • Life • Health • Aircraft



Call us for your Insurance needs!

(818) 363-7864

ALLAN FRANKLIN'S BATTERY TENDER \$59.99

club members
\$54.99

Charges battery up and turns itself off
automatically when it fully charged.

Takes the guess work out of battery maintenance!

(818) 842-2230

6, 8, or 12 Volt Models

SUPPORT OUR ADVERTISERS!

L.T. "LEE" SAWYER, INC.

Jobber

Shell Oil and Chemical Products

14117 Aetna Street, Box 369
Van Nuys, California 91408

TOM SAWYER (818) 786-8180 / (818) 785-0902

RAFFLE PRIZE DONOR

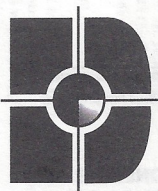

**DiFATTA
GRAPHICS**
Incorporated

Joe DiFatta
Chief Executive Officer

27642 Avenue Hopkins
Valencia, California 91355

Phone: 805 295-8788
800 990-1939
Fax: 805 295-5069
Modem: 805 295-5119

CHEVY AND FORD TRUCKS • 4 x 4
55-56-57 67-87 64-87
CHEVY CARS CAMARO CHEVELLE
NEW AND USED PARTS

**American Auto & Truck
Dismantlers**

12172 Truman St. • San Fernando, CA 91340
(at Hubbard) **ROGER** (818) 365-3908

RESIDENTIAL • COMMERCIAL • INVESTMENT



Spencer Realty

5948 Goodland Ave.
Studio City, CA 91604
Office: 818-761-1754
Fax: 818-761-7952



AL SPENCER
QUALITY PROFESSIONAL SERVICE



John Mangiapane
(818) 994-5077

14743 Keswick Street
Van Nuys, CA 91405

Low prices
Repiping Specialist

Commercial & Residential
All Drain & Plumbing Needs

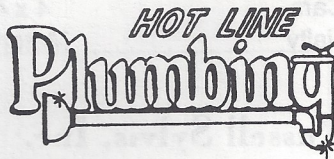

(818) 315-8601
State Contractors Lic. #682431

JED

TEENAGE PRAYER

God is like Bayer Aspirin...He works wonders
God is like Pepsi...He's got a lot to give
God is like Ford...He's got a better idea
God is like Dial Soap..He gives around-the-clock
protection.

God is like Coke...He's the real thing
God is like Pan America...He makes the going great
God is like Scope...He keeps you fresh all day
God is like Hallmark...He cared enough to send the
very best!

AMEN

PAST PRESIDENTS

JIM ROWE.....	1971
DOUG PETERSON	1972
DON DURKEE	1974
ED WARNOCK	1975
JOHN BUSK.....	1976
CHIP WERSTEIN	1977
STAN MARSRAJE	1978
BOB DRAKE	1979
BILL CULP.....	1979
AL SPENCER.....	1980
LARRY CAPLAN	1981
BOB ROSE	1982
DON DURKEE	1983
PAUL KIRK	1984
KENT LOWRY	1985
DAVE SANBORN.....	1986
JOHN KEMMERER.....	1987
DUDLEY OCHSNER.....	1988
JERRY JENSEN	1989
JERRY JENSEN	1990
JOE DIFATTA.....	1991
CHUCK SHUBB.....	1992
CHUCK SHUBB.....	1993
GEORGE RICHARDS.....	1994
JERRY LITTNER	1995

Meetings are held on the first Sunday of every month at 7:00 p.m.

The Valley 's

10532 GERALD AVE., GRANADA HILLS, CA 91325

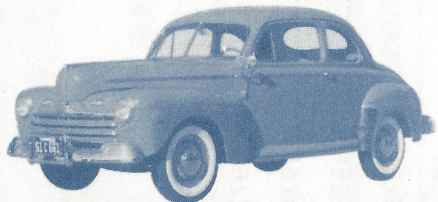
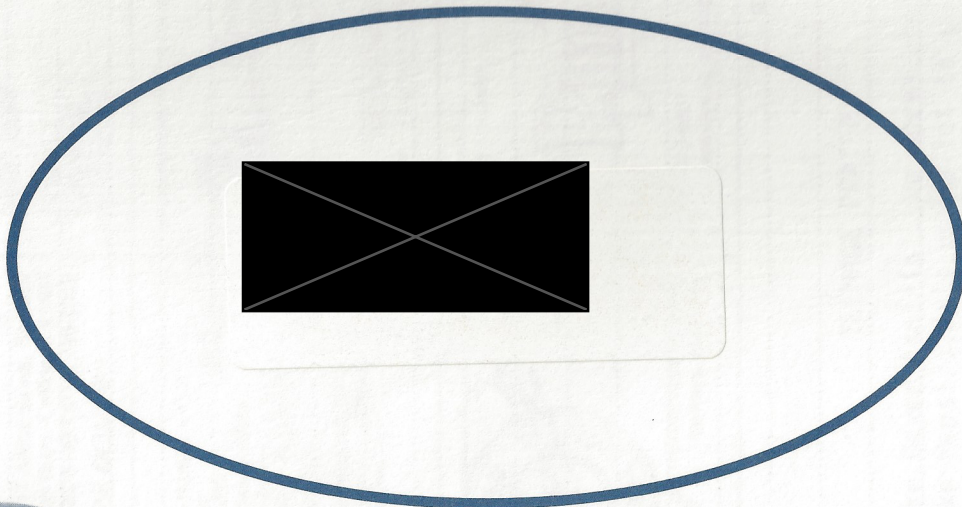

1946 Ford Coupe