

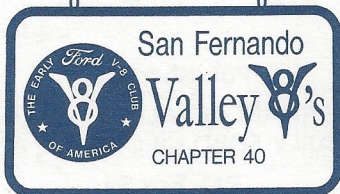

AUGUST

Our 25th Year

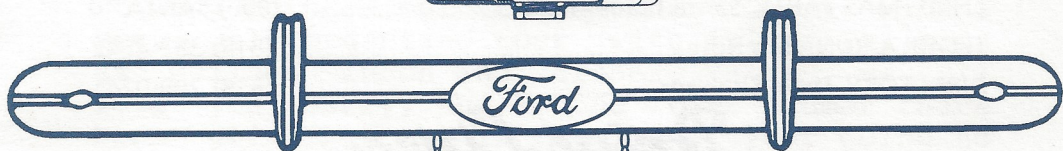
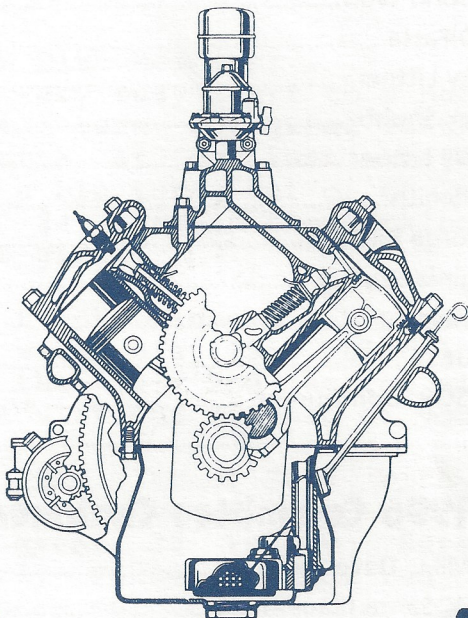

Drive Lines

The Valley 's

1996 OFFICERS

PRESIDENT, Dick Smith.....	(818) 368-5890
VICE PRESIDENT, John Wolf.....	(818) 789-6201
SECRETARY, Joe DiFatta.....	(818) 700-1939
TREASURER, Lesley Littner.....	(818) 597-9016
PROGRAMS, Chuck Shubb.....	(818) 882-2927
ACCESSORIES, Jerry Littner.....	(818) 597-9016
HISTORIAN, Patti Smith.....	(818) 368-5890
MEMBERSHIP, George Richards.....	(818) 992-4537
FELLOWSHIP, Virginia Wolf.....	(818) 789-6201
RAFFLES, Chuck Mair.....	(818) 785-9413
EDITOR, Don Stout.....	(818) 998-7054
TECHNICAL ADVISOR, Don Durkee.....	(805) 495-5298
TOUR MASTER.....	EVERYONE

1996 Committee Chairmen

ANNUAL PEPPERMILL, Dave Sanborn.....	(818) 709-0741
CHRISTMAS PARTY, Santa Claus.....	(800) SANTA 40
TEQUILA RUN, Bob Rose.....	(818) 362-4842
DIRECTORY, Dave Sanborn.....	(818) 709-0741

Drive Lines

Published By
SAN FERNANDO VALLEY CHAPTER 40
of the EARLY FORD V8 CLUB OF AMERICA

P.O. Box 96
Reseda, CA 91335

PRESIDENT'S MESSAGE

August 1996

THE VALLEY V8'S 25TH ANNIVERSARY YEAR

Hello Fellow Club Members:

It's been a very busy start to a hot summer. Our Sunday Social turn out great THANKS to Marsha & Joe Di Fatta. At our last meeting on July 2nd we had a big turn out of 61 members and guests, and 24 cars in the parking lot, nice going guys & girls.

We had two trophy winners Bob Reed at the Sunday Social with his 1951 Lincoln and Jerry Jensen at the July 2nd meeting with his 1939 Tudor congratulations to both of you.

The Tour on the 13th of July with Ventura V8s was great, of course all of Gerry Blackwells tours are great, 30 Valley V8ers showed up with 13 early FORDS plus the Ventura members. It was pointed out to me that Gerry runs a very well organized tour with itinerary, maps as well as lunch and dinner. THANKS, we all love you Gerry, and I hope that rumor that's been going around is true, that your going to be the President for 1997, this Club sure needs a Gerry Blackwell.

The Outstanding members of the month for all their hard work and effort our Marsha & Joe Di Fatta and Gerry Blackwell, THANKS for everything.

Yours Truly,

Dick Smith

This Month Only CHANGE OF DATE

Tuesday August 20th Meeting

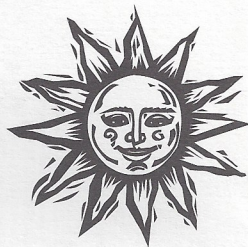

Weiler's New York Style Deli
Restaurant • Bakery • Catering
16150 Nordhoff Street
North Hills, CA
(818) 892-8663 • Fax (818) 894-2443

6:30 PM PARKING LOT TIRE KICKING & VISITING
& Dinner if wanted, the food is good.
7:30 PM MEETING STARTS

Two ladies in attendance will receive a door prize.

The Trophy for the AUGUST 20th Meeting will be given to a early FORD 1932-53 product in the parking lot, to be chosen by George Richards, Jerry Jensen, and Chuck Shubb they are the judges, so bring your cars.

The name badge drawing (JACKPOT \$20.00), to be given to a club member in attendance that is wearing their badge.

Early FORD's driven to any Meeting, Tour, or Events will receive points, at the NOVEMBER MEETING, the member who has the most points will WIN a \$100.00, and 2nd place will WIN \$50.00.

GREAT PROGRAM FOR THE EVENING, we need you!!!!

Crab Mold

by Gerry Blackwell

1 can tomato soup
2 3oz pkgs cream cheese
Mix in blender and heat in saucepan
Mix 1 1/2 pkgs. gelatin in 1/2 cup water
Pour into heated mix and let cool

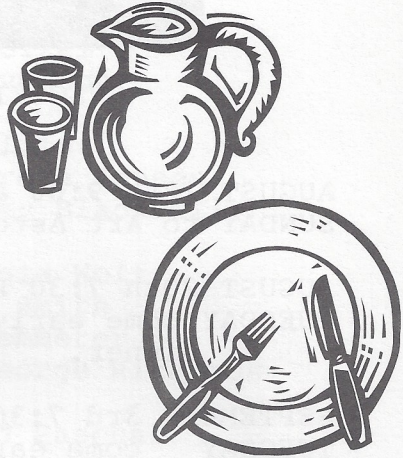

Mix
1 cup mayonnaise
1 cup chopped celery
1 cup chopped onion
1 small can shrimp – drained
1 small can crab – drained

Pour into fish mold and refrigerate.

Editor Says.....

Another busy month and a long time between meetings. The Social at Marsha & Joe's was a real success; fun with Fords.

The tour I missed, so I won't comment!

On the 18th, before our next meeting, the Astor Tour is scheduled. The meeting on the 20th is to accommodate the Victoria Tour Contingency leaving Sunday.

Not much to report on my restoration: Running boards are back from Georgia; Hunley did a great job! I picked up my "tiger tailed" window frames from Bob Kennedy -- they are beautiful -- what a talent!

Keep those card and letters coming -- Yeah right!!!

Ed

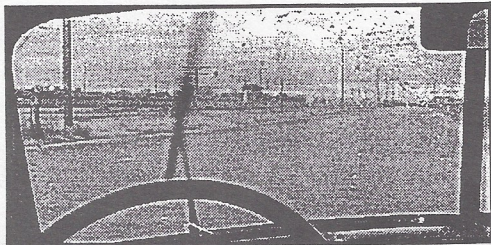

"LOOKING AHEAD"

AUGUST 18th 9:00 AM Woodley Park the TOUR
SUNDAY to Art Astor car collection.

AUGUST 20th 7:30 PM Meeting at Weiler's
TUESDAY come early for tire kicking and
dinner.

SEPTEMBER 3rd 7:30 PM Meeting at Weiler's
TUESDAY come early for tire kicking and
dinner.

SEPTEMBER 22nd Eleventh Annual PEPPERMILL
SUNDAY BRUNCH, Doors open at 10:00 AM

OCTOBER 1st 7:30 PM Meeting at Weiler's
TUESDAY come early for tire kicking
and dinner.

OCTOBER 20th 9:00 AM Meet at Woodley Park
SUNDAY TOUR to San Sylmar.

NOVEMBER 5th 7:30 PM Meeting at Weiler's
TUESDAY come early for tire kicking and
Dinner.

DECEMBER 1st THE CHRISTMAS PARTY at the
SUNDAY SMOKEHOUSE 6:30 PM.

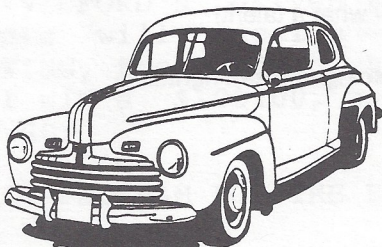

Ford Fact

In 1932, a significant source of income for Ford came from the parts business, which totaled \$46 million or 18% of total dollar sales. There were approximately 7 million Fords in service, of which nearly 60% were still Model T's. Spare part demand for Model T was plummeting, yet Ford sold 135 brand-new Model T engines.

*Presented by the
Early Ford V8 Foundation*

EARLY V8 FORDS DRIVEN TO THE MEETING

1941 FORD Conv. Chuck Shubb
1937 FORD Cpe. Jerry & Lesley Littner
1940 FORD 4 door Al Rohrer
1950 MERC. Ken & Dotti Schmelzel
1940 FORD Pick-up Rose & Dave Gott
1932 FORD Rdst. Dick Stone
1951 FORD 2 door Les Mac Willie
1939 FORD 2 door Jerry & Carole Jensen
1940 FORD Cpe. Gerry & Blacky Blackwell
1948 Ford Cpe. Joe Di Fatta
1940 FORD Cpe. John & Virginia Wolf
1940 FORD Cpe. Patti & Dick Smith
1940 FORD Cpe. Lin & John Kemmerer
1939 FORD Conv. Shirley & George Richards
1951 LINC. Bob Reed
1953 FORD Cpe. Donna & LLOYD Paschal
1941 FORD Cpe. Chuck Mair
1932 FORD Rdstr. Harold Johasen
1939 Merc. Leon Nitz
1942 FORD Wayne Burns

The other classic cars driven were,
Cliff Vess 23 T bucket, Don Stout 56 Chevy,
Bob Zecher Mod, & Al Axelrod 72 Pantera

CARS AND PARTS FOR SALE

81A short block fresh, 59A short block fresh,
8BA short block fresh, they all have 4" cranks
\$1,800.00 ea. Call Jack Miles 818 347-8617
New 670X15 Black tire Chuck Mair 818 785-9413
Crankshafts 36 to 48 10-10 Harold Johansen
818 789-1068
85 Corvette 104K loaded \$7,995.00 4-15" wheels
& Firestone tire W/W worn \$125.00 68 chev trans
HD 3 speed \$150.00 Lloyd Paschal 805 527-6464
46 Ford front and rear end Allan Franklin
818 842-2230

CARS & PARTS WANTED

'33, '34, '35, '36 5 window running Call Al
310 475-3642
Early 1910-30 Neihoff ignition parts book to copy
Allan Franklin 818 842-2230

The following cars and drivers have points towards the November JACKPOT

Lin & John Kemmerer	11 points
John & Virginia Wolf	13 points
Al Rohrer	9 points
Patti & Dick Smith	12 points
Dick Stone	9 points
Gerry & Blacky Blackwel	10 points
David & Rose Gott	11 points
Geroge Richards	6 points
Lloyd & Donna Paschal	8 points
Jerry & Lesley Littner	8 points
Jerry & Carole Jensen	8 points
Don & Mary Durkee	5 points
Ken Sapper	2 points
Judy & Chuck Schubb	6 points
Richard Valleroy	7 points
Wayne Burns	3 points
Ed Hardin	1 point
Bill King	1 point
Richard Chutuk	1 point
Bob Rose	1 point
Cal & Nancy Beauregard	1 point
Vicki & Dennis Keene	3 points
Chuck Mair	6 points
Steve & Sue Boskovich	3 points
Carlos Wilhelm	2 points
Allen Franklin	1 point
Dave Sandborn	2 point
Bob & Jackie Monnick	3 points
Leslie Mac Willie	3 points
Don & Cheryl Stout	1 point
Ken & Dottie Schmelzel	5 points
Larry & Ann Caplan	1 point
Howard & Barbara Simpson	1 point
Bob Reed	2 points
Harold Johansen	1 point

GO FOR THE GOLD???

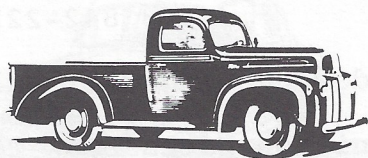

Ford Fact

The new 1932 V-8, for all its brilliance, had little opportunity to recapture Ford's position in the low-priced field. Had the V-8 appeared in the fall of 1931 in full production, the story might have been different. By the end of 1932, in that fast-changing styling time, the Model 18 was seen as already outmoded. It was to be the first Ford car in which body dies lasted only one season.

*Presented by the
Early Ford V8 Foundation*

THE VALLEY V8'S BIG SUNDAY SOCIAL

The location was fantastic, the cars were beautiful, the people were good friends, buddies, and great company, the weather was perfect, and the food was good. We could not of had a better setting for a Sunday Social. Thank you Marsha & Joe Di Fatta, for letting the V8ers enjoy your beautiful home, and for all the hard work you did to make this a great SUNDAY SOCIAL. Also thanks to Lin & John, Lesley & Jerry, Don, Chuck, Dennis, Jackie and Patti for helping out and to all the others that volunteered.

The appetizers, salads, side dishes & dessert were great, it seems like we had plenty enough food to go around.

We ended up having 90 guests and 31 early Fords. There were 14 door prizes, and some very nice raffle gifts. Our trophy committee picked Bob & Karen Reeds 1951 Linc. as the winner. Barbara & Howard Simpson came all the way from Julian, which is down near San Diego. to be with us and brought with them one of our raffle gifts from C&G, THANKS. I also would like to thank the Ventura Club for joining with us, they are such a great bunch to be with.

To those of you that weren't able to make, you missed a good one this time.

THANKS again Marsha & Joe for everything from all us V8ers.

Dick Smith

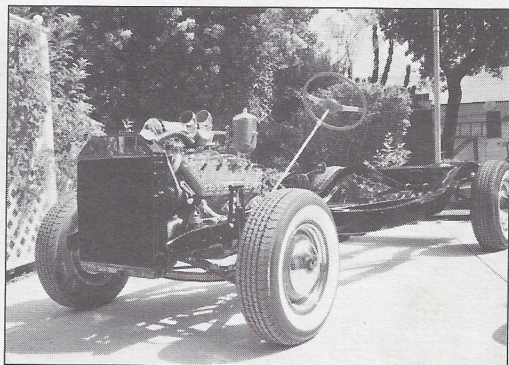



FUN and

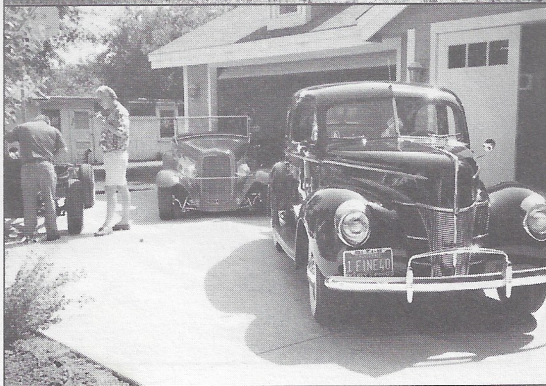
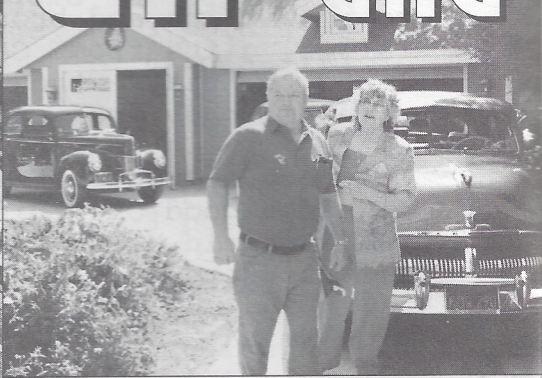
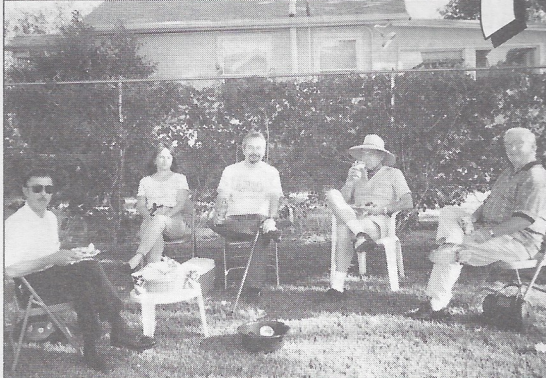

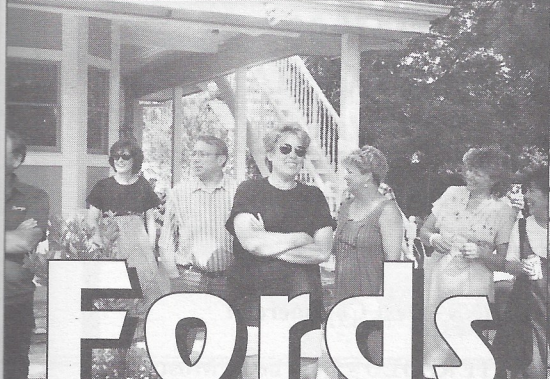
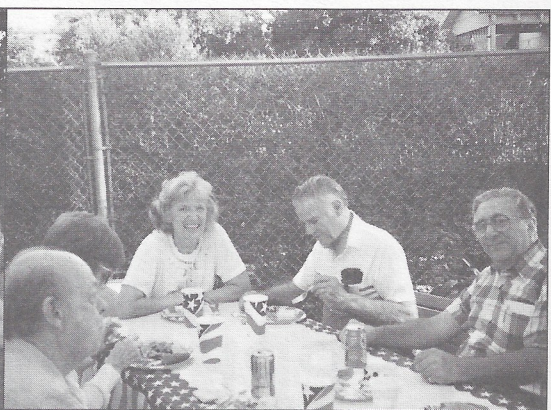

Fords

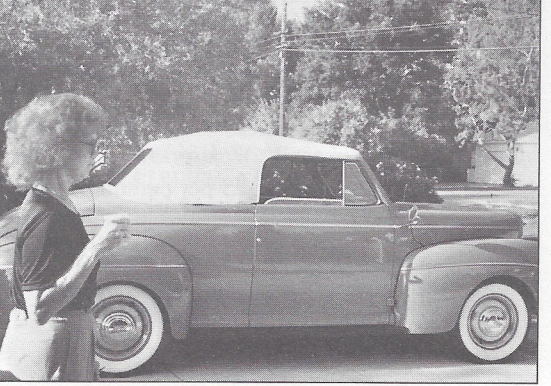

Early Ford V-8 Club of America

Ventura

Valley V-8's

San Diego

Southern California

Santa Maria Valley

Central Coast V-8

Baldy View

Atascadero

ELEVENTH ANNUAL

PEPPERMILL BRUNCH

Sunday, September 22, 1996
795 EAST WALNUT, PASADENA

**ALL WOMEN
JUDGING TEAM**

**VALUABLE
RAFFLE PRIZES**

**GIFTS FOR
EVERYONE**

- | | |
|----------|---|
| A | THE HUNK - Best of Show |
| W | THE CHIPPENDALE - Best Convertible |
| A | THE BEKINS - Best Commercial |
| R | THE CENTERFOLD - Best body Most fun |
| D | THE FONZ - Best Street Rod or Custom |
| S | THE NERD - It needs help |

Tire Kicking Begins 9 a.m · Doors Open 10 a.m · Brunch Served 10:30 a.m.

Mail to arrive by September 19 to:

David Sanborn
8925 White Oak Avenue
Northridge, CA 91325
818/709-0741

Yes, I will attend PEPPERMILL BRUNCH on September 22, 1996

Please make check for \$9.75 per person payable to PEPPERMILL BRUNCH

Name _____ Phone Number _____ Regional Group _____

Tickets will be held at the door and can be picked up after 9 a.m.



AUGUST V8 Birthdays



August 3	Carole Jensen
August 3	Lloyd Paschell
August 4	Christine Varney
August 5	Grant Lippert
August 5	Tom Sawyer
August 11	Mary Finley
August 11	Bridget Winnett
August 12	Julie Ochsner
August 17	Carlos Wilhelm
August 19	Gene Wilson
August 23	Vicki Keene
August 25	Corrine Nitz
August 26	Judy Vess
August 30	Jack Kelejian
August 31	Suzanne Chase

WELCOME NEW MEMBERS!

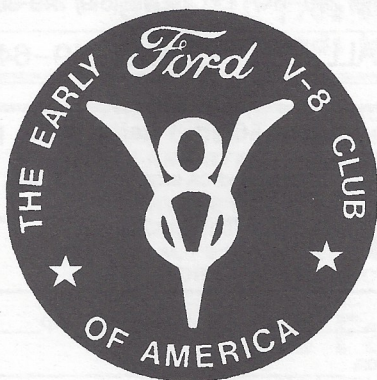

*Don & MaryAnn Coyle
351 Fairview, Arcadia
(702) 299-7241
'67 Ford Mustang*

*Angelo & Vivian Tartaro
10000 Swinton Ave., No. Hills
(818) 894-1555
'49 Ford Coupe • '29 Ford Model A
'60 Cadillac Coupe DeVille*

*Ken & Dottie Schmelzel
18130 Keswick St., Reseda
(818) 996-6118
'50 Mercury*

Be sure to add them to your roster book!



**OPEN TO ALL PRE 1973
AMERICAN CARS, TRUCKS
(STOCK, RESTORED, AND
CUSTOM) AND SPECIAL
INTEREST**

**Portion of proceeds go to the
"MAKE A WISH FOUNDATION"**

**Saturday, August 17, 1996, Park Dr.,
Wrightwood, CA**

**Registration - 7:00 AM to 10:00 AM - Show ends at 4:00 PM
No Cars eligible for awards after 10:00 AM**

*** FREE SPECTATOR ADMISSION * GIANT RAFFLE * 50/50 * VENDORS *
MUSIC * FOOD * GOODIE BAGS * EVENT T-SHIRTS * DASH PLAQUES *
TROPHIES * MISC. PRIZES * 1 FREE RAFFLE TICKET ***

Pinstriping by Van Dervort

NO TRAIERED VEHICLES - NO MINIS - NO ALCOHOL - NO REFUNDS

**FOR INFORMATION OR BED & BREAKFAST, MOTELS, RENTAL CABINS, OR CAMPGROUND FACILITIES CALL (619) 249-4320
FOR MORE CAR SHOW INFORMATION CALL: BETTYE (619) 249-6471 OR IRENE (619) 249-3876**

LIMITED VENDOR SPACE AVAILABLE - CALL: BETTYE (619) 249-6471

**Pre-Registration includes: Goodie Bag - Dash Plaque - Event T-Shirt, 1 Raffle Ticket, plus a
Special Drawing (limited to the first 200 Cars)**

**COST - \$20.00 Pre-registered, \$25.00 at the gate. Mail to Bettye Forsythe, P.O. Box 1385 Wrightwood, CA 92397, by July 17, 1996. Make all
checks payable to WRIGHTWOOD CHAMBER OF COMMERCE.**

Please Print Clearly

PRE-REGISTRATION FORM

Name _____

Signature _____

Address _____

City _____ State _____ Zip _____

Phone _____

Club/Association _____

Vehicle (Year & Make) _____

T-Shirt Size S M L XL XXL XXXL

(Circle one. Add \$2.00 for size XXL and XXXL)

In consideration of the acceptance of participation in, the event sponsors, Wrightwood Chamber of Commerce, by execution of this entry form, I hereby release and discharge the event sponsor, Wrightwood Chamber of Commerce, and it's directors, officers, employees, agents, representatives, and servants, and anyone else connected with management of conduct of and from any and all known and unknown damages, injuries, losses, judgement and/or claims from any causes whatsoever that may be suffered by any members to his person or property, further, each applicant expressly agrees to indemnify all the foregoing entities, firms, persons, and bodies of and from any and all cooperating with applicant and under direction or control of the applicant.

The John Burroughs High School 9th Annual

CAR SHOW



Sunday, September 8, 1996 • 10:00 a.m. - 3:00 p.m.

John Burroughs Memorial Stadium

1920 West Clark Street, Burbank • Enter on Keystone Street

Admission: Adults-\$5.00 • ASB Member, Children(10-16)-\$2.00

Under 10 Free • Great Food, Drinks and Cars

All Proceeds to benefit Football Program

**AWARDS FOR STOCK AND MODIFIED CLASSES: CARS, TRUCKS, MOTORCYCLES
CAR CLUB PARTICIPATION AWARD • CLUBS MUST ARRIVE TOGETHER
PRE-REGISTER FOR FREE T-SHIRT • DASH PLAQUE TO ALL ENTRIES
LIVE D.J. MUSIC, PRIZES AND FOOD**

**ENTRY FEE PER VEHICLE: PRE-REGISTER \$20.00 MUST BE RECEIVED BY
AUGUST 30TH, DAY OF SHOW \$25.00 ENTRIES MUST ARRIVE BETWEEN
7:00A.M. - 9:00A.M. SEPTEMBER 8TH • VENDOR SPACE AVAILABLE \$40.00
CALL FOR GENE KENDRICK (818) 843-2363 (HOME) (818) 777-2471 (WORK)**

Ford Fact

**On April 29, 1941, Ford
builds it's 29 Millionth
Ford vehicle.**

*Presented by the
Early Ford V8 Foundation*

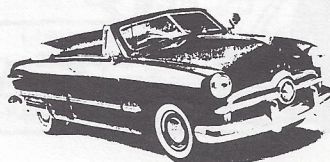



WHO IS THIS???

CLUES:

- Photo taken 1949
- He now has Gray Hair
- He drove a Blue vehicle to our last meeting!!
- A member for over 20 years



Answer will be given at our Aug. 20th meeting.

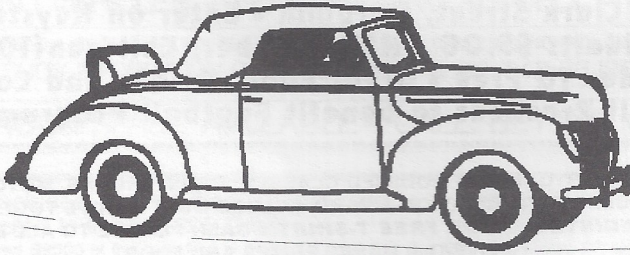

SHOE



© 1996 Tribune Media Services, Inc. All Rights Reserved

WAPREZ

6/1

SUPPORT OUR ADVERTISERS!

Chatsworth Auto Upholstery

Classics • Hot Rods • Foreign & Domestic

JIM ORTUNO
(818) 882-5161

21300 DEVONSHIRE ST.
CHATSWORTH, CA 91311

FLIP SMITH



7735 SEPULVEDA BOULEVARD
VAN NUYS, CALIFORNIA 91405

Bus: (818) 786-8686

Fax: (818) 785-2982

DON'S Auto Parts

MACHINE SHOP and BALANCING

Monday thru Friday 8 a.m. to 7 p.m.
Saturday 9 to 6 - Sunday 10 to 4

10241 Woodley (At Devonshire)

Domestic &
Foreign

Parts & Supplies



(818)
894-6441

Sepulveda, CA 91343

RAFFLE PRIZE DONOR

LESLEY A. LITTNER
(818) 597-9016 / FAX:597-9145

BOOKKEEPING & BUSINESS SERVICES

5051 BLACKPOOL AVE.
AGOURA, CA. 91301



Older Cars
A Specialty

4 x 4's and
Motorhomes

Russell Sylvis, Inc.

Transmissions
Repaired • Rebuilt

(805) 527-4387

4657 Barnard St.
Simi Valley, CA

R.C. Smith's Roofing Solutions

Roofing & Waterproofing • Complete Maintenance Service

8707-D Lindley Ave., Ste. 199, Northridge, CA 91325
Lic. #356650 (818) 718-2313

Auto • Homeowners

- ANTIQUE CARS -

ED HARDIN INSURANCE

Business • Life • Health • Aircraft



Call us for your Insurance needs!

(818) 363-7864

ALLAN FRANKLIN'S BATTERY TENDER

\$59.99

club members
\$54.99

Charges battery up and turns itself off
automatically when it fully charged.

Takes the guess work out of battery maintenance!

(818) 842-2230

6, 8, or 12 Volt Models

SUPPORT OUR ADVERTISERS!

L.T. "LEE" SAWYER, INC.

Jobber

Shell Oil and Chemical Products

14117 Aetna Street, Box 369
Van Nuys, California 91408

TOM SAWYER (818) 786-8180 / (818) 785-0902

RAFFLE PRIZE DONOR

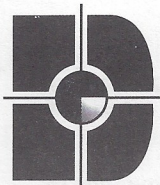

**DiFATTA
GRAPHICS**
Incorporated

Joe DiFatta

Chief Executive Officer

27642 Avenue Hopkins
Valencia, California 91355

Phone: 805 295-8788
800 990-1939

Fax: 805 295-5069
Modem: 805 295-5119

CHEVY AND FORD TRUCKS • 4 x 4
55-56-57 CHEVY CARS 67-87 CAMARO 64-87 CHEVELLE
NEW AND USED PARTS

*American Auto & Truck
Dismantlers*

12172 Truman St. • San Fernando, CA 91340
(at Hubbard) **ROGER** (818) 365-3908

RESIDENTIAL • COMMERCIAL • INVESTMENT



Spencer Realty

3948 Goodland Ave.
Studio City, CA 91604
Office: 818-761-1734
Fax: 818-761-7952



AL SPENCER

QUALITY PROFESSIONAL SERVICE



John Mangiapane
(818) 994-5077

14743 Keswick Street
Van Nuys, CA 91405

Low prices
Repiping Specialist

Commercial & Residential
All Drain & Plumbing Needs

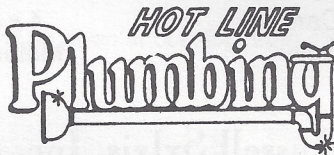

(818) 315-8601
State Contractors Lic. #682431

JED

Did You Know?

So you think those rear wipers you see on all the hatchbacks and wagons today are a recent development? Hardly. This innovative "seesaw" rear wiper system was developed in the thirties for those vision-robbing splitrear windows so much in vogue back then. Sadly, it was never adopted for use by a major manufacturer. Greater Pittsburgh Reg Grp

What's A Tune-Up? Does anyone really know?!

We all know the complexity of today's modern cars has changed the definition of a "tune-up" forever. The mechanical adjustments of yesterday with points, condenser, carburetor, valve lash and regulators have given way to thousands of computer complexities. But is today's technology causes a mechanic confusion, just think how a motorist feels. The gas-n-go motorist doesn't know "what", let alone "why".

Today's tune-up is a combination of diagnosis, adjustment and maintenance. Keeping cars in optimum working condition requires a check of all engine performance controls and systems. It also includes adjustments to bring the vehicle into proper running condition. Note that the tune-up involves the checking of CONTROL systems; the electronic and fuel injection controls. There is nowhere near the mechanical adjustments needed or required on the modern cars. If a component needs attention, it is merely removed and replaced without adjustments or repairs.

From Borg-Warner Automotive and some additions from Don Cunningham of The Bif Valley V-8 Rumble

A comment on the above from Motor's Magazine: Older engine work is satisfying. You can get right in there and observe the parts, then actually see and feel the results of your restoration efforts. The makes these jobs completely different from electronics diagnosis and repair, which involve invisible, mysterious goings on the don't respond to the experienced touch of a craftsman.

PAST PRESIDENTS

JIM ROWE.....	1971
DOUG PETERSON.....	1972
DON DURKEE.....	1974
ED WARNOCK.....	1975
JOHN BUSK.....	1976
CHIP WERSTEIN.....	1977
STAN MARSRAJE.....	1978
BOB DRAKE.....	1979
BILL CULP.....	1979
AL SPENCER.....	1980
LARRY CAPLAN.....	1981
BOB ROSE.....	1982
DON DURKEE.....	1983
PAUL KIRK.....	1984
KENT LOWRY.....	1985
DAVE SANBORN.....	1986
JOHN KEMMERER.....	1987
DUDLEY OCHSNER.....	1988
JERRY JENSEN.....	1989
JERRY JENSEN.....	1990
JOE DIFATTA.....	1991
CHUCK SHUBB.....	1992
CHUCK SHUBB.....	1993
GEORGE RICHARDS.....	1994
JERRY LITTNER.....	1995

Meetings are held on the first Sunday of every month at 7:00 p.m.

The Valley 's

10532 GERALD AVE., GRANADA HILLS, CA 91325

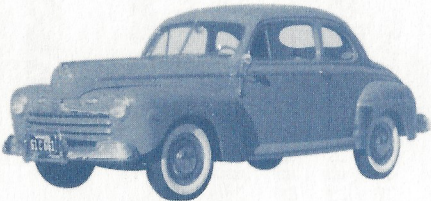
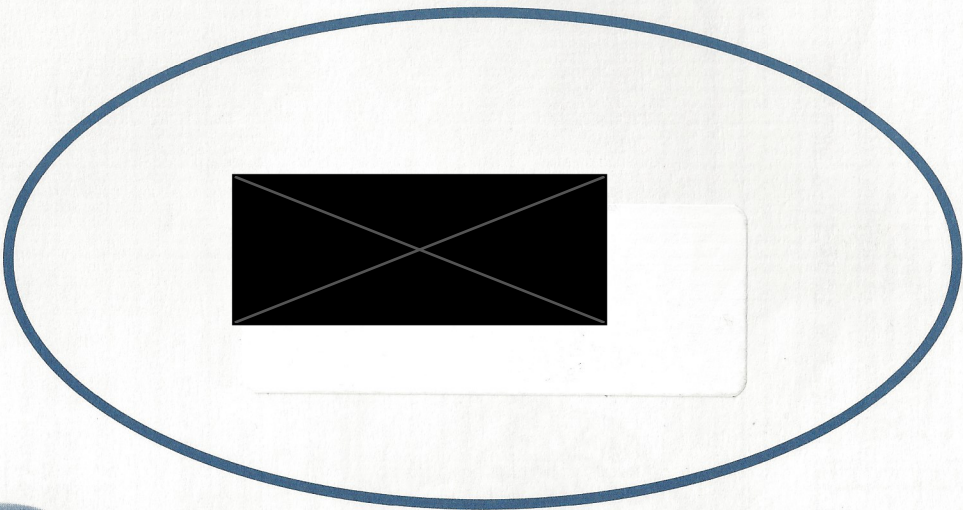

1946 Ford Coupe