

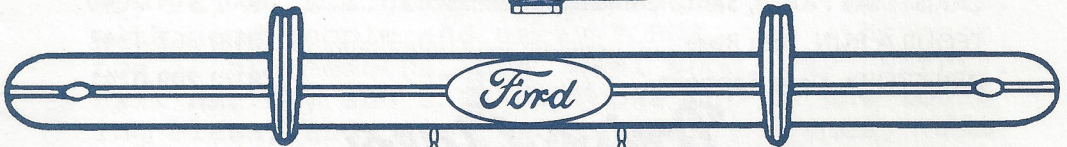

SEPTEMBER

## Our 25th Year

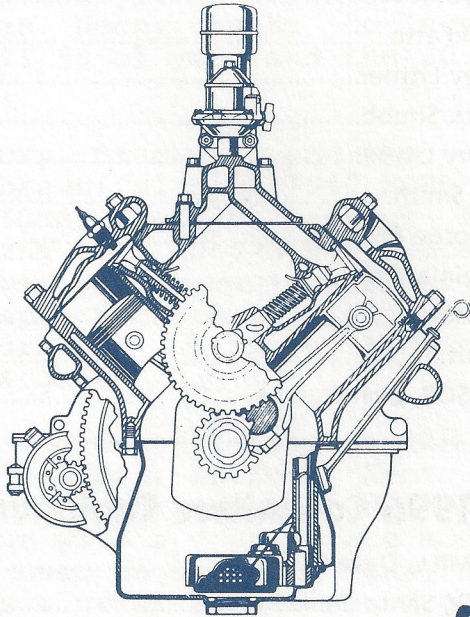

San Fernando  
Valley s  
CHAPTER 40

# Drive Lines

# The Valley 's

---

## 1996 OFFICERS

PRESIDENT, Dick Smith.....	(818) 368-5890
VICE PRESIDENT, John Wolf.....	(818) 789-6201
SECRETARY, Joe DiFatta.....	(818) 700-1939
TREASURER, Lesley Littner.....	(818) 597-9016
PROGRAMS, Chuck Shubb.....	(818) 882-2927
ACCESSORIES, Jerry Littner.....	(818) 597-9016
HISTORIAN, Patti Smith.....	(818) 368-5890
MEMBERSHIP, George Richards.....	(818) 992-4537
FELLOWSHIP, Virginia Wolf.....	(818) 789-6201
RAFFLES, Chuck Mair.....	(818) 785-9413
EDITOR, Don Stout.....	(818) 998-7054
TECHNICAL ADVISOR, Don Durkee.....	(805) 495-5298
TOUR MASTER.....	EVERYONE

## 1996 Committee Chairmen

ANNUAL PEPPERMILL, Dave Sanborn.....	(818) 709-0741
CHRISTMAS PARTY, Santa Claus.....	(800) SANTA 40
TEQUILA RUN, Bob Rose.....	(818) 362-4842
DIRECTORY, Dave Sanborn.....	(818) 709-0741

## *Drive Lines*

Published By

SAN FERNANDO VALLEY CHAPTER 40  
of the EARLY FORD V8 CLUB OF AMERICA

P.O. Box 96  
Reseda, CA 91335

# PRESIDENT'S MESSAGE

September 1996

## THE VALLEY V8'S 25TH ANNIVERSARY YEAR

Hello Fellow Club Members:

We had a great turn out for our last meeting on August 20th, being a different night and for as hot as it has been, thanks to everyone that showed up all 55 of you, and the 20 early FORDS you came in.

Gerry & Blacky Blackwell won the August trophy with there beautiful Blue 1940 FORD convertible CONGRADULATIONS. The \$20 Jackpot for the name badge drawing was not given, because he (and I can remember who it was), was not wearing his badge, so September 3rd meeting the JACKPOT for name badge drawing will be \$40, so wear your badges guy & gals.

Patti and I had a great time on the Jay Harris tour to the Western National Meet in Victoria British Columbia Canada. We had 17 early FORDS, on the tour with a couple late models. If you have never been on a Harris Tour, you should try it, it's a great way to spend your vacation, with good people and early FORDS. At the meet the tour members did real good, Jay Harris, Bill Harvey, and Dave Caparone won in the touring class, and Jim Little, Jerry James, Jim Miller and myself won in the Dearborn class, and Dan Mc Cue won in the display class. Thanks again Jay and Sylvia for all the hard work it takes to make such great Tour, you can count Patti and I in for next year to Rohnert Park.

Hope to see all of you at September 3rd meeting and at the PEPPERMILL TOUR on the 22nd of September.

Yours Truly,

Dick Smith

# Valley V8 MEETING

*Tuesday September 3rd 1996*

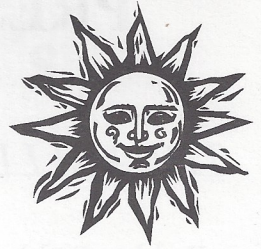

**Weiler's New York Style Deli  
Restaurant • Bakery • Catering  
16150 Nordhoff Street  
North Hills, CA**

(818) 892-8663 • Fax (818) 894-2443

6:30 PM PARKING LOT TIRE KICKING & VISITING  
& Dinner if wanted, the food is good.  
7:30 PM MEETING STARTS

GREAT PROGRAM FOR THE EVENING, Cal Beauregard will be our September Program with "Highlights of the Ford Company Era".

Two ladies in attendance will receive a door prize.

The Trophy for the September 3rd Meeting will be given to a early FORD 1932-53 product in the parking lot, to be chosen by George Richards, Jerry Jensen, and Chuck Shubb they are the judges, so bring your cars.

The name badge drawing (JACKPOT \$40.00), to be given to a club member in attendance that is wearing their badge.

Early FORD's driven to any Meeting, Tour, or Events will receive points, at the NOVEMBER MEETING, the member who has the most points will WIN a \$100.00, and 2nd place will WIN \$50.00.

# SECRETARY'S REPORT

by Joe DiFatta

Well, we made it back from the "Ford and Flowers" tour ... all except CHUCK MAIR. Seems like his '41 blew a valve seat.

We still had a lot of members and guests at the August 20th meeting. Twenty Fords in the parking lot, even got my '48 Ford all cleaned up for the meeting.

Ladies raffle was won by ROSE GOTT and my granddaughter 'JENIFER'. She was PATTI SMITH'S helper for the ticket sales. GEORGE RICHARDS presented BLACKIE BLACKWELL a trophy for the best looking car on the lot. He and Gerri drove their '40 convertible.

PRESIDENT DICK SMITH stated that in October, we will have an open meeting for the election of officers for 1997. One lady member of our club has announced she will not except the nomination for president ... what about her husband??? He is retired and never been President.

JACK MILES spoke about his early cars and handed out pamphlets on Stromberg "97" Carburetors. Jack also mentioned he was one of the original members in our club to design and format our "Drivelines". I would like to hear more about that ... plus Jack has never been President of our club and he is retired!!

PRESIDENT DICK got himself, DONNA and LLOYD PACHAL (Lloyd has never been President), GERRI BLACKWELL and myself to speak about our trip to the "Ford and Flowers" tour in British Columbia. Here's the summary:

18 cars / 17 mechanics / DICK SMITH / 2 coils / 1 distributor / 1 oil sending unit / 1 water pump (2 times) / 1 carburetor / couple of overheats / 3000 miles / \$900.00 richer / great picnics in the parks / sightseeing at Mt. Hood / Lava Beds / Tour of Sportsmens Wood Shop / Great display of 300 Fords / and lots of fun ... etc... etc...

That's it for now "CIAO!"

*New Valley V8  
Mailing Address*

**P.O. Box 4033  
Chatsworth, CA 91313**

**Sharing a Bathroom  
with Someone  
Requires a lot of Love**

**- 1st Lady, Patti Smith**

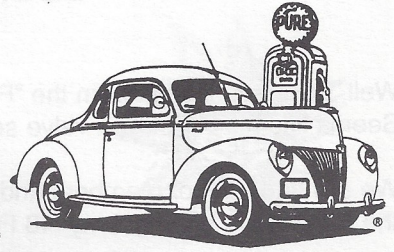

## Editor Says.....

Another busy month with lots of activities and the mid-month meeting. The last straggler arrived from the Victoria Isle tour Sunday. Chuck had his share of problems, but found help in Oregon and drove his 1941 home with the recommendation he look for a new engine -- Anyone that has a spare should contact Chuck Main. The meeting was well attended; Seems like I was the only one with a schedule conflict.

September/November will complete the tour season with a bang! Mexico sign-ups overdue, Sequoia trip see Gerri Blackwell and the Peppermill brunch are all enclosed.

All reports are Hot August Nights was once again a huge success in Reno, I understand Las Vegas has plans on the horizon for some competition with a Fall Classic.

Once again, not too much to report on my restoration, seems to be in the doldrums, but the word is one of our President's Fords may change colors.

Keep the articles coming.

Don Stout  
(818) 782-4604

Ed

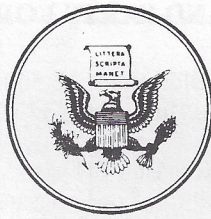

Office of the President  
Bill Clinton  
1600 Pennsylvania Ave. N.W.  
Washington, D.C. 20500

Hi Joe,

Thanks for sending me the August copy of the "Drivelines". Hillary and I were planning to attend the Western Ford meet in British Columbia, but got sidetracked watching those two old guys speaking in San Diego ... They think this job is easy!!! I even had thoughts of dumping V.P. Gore and making Hillary our new V.P., frankly we could use the money. I even had it planned to join the Jay Harris Tour in my '65 Mustang. I noticed you didn't have a Secretary's Column last month ... you probably wonder if anyone ever reads the "Drivelines".

After getting your note about President Dick Smith removing your name and points from the November contest, I'm convinced something is fishy. Since he has been your club president, I feel you have your own "White Wash" dilemma. I'm sending the information to the F.B.I. and Secret Service for a complete investigation and audit. We actually had Jim Miller from the Secret Service in his red '41 Ford truck on the Jay Harris tour checking on Dick Smith's "Whereabouts". We just can't believe he washes and waxes his car that often.

I saw the video showing the 18 cars going up Highway 395. Really neat, even that part where you were changing the distributor and coil and doing repairs. I even got a report from the I.R.S. about Gerry Blackwell winning over \$900.00 on the slot machine in Tahoe. It was nice of her to buy everyone pizza in Alturas. (Tax deductible you know). I notice that President Smith showed up in a tie and jacket, ate his pizza and disappeared again!! I also heard during the trip he bought extra luggage to take home all of the new bath towels he said he "purchased" with the "Super 8" logo on the towels.

Well, I'm off to Chicago by train, hopefully all is well, till next time.

Bill Clinton

P.S. How's your new water pump and I heard that Chuck Mair is finally home.

## CARS AND PARTS FOR SALE

'68 Oldsmobile \$3,500.00  
Elaine Hunt (310) 337-2372

'27 T-Roadster PU with V8-60  
John Walsh (818) 249-8911 or Ken Sapper (818) 362-5865

4 - 670 x 15 Bedford WWW Tires  
Joe DiFatta (818) 700-1939

'67 Mercury Cougar XR7, 84,000 miles one owner, A-1 Condition, \$7500.00  
Mary Jane (818) 784-9681

'50 Chev. PU 3 Windows, 3 speed standard Trans., 84,000 Original Miles, Very Clean \$3,995.00  
Glen Jarrell (916) 529-6433

## CARS & PARTS WANTED

'48 Water Pump, left side, Joe DiFatta (805) 295-8788

Need '41 - '48 Ford Engine Complete, Chuck Mair (818) 785-9413



## SEPTEMBER V8 Birthdays



Sept. 6 Suzanne Case  
Sept. 7 Tomy Thompson  
Sept. 11 Patti Smith  
Sept. 13 Ann Caplan  
Sept. 15 Martin Luening  
Sept. 16 Barbara Simpson  
Sept. 18 **President Dick Smith**  
Sept. 20 Bob McCullagh  
Sept. 26 Harriette Kawelmacher  
Sept. 28 Bill Carpenter



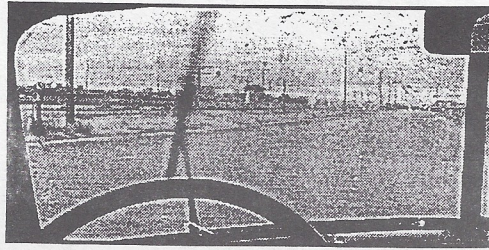

## "LOOKING AHEAD"

SEPTEMBER 3rd 7:30 PM Meeting at Weiler's  
TUESDAY come early for tire kicking and  
dinner.

SEPTEMBER 22nd Eleventh Annual PEPPERMILL  
SUNDAY BRUNCH, Doors open at 10:00 AM

OCTOBER 1st 7:30 PM Meeting at Weiler's  
TUESDAY come early for tire kicking  
and dinner.

OCTOBER 20th 9:00 AM Meet at Woodley Park  
SUNDAY TOUR to Art Astor's

NOVEMBER 5th 7:30 PM Meeting at Weiler's  
TUESDAY come early for tire kicking and  
Dinner.

DECEMBER 1st THE CHRISTMAS PARTY at the  
SUNDAY SMOKEHOUSE 6:30 PM.

## WELCOME NEW MEMBERS!

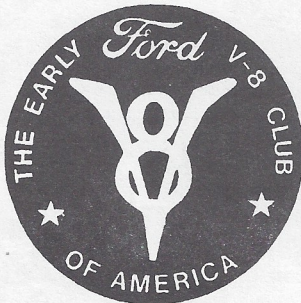

Gary's Glass  
935 Mission Terrace  
Camarillo, CA 93010  
(805) 499-2587

'36 Ford 2 Door

*Be sure to add them to your roster book!*



# Jay Harris T

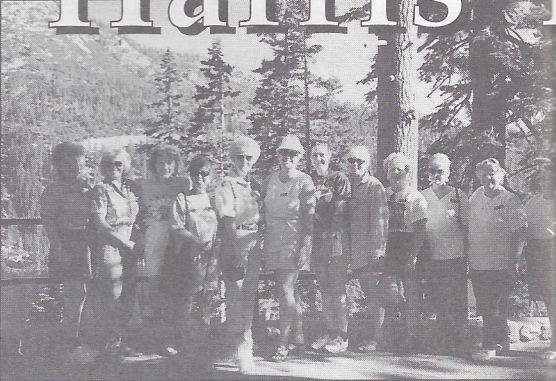
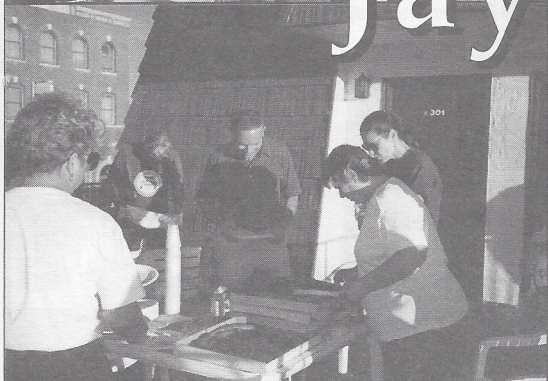

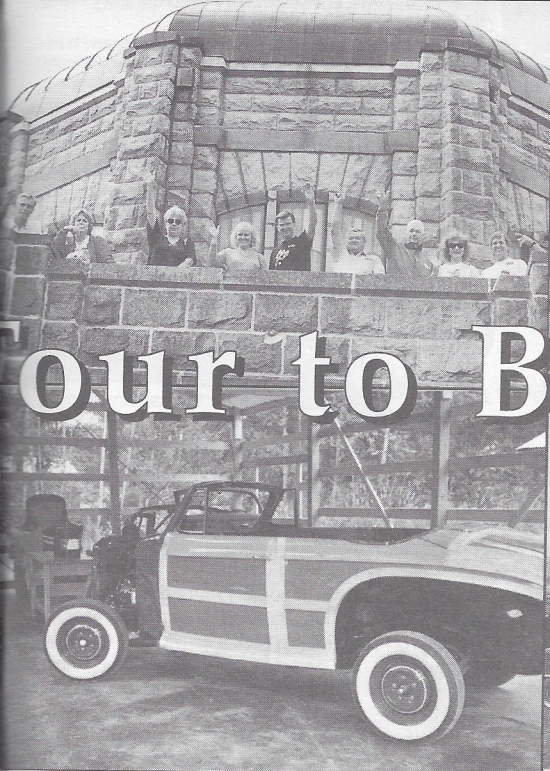

# our to B.C.

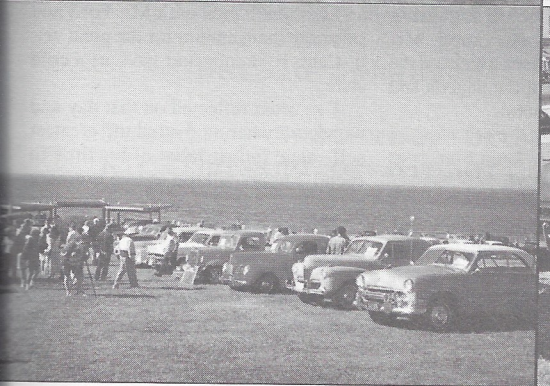

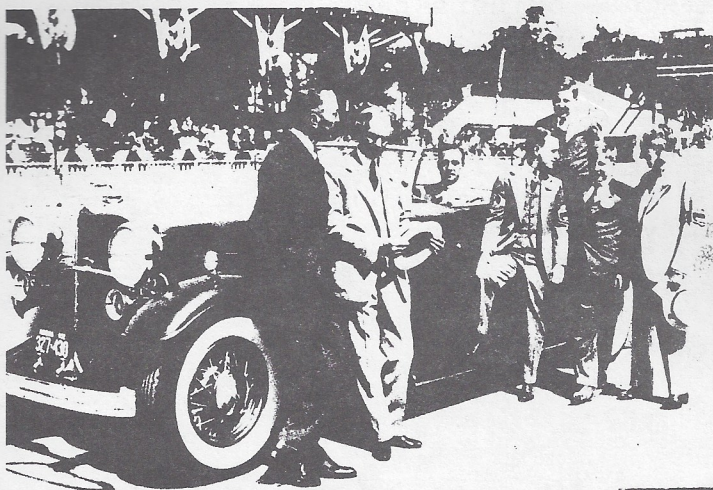

# We Watched 'Indy' With Henry Ford

*When two teenagers sneaked into the big race, they found themselves in some unexpected company.*

*By Richard Palmer, Cortaro, Arizona*

MY FRIEND WALLY and I often played hooky from Shortridge High School in Indianapolis during the month of May so we could go to the track and watch the race cars. But our most memorable trip to the track was on a school holiday—Memorial Day 1932.

Wally's grandfather was a contributor to the Speedway, and he had a "distinguished pass" for entry through the front gate and admission to the "pagoda", a five-story structure reserved for the press and VIP's.

That year, Wally's grandpa wasn't able to attend the race, so he offered the pass to Wally, who eagerly accepted it. At the track, Wally entered through the main gate, then met me at the fence and slipped the pass to me.

The pagoda was more of a challenge—each level had a guard at the door. But since each floor had a balcony, Wally could get up to one level, lean out over the railing and lob the pass down to me.

By noon, we'd made our way to the top floor, where about 20 people were congregated in a small area.

And what a congregation it was! The host was Capt. Eddie Rickenbacker, World War I ace, former "500" driver and owner of the Speedway. His guests included Harvey Firestone and his son and Edsel Ford and his sons, Henry Ford II and Benson.

## Great Man Arrives

Around 12:30, I heard a guard's voice boom, "Good afternoon, Mr. Ford." Henry Ford himself ascended the final steps to the top of the pagoda and tipped his hat to the guard.

Nearly 69 then, Mr. Ford was the picture of health. His keen blue eyes stopped on Wally and me.

Capt. Rickenbacker stood, greeted Mr. Ford grandly and offered his seat. But Mr. Ford replied, "Eddie, you go ahead and enjoy the race. I'm going over there and talk with these two young men."

I detected a disappointed look on Capt. Rickenbacker's face as Mr. Ford approached us, removed his straw hat and stuck out his hand. "Good afternoon," he said politely. "My name is Henry Ford."

His first question was how we got to the top floor of the pagoda. When we explained how we'd dropped our one pass from floor to floor, Mr. Ford laughed heartily and said, "It's a good thing it isn't a windy day."

The three of us chatted for 2 hours! Mr. Ford especially liked the story I told

**BIG WHEELS.** Eddie Rickenbacker and Henry Ford consulted (left). Years later, Richard Palmer (below left) was back at the Speedway.

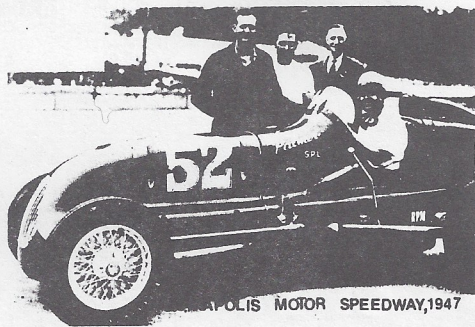

about seeing an old Model T "Tin Lizzie" motoring right past newer cars stalled by muddy ruts on a country road.

Every so often during our conversation, Capt. Rickenbacker would rise and offer Mr. Ford his seat. But each time, Mr. Ford politely refused, saying he was enjoying himself. Capt. Rickenbacker would turn back with a glum look on his face, and disappointment showed clearly on the faces of his other guests.

When the race was almost over, Capt. Rickenbacker suggested Mr. Ford join him in the winner's circle. Wally and I shook hands with Mr. Ford and sincerely thanked him for the great visit. Capt. Rickenbacker gave us a cold stare.

I've often reflected on that day and wondered what motivated the greatest self-made industrialist of his time to spend 2 hours talking to two ordinary teenagers.

**Editor's Note:** Years later, Richard Palmer returned to the Indianapolis Speedway legally and officially. He and his father built and owned cars that raced there.

The following cars and drivers have points towards the November JACKPOT

**	Lin & John Kemmerer	12 points
****	John & Virginia Wolf	14 points
	Al Rohrer	10 points
***	Patti & Dick Smith	13 points
	Dick Stone	10 points
*	Gerry & Blacky Blackwel	11 points
**	David & Rose Gott	12 points
	Geroge Richards	7 points
*	Lloyd & Donna Paschal	11 points
	Jerry & Lesley Littner	8 points
	Jerry & Carole Jensen	8 points
	Don & Mary Durkee	5 points
	Ken Sapper	2 points
	Judy & Chuck Schubb	6 points
	Richard Valleroy	8 points
	Wayne Burns	4 points
	Ed Hardin	1 point
	Bill King	1 point
	Richard Chutuk	1 point
	Bob Rose	1 point
	Cal & Nancy Beauregard	1 point
	Vicki & Dennis Keene	3 points
	Chuck Mair	6 points
	Steve & Sue Boskovich	4 points
	Carlos Wilhelm	2 points
	Allen Franklin	1 point
	Dave Sandborn	2 point
	Bob & Jackie Monnick	4 points
	Leslie Mac Willie	3 points
	Don & Cheryl Stout	1 point
	Ken & Dottie Schmelzel	6 points
	Larry & Ann Caplan	1 point
	Howard & Barbara Simpson	1 point
	Bob Reed	3 points
	Harold Johansen	1 point

Tuesday, September 3rd Meeting 6-6:30 PM Tire Kicking and or dinner, Weiler's" Restaurant, 7:30 meeting will comes to order.

Sunday, September 22nd Eleventh Annual PEPPERMILL Brunch, meet at Woodley Park at 9:00 AM & will leave at 9:15 AM.

**EARLY FORD V 8 CLUB OF AMERICA**  
**Ensenada, Mexico Tour**  
*All Chapters Welcome*  
**September 27, 28, 29, 1996**  
**Limited to the First 25 Cars**

Meet in San Diego Friday noon at Burger King (take Rosecrans exit form either the 8 or 5 freeway, first left is Kurtz, one way, 1 block to Burger King) for a lunch stop). Then over the bridge to Coronado, down the Silver Strand to the border. We will regroup and cross the border going around Tiajuana to the Coastal Toll Road to Ensenada, approximately 70 miles. We will spend Friday and Saturday Night at the Travelodge, where our Early Ford V8's will be parked in the courtyard, locked in with a Security Guard at night.

At 6:00 p.m. a Margarita Hour will be hosted by the Hotel, followed by dinner at 7:00pm across the street at the El Rey Sol Restaurant. After dinner, perhaps a stroll to Hussongs Famous Cantina.

Saturday we can tour south to La Buffadura (the Blow Holes) and still have plenty of time for shopping in the Afternoon and dinner on you own at one of the many good Restaurants..

Sunday after breakfast, we tour north to San Diego with perhaps a stop at the Historic Rosarita Beach Hotel, crossing the border about Noon.

Mexico liability Insurance will be included in the Tour package. Be sure you have your **current car registration** and a **current driver's license** with you. This information and verification is required for the Mexican Rider Liblity insurance.

- Cost:                   2 Nights including Tax and a Guard
- 1 Dinner including Tax and Tip
- Liability insurance from
- Noon Friday until Noon Sunday
- 2 Margarita Hours

Total Cost \$150 Per Couple

**Reservations must be received by September 1, 1996, we have room for 25 cars and 50 people. First come, first serve.**

**FOR FUTHER INFORMATION, PLEASE CALL, FAX OR WRITE TO:**

Early Ford V8 Club Mexico Tour Lee A. Chase  
601 Lorraine Blvd. Los Angeles, CA 90005  
Phone (213) 938-4601 Fax: (213) 933-5310

Complete the informataion requested, and attach your check made payable to Ford Tour Mexico and mail to address above.

-----CUT-----CUT-----CUT-----CUT-----CUT-----

Name \_\_\_\_\_ Phone no. \_\_\_\_\_

Address \_\_\_\_\_

Driver's license no. \_\_\_\_\_ Car license \_\_\_\_\_

Year of Ford \_\_\_\_\_ Body style \_\_\_\_\_ Vin no. \_\_\_\_\_

Passenger's name \_\_\_\_\_

## EARLY V8 FORDS DRIVEN TO THE MEETING

1937 FORD Slant Bob & Jackie Monnick  
1936 FORD Conv. Richard Valleroy  
1940 FORD 4 door Al Rohrer  
1950 MERC. Ken & Dotti Schmelzel  
1940 FORD Pick-up Rose & Dave Gott  
1932 FORD Rdst. Dick Stone  
1951 FORD 2 door Les Mac Willie  
1950 MERC. J.R. Arena  
1940 FORD Cpe. Gerry & Blacky Blackwell  
1948 Ford Cpe. Joe Di Fatta  
1940 FORD Tudor John & Virginia Wolf  
1940 FORD Cpe. Patti & Dick Smith  
1940 FORD Cpe. Lin & John Kemmerer  
1939 FORD Conv. Shirley & George Richards  
1951 LINC. Bob Reed  
1953 FORD Cpe. Donna & LLOYD Paschal  
1936 FORD Cpe. Joe Simon  
1930 FORD Model A Wayne Burns

The other classic cars driven were,  
Mike Monroe 64 FORD PU, David Satel 60 T-Bird

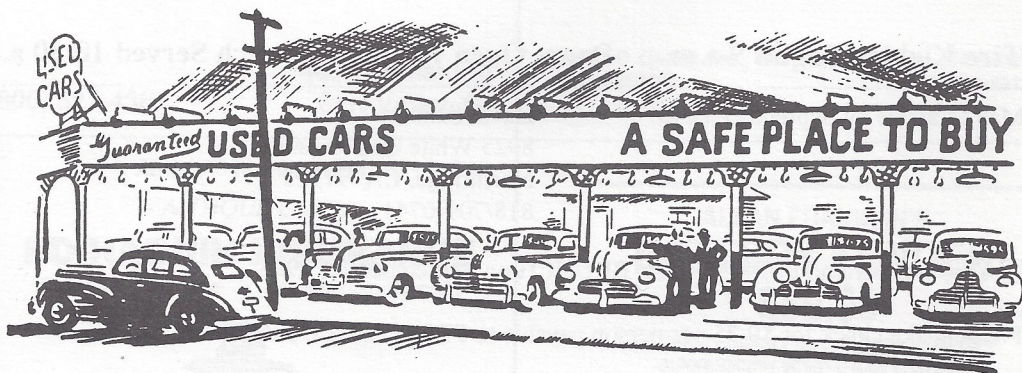

# Early Ford V-8 Club of America

Ventura

Valley V-8's

San Diego

Southern California

Santa Maria Valley

Central Coast V-8

Baldy View

Atascadero

## ELEVENTH ANNUAL PEPPERMILL BRUNCH

Sunday, September 22, 1996  
795 EAST WALNUT, PASADENA

**ALL WOMEN  
JUDGING TEAM**

**VALUABLE  
RAFFLE PRIZES**

**GIFTS FOR  
EVERYONE**

- A** THE HUNK - Best of Show
- W** THE CHIPPENDALE - Best Convertible
- A** THE BEKINS - Best Commercial
- R** THE CENTERFOLD - Best body Most fun
- D** THE FONZ - Best Street Rod or Custom
- S** THE NERD - It needs help

**Tire Kicking Begins 9 a.m. · Doors Open 10 a.m. · Brunch Served 10:30 a.m.**

Mail to arrive by September 19 to:

David Sanborn  
8925 White Oak Avenue  
Northridge, CA 91325  
818/709-0741

Yes, I will attend PEPPERMILL BRUNCH on September 22, 1996

Please make check for \$9.75 per person payable to PEPPERMILL BRUNCH

Name \_\_\_\_\_ Phone Number \_\_\_\_\_ Regional Group \_\_\_\_\_

*Tickets will be held at the door and can be picked up after 9 a.m.*



# SUPPORT OUR ADVERTISERS!

## Chatsworth Auto Upholstery

Classics • Hot Rods • Foreign & Domestic

JIM ORTUNO  
(818) 882-5161

21300 DEVONSHIRE ST.  
CHATSWORTH, CA 91311

FLIP SMITH



7735 SEPULVEDA BOULEVARD  
VAN NUYS, CALIFORNIA 91405

Bus: (818) 786-8686

Fax: (818) 785-2982

## DON'S Auto Parts

MACHINE SHOP and BALANCING

Monday thru Friday 8 a.m. to 7 p.m.  
Saturday 9 to 6 - Sunday 10 to 4

10241 Woodley (At Devonshire)

Domestic &  
Foreign

Parts & Supplies



(818)  
**894-6441**

Sepulveda, CA 91343

RAFFLE PRIZE DONOR

LESLEY A. LITTNER  
(818) 597-9016 / FAX: 597-9145

## BOOKKEEPING & BUSINESS SERVICES

5051 BLACKPOOL AVE.  
AGOURA, CA. 91301



Older Cars  
A Specialty

4 x 4's and  
Motorhomes

Russell Sylvis, Inc.

Transmissions  
Repaired • Rebuilt

(805) 527-4387

4657 Barnard St.  
Simi Valley, CA

## R.C. Smith's Roofing Solutions

Roofing & Waterproofing • Complete Maintenance Service

8707-D Lindley Ave., Ste. 199, Northridge, CA 91325  
Lic. #356650 (818) 718-2313

Auto • Homeowners

- ANTIQUE CARS -

## ED HARDIN INSURANCE

Business • Life • Health • Aircraft



Call us for your Insurance needs!

**(818) 363-7864**

## ALLAN FRANKLIN'S BATTERY TENDER

**\$59.99**

club members  
\$54.99

Charges battery up and turns itself off  
automatically when it fully charged.

Takes the guess work out of battery maintenance!

(818) 842-2230

6, 8, or 12 Volt Models

# SUPPORT OUR ADVERTISERS!

## L.T. "LEE" SAWYER, INC.

Jobber

Shell Oil and Chemical Products

14117 Aetna Street, Box 369  
Van Nuys, California 91408

TOM SAWYER (818) 786-8180 / (818) 785-0902

**RAFFLE PRIZE DONOR**

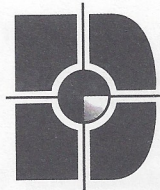

**DiFATTA  
GRAPHICS**  
Incorporated

**Joe DiFatta**  
Chief Executive Officer

27642 Avenue Hopkins  
Valencia, California 91355

Phone: 805 295-8788  
800 990-1939

Fax: 805 295-5069  
Modem: 805 295-5119

CHEVY AND FORD TRUCKS • 4 x 4  
55-56-57 67-87 64-87  
CHEVY CARS CAMARO CHEVELLE  
NEW AND USED PARTS

**American Auto & Truck  
Dismantlers**

12172 Truman St. • San Fernando, CA 91340  
(at Hubbard) **ROGER** (818) 365-3908

RESIDENTIAL • COMMERCIAL • INVESTMENT



*Spencer Realty*

3948 Goodland Ave.  
Studio City, CA 91604  
Office: 818-761-1734  
Fax: 818-761-7952



**AL SPENCER**

QUALITY PROFESSIONAL SERVICE

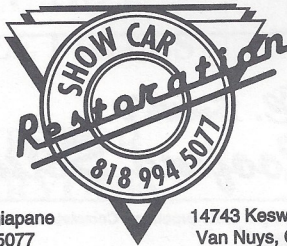

John Mangiapane  
(818) 994-5077

14743 Keswick Street  
Van Nuys, CA 91405

Low prices  
Repiping Specialist

Commercial & Residential  
All Drain & Plumbing Needs

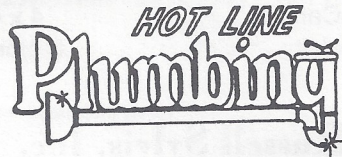

(818) 315-8601  
State Contractors Lic. #682431

**JED**

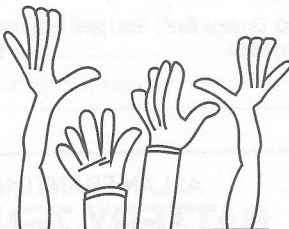

**VOLUNTEERS  
NEEDED**

*Open Election Will Be Held At The  
October Meeting - Contact Dick Smith*

**SIGNS™  
2000**

Commercial Signs, Banners, Flags & Graphics Since 1989

*Michelle Lindberg*  
Sales Manager

7245 Topanga Canyon Blvd., Canoga Park, CA 91303

818/704-7700 Fax 818/704-0292

## PAST PRESIDENTS

JIM ROWE.....	1971
DOUG PETERSON.....	1972
DON DURKEE.....	1974
ED WARNOCK.....	1975
JOHN BUSK.....	1976
CHIP WERSTEIN.....	1977
STAN MARSRAJE.....	1978
BOB DRAKE.....	1979
BILL CULP.....	1979
AL SPENCER.....	1980
LARRY CAPLAN.....	1981
BOB ROSE.....	1982
DON DURKEE.....	1983
PAUL KIRK.....	1984
KENT LOWRY.....	1985
DAVE SANBORN.....	1986
JOHN KEMMERER.....	1987
DUDLEY OCHSNER.....	1988
JERRY JENSEN.....	1989
JERRY JENSEN.....	1990
JOE DiFATTA.....	1991
CHUCK SHUBB.....	1992
CHUCK SHUBB.....	1993
GEORGE RICHARDS.....	1994
JERRY LITTNER.....	1995

**Meetings are held on the first Sunday of every month at 7:00 p.m.**

**The Valley**  **'s**

10532 GERALD AVE., GRANADA HILLS, CA 91325

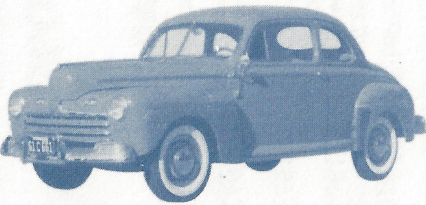
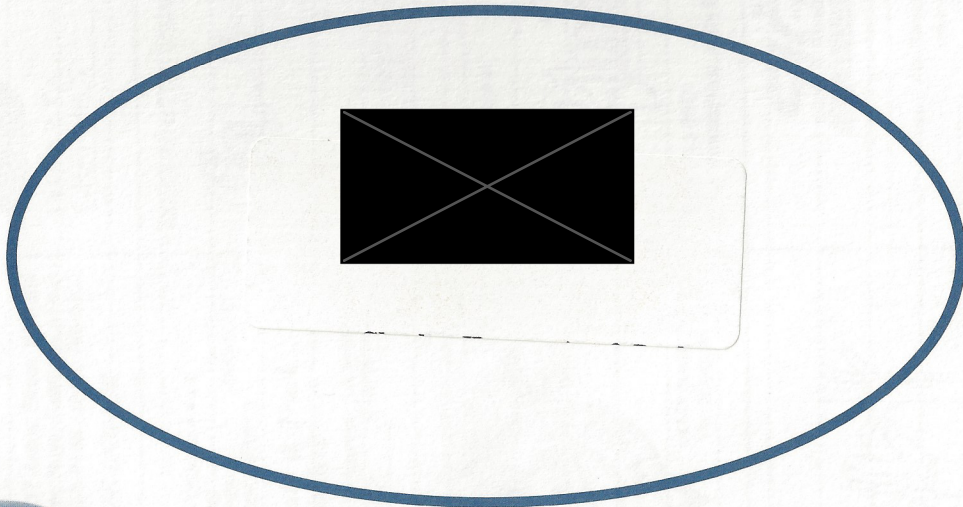

**1946 Ford Coupe**