

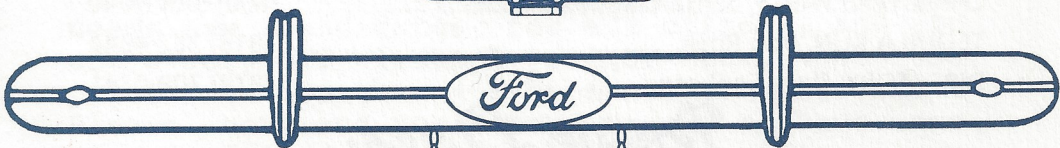

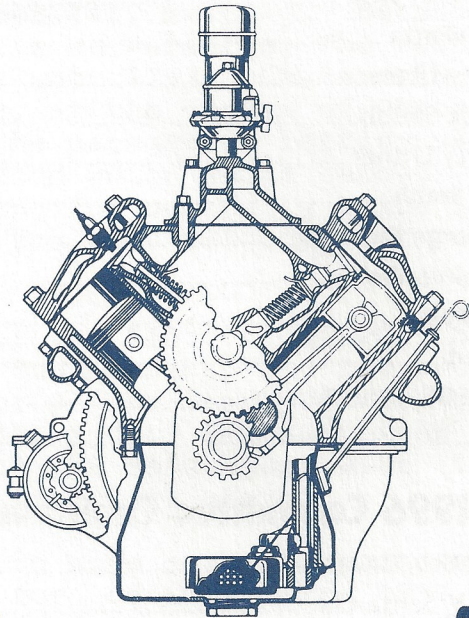

OCTOBER

## Our 25th Year



San Fernando  
Valley 's  
CHAPTER 40



# Drive Lines

# The Valley 's

---

## 1996 OFFICERS

PRESIDENT, Dick Smith.....	(818) 368-5890
VICE PRESIDENT, John Wolf.....	(818) 789-6201
SECRETARY, Joe DiFatta.....	(818) 700-1939
TREASURER, Lesley Littner.....	(818) 597-9016
PROGRAMS, Chuck Shubb.....	(818) 882-2927
ACCESSORIES, Jerry Littner.....	(818) 597-9016
HISTORIAN, Patti Smith.....	(818) 368-5890
MEMBERSHIP, George Richards.....	(818) 992-4537
FELLOWSHIP, Virginia Wolf.....	(818) 789-6201
RAFFLES, Chuck Mair.....	(818) 785-9413
EDITOR, Don Stout.....	(818) 998-7054
TECHNICAL ADVISOR, Don Durkee.....	(805) 495-5298
TOUR MASTER.....	EVERYONE

## 1996 Committee Chairmen

ANNUAL PEPPERMILL, Dave Sanborn.....	(818) 709-0741
CHRISTMAS PARTY, Santa Claus.....	(800) SANTA 40
TEQUILA RUN, Bob Rose.....	(818) 362-4842
DIRECTORY, Dave Sanborn.....	(818) 709-0741

## *Drive Lines*

Published By

SAN FERNANDO VALLEY CHAPTER 40  
of the EARLY FORD V8 CLUB OF AMERICA

P.O. Box 96  
Reseda, CA 91335

# PRESIDENT'S MESSAGE

October 1996

## *THE VALLEY V8'S 25TH ANNIVERSARY YEAR*

Hello Fellow Club Members:

We had another great turn out for our September meeting. We are going to meet at a new location for our October 1st. meeting, because of the excessive noise at Weiler's. The restaurant is BAKERS SQUARE at 17921 Chatsworth Street in Granada Hills, at the corner of Chatsworth St & Zelzah Ave. the manager is letting us have the entire back room which seats about 100 people, and the parking for our early FORDS looks very good, I hope you will all come out and give it a try.

The winner for the \$40.00 JACKPOT name badge drawing was Bob Monnick, and the two ladies to win the door prizes were Jackie Monnick and Rose Gott, the trophy for September early Ford driven went to Cal Beauregard with 1939 Ford, congratulations to all of you.

Ok, now down to some serious business at hand, nominations for officers for 1997, the club needs new candidates for all offices, and to use a very old cliché "you get back, what you put in" or something like that, is very true. Please come and nominate yourself or have one of your friends nominate you for an office, you won't be sorry. Being president this year I've had more fun, coming to meetings, going on tours and being with friends, and that's what it's all about. And for that I would like to thank each and everyone of you. So come on, let's make '97 a great year. I'll be looking forward to seeing all of you October 1st at BAKERS SQUARE.

Yours Truly,

Dick Smith

October 1st  
NEW MEETING PLACE  
*Bakers Square Restaurant*

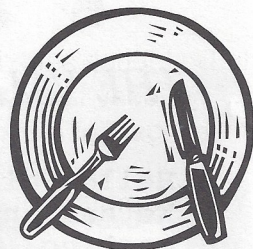

17921 Chatsworth Street  
Granada Hills

(at the corner of Chatsworth St. and Zelzah Ave.)

6:30 PM PARKING LOT TIRE KICKING & VISITING  
& Dinner if wanted, the food is good.  
7:30 PM MEETING STARTS

Two ladies in attendance will receive a door prize.

The Trophy for the September 3rd Meeting will be given to a early FORD 1932-53 product in the parking lot, to be chosen by George Richards, Jerry Jensen, and Chuck Shubb they are the judges, so bring your cars.

The name badge drawing (JACKPOT \$20.00), to be given to a club member in attendance that is wearing their badge.

Early FORD's driven to any Meeting, Tour, or Events will receive points, at the NOVEMBER MEETING, the member who has the most points will WIN a \$100.00, and 2nd place will WIN \$50.00.

Nominations for the 1997 OFFICERS, we need your voice, at our NEW quiet meeting place.

Many people feel that the development of the internal combustion engine, the drive train, and pneumatic tires were the catalysts for the automobile becoming a practical method of transportation. From there, companies in Europe such as Peugeot, Renault, Fiat, and Daimler-Benz and pioneers in the US such as Henry Ford, Charles and Frank Duryea, and Ransom E. Olds helped lay the foundations for an industry that is one of the biggest in the world today.

CELEBRATING THE 100TH ANNIVERSARY  
OF THE AMERICAN AUTOMOBILE 1896-1996

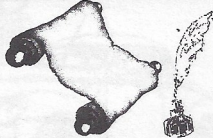

# Secretary's Report

by Joe DiFatta

L. B. J. once said "My fellow Americans, today I speak to you with a heavy heart ..." so today I say "My Fellow Ford Friends ..." Lots of items come across at our meetings, but do you realize the man or woman hours spent to provide good meetings, good programs, good tours, good raffles, good bulletins, etc...etc...? **Your compliments go a long way!!** Enough for now.

We had a big turn out of members, 22 cars and 3 guests plus a couple of new members. PRESIDENT DICK announced that we will have an open election of officers for the October meeting.

September Car Trophy went to CAL BEAUREGARD for the best looking Ford in the parking lot. The Ladies Raffle was won by JACKIE MONNICK and GERRY BLACKWELL. DICK received a letter from the National Secretary stating that as of January 1st all members must be a member of the National Group, which also includes receiving the bi-monthly "outstanding" Ford Times Magazine.

CHUCK MAIR collected \$150 tonight for the raffle. I even saw DAVE SANBORN win a prize ... with ticket no. 1936!!

CAL BEAUREGARD was our program and spoke about his early days with the Ford Co. and brought family photos for us to see.  
Always Great Stories!!

## Serious Time

- We need a quieter place for the club to meet
- Also, need a new printer. After 10 years of printing the Drivelines, it's time to find someone else.

*New Valley V8*  
*Mailing Address*

**P.O. Box 4033**  
**Chatsworth, CA 91313**

### Ford Fact

In the 1932 model year, the four cylinder engine was used in 96.5% of all light commercial units and 98.5% of all heavy trucks. The "new" V-8 engine became more prominent in the commercial line in 1933.

# Editor Says

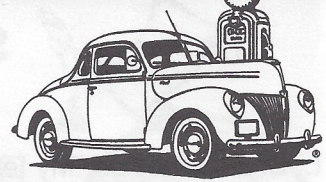

Cheryle and I were off to Tahoe this month. Up on 395, not quite as hot as it was for the V8ers last month. Our Roofing Conference was at the same hotel, the Horizon at Tahoe's "Cool September Days" – 3 day car show. What beautiful cars and the mileage driven to the show was on everyone's windshield: over 300 cars and most were over 100 miles, and I saw some at 460, 502, and 503 miles. We came back the 15 then cut over to 101 at S.L.O. then down to Mandalay Beach just in time to wash my sport sedan up for the Channel Island Show on Sunday morning. There were about 200 cars on the grass at the Marina on a beautiful day, Great show. As you can see our week went well, a "Contractor of the Year" award from the California Roofing Contractor Association and a 2nd Place Trophy for the car.

We are off to the Pepper Mill on Sunday, Dave Sanborn expects about 90 people, hop to have some pictures for printing. don't forget the election this meeting at Bakers Square.

Ed

*Dear Ed,*

*My Ford is out for repairs...if I borrow a club member's Ford, will I still get a point??*

*Lonesome Ford*

Dear Lonesome,

Good Luck!! To borrow another man's car is like borrowing his wife... wait till next year's quiz.



**When did Gerry Blackwell  
or her "double",  
take up riding  
a Cushman Bike??**

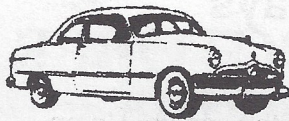

The following cars and drivers have points towards the November JACKPOT

****	Virginia & John Wolf	15 points
***	Patti & Dick Smith	14 points
**	Rose & David Gott	13 points
*	Donna & Lloyd Paschal	12 points
*	Gerry & Blacky Blackwel	12 points
*	Lin & John Kemmerer	12 points
*	Dick Stone	11 points
*	Al Rohrer	10 points
	Lesley & Jerry Littner	9 points
	Shirley & George Richards	8 points
	Carole & Jerry Jensen	8 points
	Richard Valleroy	8 points
	July & Chuck Shubb	7 points
	Dottie & Ken Schmelzel	7 points
	Chuck Mair	7 points
	Mary & Don Durkee	6 points
	Sue & Steve Boskovich	5 points
	Jackie & Bob Monnick	4 points
	Wayne Burns	4 points
	Leslie Mac Willie	3 points
	Bob Reed	3 points
	Vicki & Dennis Keene	3 points
	Nancy & Cal Beauregard	2 points
	Ken Sapper	2 points
	Carlos Wilhelm	2 points
	Allen Franklin	2 points
	Dave Sandborn	2 points
	Ann & Larry Caplan	2 points
	Bill King	1 point
	Cheryle & Don Stout	1 point
	Bob Rose	1 point
	Richard Chutuk	1 point
	Barbara & Howard Simpson	1 point
	Jan & Ed Hardin	1 point
	Harold Johansen	1 point
	Joe Simon	1 point
	Joe Areana	1 point
	Kent Lowry	1 point
	Ed Warnock	1 point



# OCTOBER V8 Birthdays



Oct. 1	Art Surtees
Oct. 3	Dave Sanborn
Oct. 12	Cheryle Stout
Oct. 15	Richard Mottern
Oct. 20	Isabel DiFatta
Oct. 20	Clara Jo Ostergran
Oct. 23	Bob Rose
Oct. 24	Leslie Littner
Oct. 24	Jan Hardin
Oct. 29	Cal Beauregard

## EARLY V8 FORDS DRIVEN TO THE MEETING

1940 FORD Tudor Larry Caplan  
1932 FORD Cpe. Ed Warnock  
1948 MERC Brent Allred  
1950 MERC. Ken & Dotti Schmelzel  
1940 FORD 4 door Rose & Dave Gott  
1940 FORD Cpe. Dick Stone  
1939 FORD Cal & Nancy Beauregard  
1951 MERC. Allan Franklin  
1940 FORD Cpe. Gerry & Blacky Blackwell  
1948 Ford Cpe. Joe Di Fatta  
1940 FORD Cpe. John & Virginia Wolf  
1940 FORD Cpe. Patti & Dick Smith  
1950 MERC. 4 door Joe Areana  
1939 FORD Conv. Shirley & George Richards  
1951 FORD Kent Lowry  
1953 FORD Cpe. Donna & LLOYD Paschal  
1948 FORD Cpe. Steve Boskovich  
1941 FORD Conv. July & Chuck Shubb

The other classic cars driven were,  
Don Stout 1956 Chevy, Lee Chase 1948 Studie



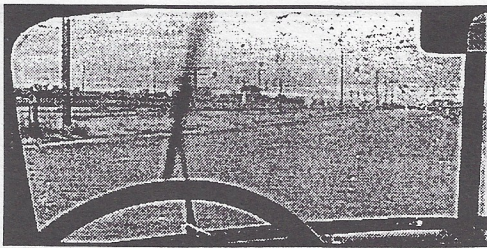

## “Looking Ahead”

October 1st 7:30 p.m.

New meeting place at Bakers Square Restaurant  
17921 Chatsworth Street, come early for tire kicking and dinner.

October 6th

All Ford Picnic  
La Palma Park

October 12th

Ventura V8s Beach Party

October 13th

Pomona Swapmeet

October 20th 10:30 a.m.

Tour to Art Astor's  
Meet at Woodley Park, call Dick Smith for details

October 20th

so. Cal Annual to Laughlin

November 1st

Sequoia Tour  
Contact Gerry Blackwell

November 3rd

Baldy View Car Show

November 5th - 7:30 p.m.

Meeting at Bakers Square Restaurant  
17921 Chatsworth Street, come early  
for tire kicking and dinner.

September '97 Europe Tour

24 cars - 50 people only

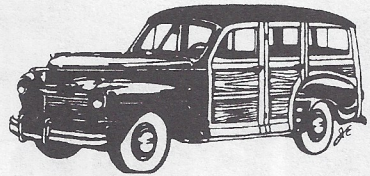

**A Warm Smile is the  
Universal Language  
of Kindness**

*- Wm. Arthur Ward*

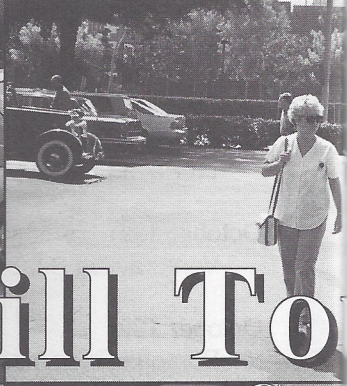
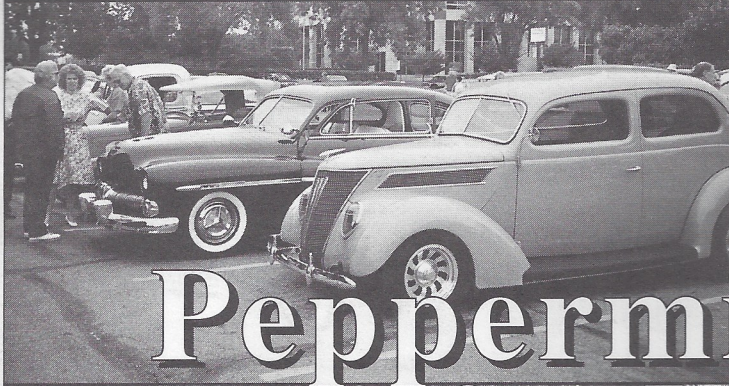

# Peppermill To Great Turnout • Gre Thanks Da

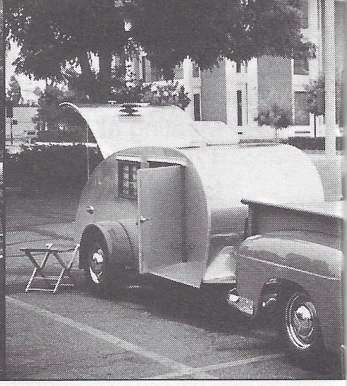
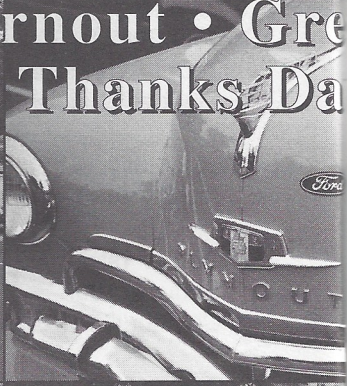



# Fun & Breakfast

at Cars • Great Raffles  
we Sanborn!

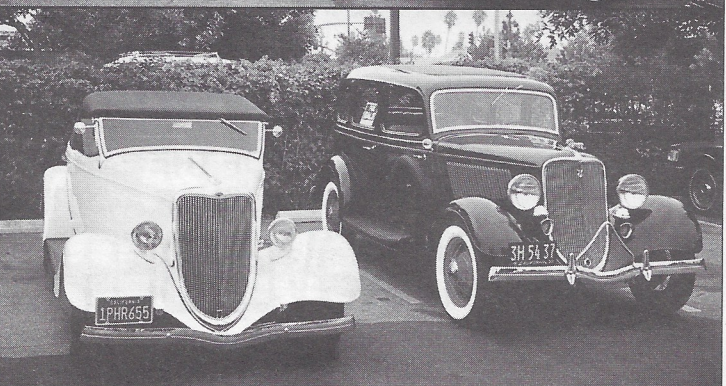
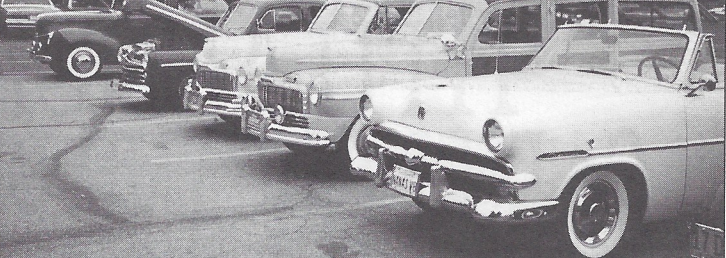

# Local Cruz Nights

SATURDAY 5p.m.

Carney's Restaurant - 12601 Ventura Blvd., Santa Clarita

SUNDAY 4 - 8p.m.

Weilers' N.Y. Deli - 16150 Nordhoff Street, North Hills

WEDNESDAY evenings

Abe's Deli - 19626 Nordhoff, Northridge

Star's Drive-in - 20445 Sherman Way, Canoga Park

THURSDAY evenings

Teddy's Drive-in (Smith's Favorite) - West Los Angeles

FRIDAY evening

Bob's Big Boy - 4211 Riverside Drive, Toluca Lake

Cruiser's Car Wash - Tampa at Plummer, Northridge

SATURDAY mornings

Holiday Inn - Thousand Oaks

---

# 11TH ANNUAL CAR SHOW AND PICNIC

PRESENTED BY

REGISTRATION  
\$10 DOLLARS  
PER CAR

**BALDY VIEW**

CHAPTER OF THE EARLY  
FORD V-8 CLUB OF AMERICA

AWARDS  
DASH PLAQUES  
RAFFLE  
DOOR PRIZES

# SUNDAY NOVEMBER 3RD 1996

FOR ADDITIONAL INFO. CALL  
(909)985-4381 OR (909) 982-5398

TWENTY  
SEVENTH  
ANNUAL

# ALL *Ford* PICNIC

La Palma Park  
Anaheim, Calif.

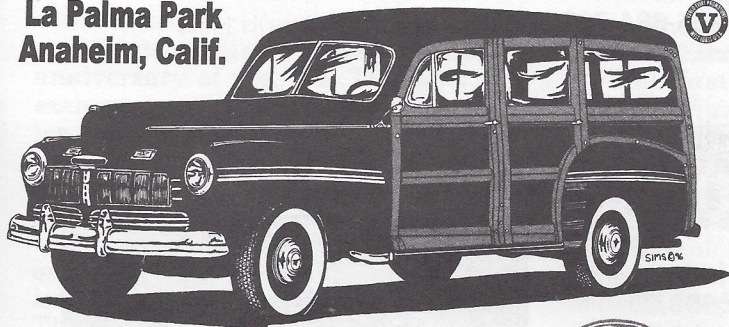

No Alcohol  
For further information please call:  
Jerry (714) 494-1858  
Sam (714) 523-8087



All years  
Ford's  
Lincoln's  
Mercury's

GOODY BAGS  
(First 300 cars)

COFFEE & DONUTS  
IN AM

RAFFLE  
(Inc. one weeks use of any  
Ford product)

TROPHIES

DOOR PRIZES

DASH PLAQUES  
(First 300 cars)

50/50 RAFFLE  
FUND  
FOOD  
FORDS  
FRIENDS

How could we better wish our members.....  
"Happy Halloween",  
then DRAKE'S ad in HMN.

*Pumpkins & Fords*

Editor

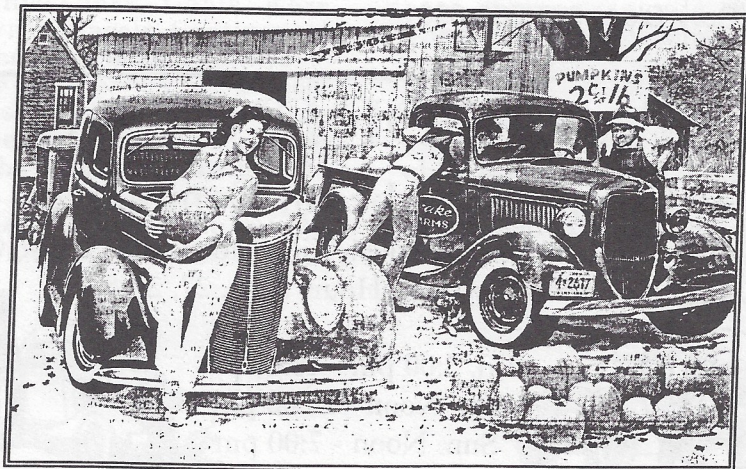

Pumpkins are available anywhere--QUALITY comes from DRAKE

## Cars & Parts For Sale

'36 Cabriolet, Rumble Seat

Body off restoration, washington blue, Ed Warnock L.B.  
engine, body back on frame, grill crowned, radiator rebuilt,  
new firestone wide whites, all pieces. Needs Finishing.  
\$17,500 obo

Don Ashworth 805 684-7125

'33 Four door

body off restorations, maroon & black, hydraulic brakes, L.B.  
interior as seen at PepperMill Brunch. \$18,000

Richard Gillett 818 966-5283

'64 Chevy 3/4 ton

new motor \$1,900.00

Don Durkee 805 495-5298

'57 Ranchero

292 V8, 2-tone clean

William 818 914-7616

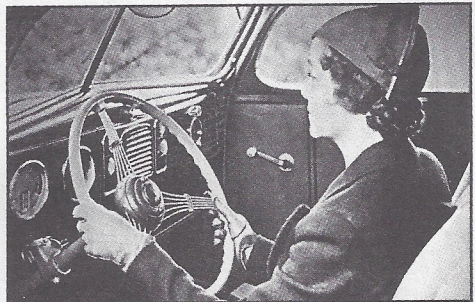

1933-34 NOS pair of running boards \$1,400.00

Ed Warnock 818 346-7882

## Cars & Parts Wanted

1953 - 56 front fenders for F-100 pick-up in good condition.

Gary Glass 805 383-6901

## TASTE OF ENCINO

### Encino Chamber of Commerce

Food, Wine, Entertainment Festival, Kids Rides, and Classic Car Show  
Extended Days and Hours Sept. 27, 28 & 29



Fri. 5:00 pm - 10:00 pm

Sat. Noon - 10:00 pm

Sun. Noon - 7:00 pm



# SOMEWHERE WEST OF LARAMIE

BY TIM HOWLEY

I just realized it is the 50th anniversary of the '46s. That was an exciting year. War was over. America was brimming with optimism. It was evident at showrooms which, in late 1945, were jammed with buyers swooning over little-changed cars.

Ford was first to produce new cars on July 3, 1945. By the end of 1945, less than 35,000 '46 Fords were built. The first '46 Ford was delivered to President Truman by Henry Ford II. The '46 Ford and Mercury Sportsman woody convertibles came out, and the first one went to actress Ella Raines. The Lincoln Continental bowed in mid 1946, and Henry Ford II paced the Indy 500 with one of the first '46 Lincoln Continental convertibles built.

Many Hollywood stars took delivery of '46 Ford products, including "cheapskate" actor Jack Benny, who had a Lincoln Continental cabriolet. Bob Hope and Greer Garson had Lincoln Continental coupes. Ronald Reagan and Clark Gable were pictured with Lincoln Continental cabriolets they may not have owned.

The '46 Ford, Mercury and Lincoln had extensive facelifts including attractive new instrument panels and interiors. The Ford was introduced to the public on Oct. 26, 1945. The Mercury made its debut on Dec. 14

and the Lincoln on Jan. 19, 1946

The first two postwar cars tested for *Mechanix Illustrated* by Tom McCahill were a '46 Ford and '46 Buick for the February 1946 issue. He established a penchant for Ford products, and a disdain for Buicks.

Chevrolet started slow, producing few cars in 1945. From 1946 on, it outsold Ford. The '46 Chevys were less changed from 1942 than Fords, and probably didn't have to be changed at all to hold the number one position.

While Pontiac retained triple speed lines, the '46 grille was cleaner, giving a new look, but there wasn't much change. You couldn't get Hydra-Matic.

The '46 Olds had about the biggest changes. Replaced by a modern unit with four arches, was the novel 1942 B-44 grille. The series were changed. There were many model realignments. Mechanically, it was the same old roast-beef-and-mashed-potatoes '42.

Buick dropped its 118-in. wheelbase. There was only the 121-in. wheelbase Special, Super and Roadmaster. Specials were reduced to a sedan and sedanet. One wagon was offered - a Super. The newest feature was a bombsight hood ornament, which said a lot about the industry.

It took a Sam Spade-trained eye to differentiate a '46 Cadillac from a '42.

*Continued*

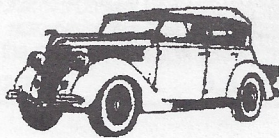
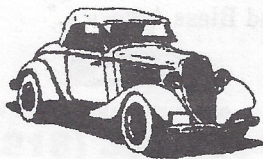

Continued from page 13



Grilles and side trim were unchanged. The number of series and models was reduced. While others ballyhooed their facelifted '46 models, the arrival of the '46 Cadillacs came as quietly as a night in Digger O'Dell's basement.

Chrysler was the "status quo" leader, and even its '49 models resisted major styling change. The '46 Plymouth had a new grille, side trim, hood ornament, and rear fenders.

For Dodge, the biggest difference from '42 was a waffle-iron grille. The most exciting change was placing the starter button on the dash, instead of retaining a foot-pedal starter button.

DeSoto's biggest changes for 1946 were the elimination of "Airfoil" hidden headlamps and a reduction of body styles. New was the Suburban.

The '46 Chrysler had ornate new grillework, and the 1942 mottled plastic interior trim gave way to solid plastics in various colors. The new car of the year was the '46 Chrysler Town & Country. The sedan had an entirely different wooden body than 1941-'42. A stunning T & C convertible was added. Brougham, convertible coupe and hardtop versions of the Town & Country were planned but never produced, although a few prototypes of some of these models were built.

Packard continued its '42 Clipper bodies with new grilles, and 14, instead of six, series. The '46 and '47 Packards were identical. Packard was in healthy financial condition. Maybe it should have continued selling 1946-'47 Packards for another decade.

Hudsons remained 1942 models

with 1946 grilles. All sixes and eights came on the 121-in. wheelbase. There were three transmissions - overdrive, Vacuumotive (that automatically engaged and disengaged the clutch), and DriveMaster, which eliminated the clutch and gear-shifting functions:

The '46 Nashes were '42s with more grille bars. Nash outsold Chevrolet in 1945, and produced 94,000 cars in 1946. Nash, Hudson and Packard all proved that "much ado about nothing" was enough to sell cars in 1946.

Studebaker began 1946 with facelifted '42s. Then, in the spring of 1946, it stunned the industry by introducing new models. These were '47 models, not '46s. Styling was done by the firm of Raymond Loewy and Associates. Loewy had subcontracted post-war Studebaker design to Virgil Exner. He worked up the car in his basement studio at home. Wartime government restrictions had no effect on this effort, which was up to the clay stage and ready for production just about the time Japan surrendered.

If you don't remember World War II, you'll ask, "How could anybody in 1946 get excited over those '42 automobiles with '46 "dental plates?" Think about it - if you were a GI arriving home from the war, any '46 car looked as good as Betty Grable.

Things were different than now. We were perfectly content with chicken on Sunday, black-and-white movies, no television, radio, and quiet evenings at home with Kate Smith singing "When the Moon Comes Over the Mountain" and "God Bless America."

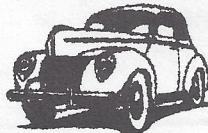



# SUPPORT OUR ADVERTISERS!

## Chatsworth Auto Upholstery

Classics • Hot Rods • Foreign & Domestic

JIM ORTUNO  
(818) 882-5161

21300 DEVONSHIRE ST.  
CHATSWORTH, CA 91311

FLIP SMITH



7735 SEPULVEDA BOULEVARD  
VAN NUYS, CALIFORNIA 91405

Bus: (818) 786-8686

Fax: (818) 785-2982

## DON'S Auto Parts

MACHINE SHOP and BALANCING

Monday thru Friday 8 a.m. to 7 p.m.  
Saturday 9 to 6 - Sunday 10 to 4

10241 Woodley (At Devonshire)

Domestic &  
Foreign

Parts & Supplies



(818)

**894-6441**

Sepulveda, CA 91343

RAFFLE PRIZE DONOR

LESLEY A. LITTNER  
(818) 597-9016 / FAX:597-9145

## BOOKKEEPING & BUSINESS SERVICES

5051 BLACKPOOL AVE.  
AGOURA, CA. 91301



Older Cars  
A Specialty

4 x 4's and  
Motorhomes

Russell Sylvis, Inc.  
Transmissions  
Repaired • Rebuilt

(805) 527-4387

4657 Barnard St.  
Simi Valley, CA

## R.C. Smith's Roofing Solutions

Roofing & Waterproofing • Complete Maintenance Service

8707-D Lindley Ave., Ste. 199, Northridge, CA 91325  
Lic. #356650 (818) 718-2313

Auto • Homeowners

- ANTIQUE CARS -

## ED HARDIN INSURANCE

Business • Life • Health • Aircraft



Call us for your Insurance needs!

**(818) 363-7864**

## ALLAN FRANKLIN'S BATTERY TENDER

**\$59.99**

club members  
\$54.99

Charges battery up and turns itself off  
automatically when it fully charged.

Takes the guess work out of battery maintenance!

(818) 842-2230

6, 8, or 12 Volt Models

# SUPPORT OUR ADVERTISERS!

## L.T. "LEE" SAWYER, INC.

Jobber

Shell Oil and Chemical Products

14117 Aetna Street, Box 369  
Van Nuys, California 91408

TOM SAWYER (818) 786-8180 / (818) 785-0902

**RAFFLE PRIZE DONOR**

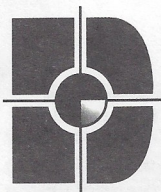

**DiFATTA  
GRAPHICS**  
Incorporated

**Joe DiFatta**  
Chief Executive Officer

27642 Avenue Hopkins  
Valencia, California 91355

Phone: 805 295-8788  
800 990-1939

Fax: 805 295-5069  
Modem: 805 295-5119

CHEVY AND FORD TRUCKS • 4 x 4  
55-56-57 CHEVY CARS 67-87 CAMARO 64-87 CHEVELLE  
NEW AND USED PARTS

**American Auto & Truck  
Dismantlers**

12172 Truman St. • San Fernando, CA 91340  
(at Hubbard) **ROGER** (818) 365-3908

RESIDENTIAL • COMMERCIAL • INVESTMENT



**Spencer Realty**

3948 Goodland Ave.  
Studio City, CA 91604  
Office: 818-761-1734  
Fax: 818-761-7952



**AL SPENCER**

QUALITY PROFESSIONAL SERVICE



John Mangiapane  
(818) 994-5077

14743 Keswick Street  
Van Nuys, CA 91405

Low prices  
Repiping Specialist

Commercial & Residential  
All Drain & Plumbing Needs

**HOT LINE  
Plumbing**

(818) 315-8601  
State Contractors Lic. #682431

**JED**

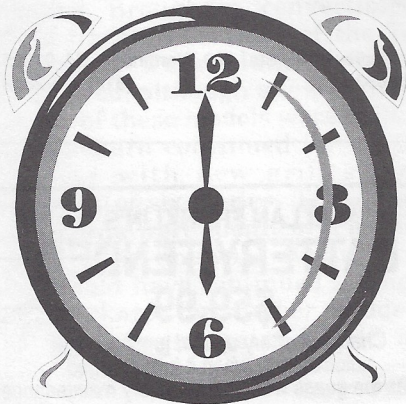

**October 27th  
Turn Your Clock Back!**

**SIGNS™  
2000**

Commercial Signs, Banners, Flags & Graphics Since 1989

**Michelle Lindberg**  
Sales Manager

7245 Topanga Canyon Blvd., Canoga Park, CA 91303

818/704-7700 Fax 818/704-0292

## PAST PRESIDENTS

JIM ROWE.....	1971
DOUG PETERSON.....	1972
DON DURKEE.....	1974
ED WARNOCK.....	1975
JOHN BUSK.....	1976
CHIP WERSTEIN.....	1977
STAN MARSRAJE.....	1978
BOB DRAKE.....	1979
BILL CULP.....	1979
AL SPENCER.....	1980
LARRY CAPLAN.....	1981
BOB ROSE.....	1982
DON DURKEE.....	1983
PAUL KIRK.....	1984
KENT LOWRY.....	1985
DAVE SANBORN.....	1986
JOHN KEMMERER.....	1987
DUDLEY OCHSNER.....	1988
JERRY JENSEN.....	1989
JERRY JENSEN.....	1990
JOE DIFATTA.....	1991
CHUCK SHUBB.....	1992
CHUCK SHUBB.....	1993
GEORGE RICHARDS.....	1994
JERRY LITTNER.....	1995

**Meetings are held on the first Sunday of every month at 7:00 p.m.**

The Valley s

10532 GERALD AVE., GRANADA HILLS, CA 91325

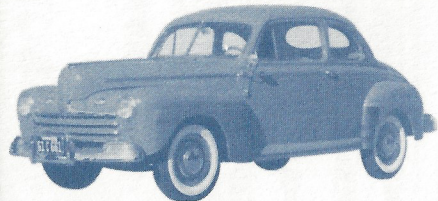
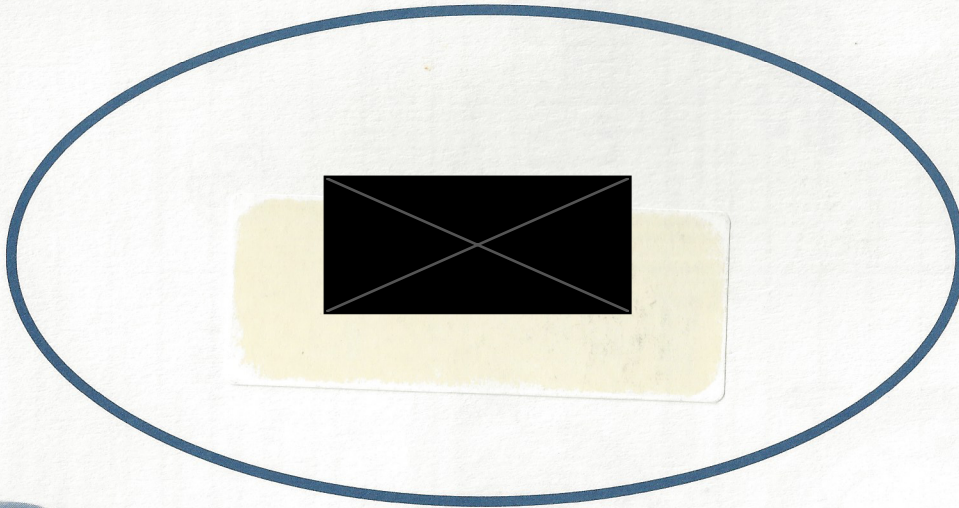

**1946 Ford Coupe**