

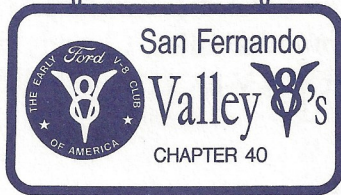

FEB 2000

2000

Our 30th Year

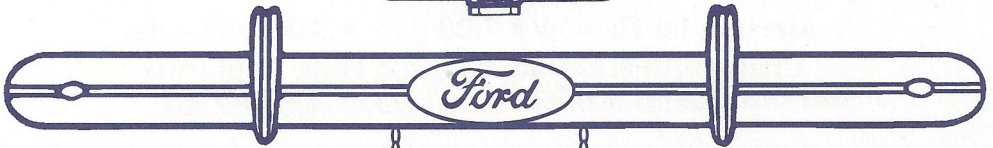
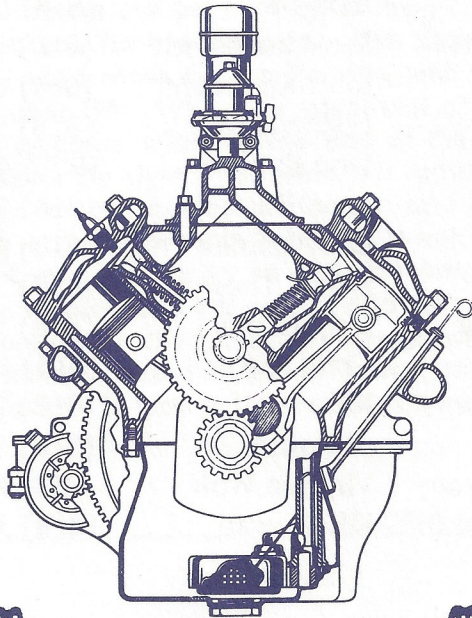

Drive Lines

The Valley

2000 OFFICERS

.....

<i>President</i>	Don Stout	(818) 998-7054
<i>Vice President</i>	Steve Boskovich	(818) 341-6876
<i>Secretary</i>	John Kemmerer	(818) 843-2138
<i>Treasurer</i>	Lesley Littner	(818) 597-9016
<i>Tours</i>	Don Durkee	(805) 495-5298
<i>Programs</i>	Joe DiFatta	(818) 700-1939
<i>Editor</i>	Larry Caplan	(818) 366-9178
<i>Publisher</i>	Darryl Thomas	(818) 363-6914
<i>Membership</i>	Jerry Littner	(818) 597-9016
<i>Raffles</i>	Craig Lapair	(818) 893-1640
<i>Tech Advisor</i>	John Wolf	(818) 789-6201
<i>Accessories</i>	Al Rohrer	(818) 345-3721
<i>Social Secretary</i>	Virginia Wolf	(818) 789-6201
<i>Ladies Gifts</i>	Edy Cowan	(818) 366-5530

Meeting 1st Tuesday • 7:00 p.m. • Baker's Square
Chatsworth & Zelzah, Granada Hills, California

The *DRIVE LINES* is published by:
The San Fernando Valley, Chapter 40
of the EARLY FORD V-8 CLUB of AMERICA

Mailing Address:

VALLEY V-8's
10944 Oklahoma Ave.
Chatsworth, CA 91311



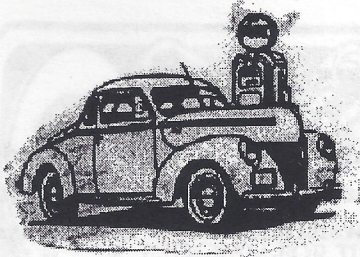

BETWEEN DRIVES

A lot happened before our first meeting of the year. Cheryle and I became grandparents for the first time. Miss Blaise Lane Stout, 8 pounds and 7oz, was born to our son Dondee, with a lot of help from Dessie, on December 19th, 1999. My retirement after 30 years in the roofing business became effective the end of the year and I now have a much slower life style. We filled our remaining positions of editor, publisher and tour master and are off and running on a tag along tour to the Reagan library in February. I enjoyed the program on Angel's Flight and we will try to balance programs of general interest with pure V8 programs this year. I also look forward to driving my '40 much more than last year, with a little good luck and a lot of help from my friends. I also hope to spend more time on the computer learning how to type and write this column.

PRESIDENT DON

JANUARY AND FEBRUARY BIRTHDAYS

1/3	Jean Welch	2/4	Marsha Di Fatta
1/3	Barbara Wright	2/4	Beth Mac Arthur
1/10	Barbara Williams	2/4	Sandra Otte
1/10	Leo Nitz	2/11	Don Durkee
1/19	Jack Miles	2/17	Diane Baily
1/25	John Wolf	2/19	Leland Wright
1/25	Lu Anne Rohrer	2/25	Ralph Otte
1/27	Don Zabel	2/25	Joe Di Fatta
1/28	Jerry Littner	2/27	Lin Kemmerer

THE EDITOR'S PAGE

I guess what goes around eventually comes around. I had this position back in 1979 using a typewriter, Xerox copier and a scissors to paste up the monthly newsletters. Now I compose the pages using a Windows based personal computer, collect the columns using e-mail via the internet, and paste up the newsletter using a scissors and a Canon copier. So as you can see, the more things change, the more things stay the same.

My goal for the remainder of the year is to publish monthly newsletters which will hold your attention as you read from cover to cover. This issue contains sixteen pages thanks to some great material submitted by our members. I want to continue with this size, but only if we have the quality stories, photos and other materials to complement our regular monthly columns. Please help me make this year the best ever by volunteering to submit a personal story about your life with Early V8 Fords or put together a car related story that will be of interest to our readers. You may submit your story handwritten or in any form you wish and I will prepare it for the newsletter. Please let me know if you have any "clip art" containing Ford V8s and related graphics.

Several late breaking new items. As of this writing we have just filled our last open office with Don Durkee accepting the position of Tour Leader. He also holds this position for the Ventura V8s and we will have several joint tours with that group during the year. Virginia Wolf, our Social Secretary, sent a Christmas basket of food and goodies to Don at Don's Auto Parts for his contributions to our monthly raffles. We have just learned of the passing of Roy Jones, the well known automotive artist. He not only designed our Drivelines cover but has done numerous art pieces for Bob Drake's catalogs and calendars. If you like 1940 Fords, and who doesn't, you must get one of Bob's calendars for 2000. This calendar has twelve 1940 Ford renderings by Roy Jones which are awesome. See you on February 1st.

LARRY

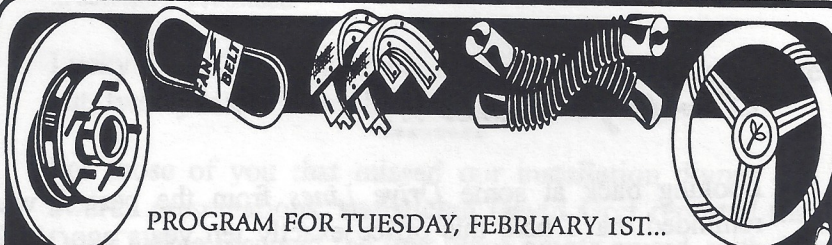

PROGRAM FOR TUESDAY, FEBRUARY 1ST..

"EVEN CADILLACS HAD FLATHEAD V-8 MOTORS..."



Our speaker on February 1st will be Ed Cholakian, owner-operator of "All Cadillacs of the Forties," since 1977. Ed has over 150 Cadillacs, buys and sells parts in Sylmar. Every fall, he goes back to Hershey, Pennsylvania for the swap meet . . . and of course, brings home lots of goodies. We have been invited to visit his warehouse.

Ed is very, very active in his community. He even owns a Limousine service, using his Cadillacs for limo service.

He and wife, Diane own Uniglobe Travel and enjoy traveling (who doesn't!). Ed recently was elected to serve on the L.A.P.D. Historical Society. The L.A.P.D. is building a museum in the L.A. area.

Ed will talk about his love for cars and experience in buying, selling and restoring automobiles.

BRING A GUEST.

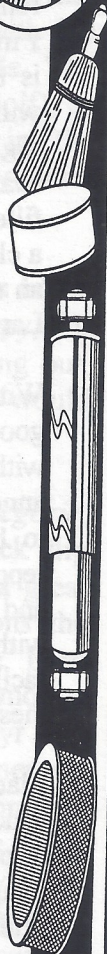
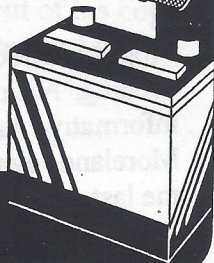
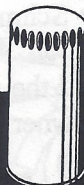

Secretary's Corner ...

Looking back at some *Drive Lines* from the past, I was reminded that I held this office exactly ten years ago. And, I'm not the only one. After a two-decade hiatus, Larry Caplan is back at the typewriter (pc). This guy and his continued willingness to step up and take responsibility, when our regional group needs something done, puts the rest of us to shame. He's done it many times, whether we needed an office filled, or a last minute program. Each time he volunteers, he's a class act. If the past is truly prologue to the present, look for an excellent newsletter this year. Now do your part and send Larry your articles and information.

With plenty of good-looking Fords in the parking lot and a good crowd on hand, the new year got off to a great start, with President Don Stout in the driver's seat. Treasurer Lesley announced dues are due, so send her your 25 bucks. Or give it to her, no later than our meeting on the 1st. Lesley also reported that the club donated \$250 to Children of the Night and a like amount to the House of Ruth. There will be a tile, with the Valley V-8's name on it, at the House of Ruth's new facility. If you are interested in learning more about either of these organizations, see Patti Smith at our next meeting.

Blacky Blackwell, the new president of the Ventura V-8's announced that their regional group has been invited to display their cars and attend a VIP reception at the Ronald Reagan Presidential Library, on February 6th. Blacky extended the invitation to our club.

Program Director, Joe DiFatta, introduced our speaker for the evening, Nancy Schmidt. Nancy gave a very interesting and informative talk on Angel's Flight. Her grandfather, Lester Moreland, owned the railroad from 1952, until 1962 and was the last private owner of Angel's Flight.

continued ...

... secretary continued:

Lucky Rose Gott took home, not only the ladies door prize but, twenty bucks from the name badge drawing.

For those of you that missed our installation dinner and awards presentations, statistician David Gott reported that Don Durkee received the first place points award, with Joe DiFatta a close second. On the subject of awards, The Valley V-8's' answer to Bo and Luke (Smith and Wolf), as past "Best of Show" winners, are competing in the Glendale Bob's "Car of the Year Award" competition, with Dick's '40 coupe and John's '39 convertible.

Bob McCullagh called several weeks ago. Said he's home resting after completing chemo and radiation therapy, for cancer of his nose. Bob says his legs are also giving out, making it difficult to get to the meetings. He said he would appreciate hearing from the members.

Just received my copy of *Edsel Ford and E.T. Gregorie*, from the Society of Automobile Engineers. A quick flip through the pages tells me that this is going to be a great read. The book is based on first hand conversations the author, Henry Dominguez, had with E.T. Gregorie, Ford Motor Company's first Design Chief. "Automotive historians have listed the 1936 Zephyr, 1938 Zephyr and 1939 Continental as Gregorie's greatest achievements." The book, 330 pages, has received "thumbs up!" from our own Jerry Jensen. Jerry said he "couldn't put the thing down ... finished it in two nights." If you don't want to pony up the \$39 (don't know of anyone discounting it) to the SAE, you might be able to talk Caplan out of his copy.

See You at Baker's Square on February 1st!

... *John Kemmerer*

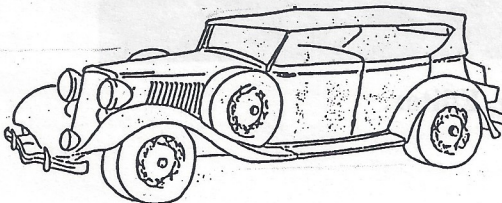

MOST ACTIVE MEMBER CONTEST FOR 2000

Once again we plan to find the most active member for the year. David Gott will be maintaining the standings and we will publish these numbers monthly. Be sure and fill out the attendance sheets each month and be sure that your name is on the list for each tour you attend. Below are the rules for earning points during the year.

ATTEND MEETING _____	1 POINT
BRING A 1932-53 FORD TO A MEETING _____	2 POINTS
ATTEND A TOUR _____	1 POINT
BRING A 1932-53 FORD ON A TOUR _____	2 POINTS
ORGANIZE A TOUR _____	5 POINTS
GIVE A PROGRAM _____	5 POINTS
PREPARE THE MONTHLY NEWSLETTER* _____	5 POINTS

FINAL STANDINGS FOR 1999

Don Durkee	44 points
Joe DiFatta	43 points
John Wolf	35 points
Dick Stones	33 points
Steve Boskovich	32 points
Al Rohrer	32 points
Dave Gott	31 points
Dick Smith	28 points
Bruce Blackwell	25 points
Jerry Jensen	24 points
Dennis Keene	23 points

* Just kidding, Editor.



CALENDAR OF UPCOMING EVENTS

February 1st _____ Valley V8s meet at Baker's Square

February 6th _____ Tour to the Ronald Reagan Library
(Contact Bruce Blackwell 661-268-0040)

February 25, 26,27 _____ San Diego Tri-Club Swap Meet at Qual
Com (Contact Len Barbieri 858-453-0683)

March 5th _____ Pomona Swap Meet

March 7th _____ Valley V8s meet at Baker's Square

March 25th _____ Tour to Edelbrock Equipment Company
(Contact Don Durkee 805-495-5298)

Swapper: "Honey, I know it's rough... but when it's done we'll haul the kids in it. "

Swapper's Wife: "To what... their retirement parties?"

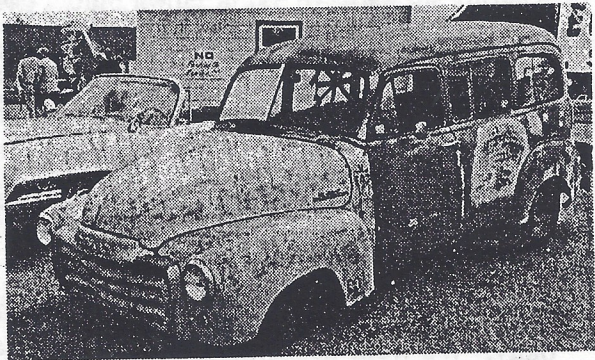

**THE CHRISTMAS EVE
WHEN I SAW MY FIRST
'41 FORD CONVERTIBLE**

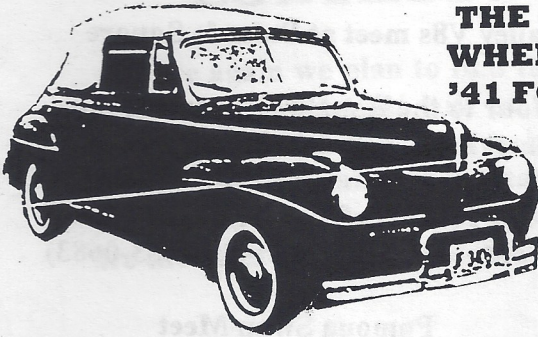

The Ford garage where I first went to work was called Modern Motors. The building was an old converted two story opera house built in the 1800s. Early in the 1900s it was converted to sell and repair Ford automobiles. The upstairs included an area for storing new cars and the autobody shop. When I got my car washing and floor sweeping jobs done I would get a chance to go help the old guy in the body shop. It was very impressive to see those smashed up cars return to new looking again.

One day while doing my cleaning jobs, the parts man asked if I would help him and one of the mechanics to move the cash register from the parts counter to another location. This cash register had not been moved for a long time since it was very heavy. The three of us finally got it moved. Later the mechanic noticed something gold shining in the corner where the cash register had been. Yep, you guessed it, it was a twenty dollar gold piece! He told me that I could have it for twenty-five dollars. I knew that it was a good buy but I didn't have twenty-five dollars on that Christmas eve day in 1955.

He did say that he would buy my lunch, and I said okay. We went down to the Green Mill Café which was a half block from the shop. The Green Mill Café was the hang out for all the young kids, those between 15 and 30

years of age. Located next door was the Sportsman's Lodge Tavern where all the old guys would hang out, those over 30 years of age. In the parking lot of the Sportsman's Lodge was a maize yellow '41 Ford Convertible. It had a black top, skirts, duals and Hollywood flipper hubcaps on the front wheels. Boy, what a dream car for a 16 year old to look at! By 1955 there were no vintage 40s convertibles in the town of Maquoketa, Iowa. Even in 1955 they used salt on the streets to melt the snow and ice. Those vintage cars were rusty and in the junkyard by then. Back at work I was telling all the mechanics about the awesome '41 Ford convertible we saw at the Sportsman's Lodge while we were at lunch. I don't think those mechanics believed me about the fantastic '41 we saw. They just thought I was a windy teenager with wild dreams about cars.

The old converted opera house also had a basement which was 100 feet long and 50 feet wide with a dirt floor. It had one 60 watt light bulb in the center and the stairway was at one end with a furnace at the other end. The stairway was very steep, almost like a ladder. It was like going into a dark tunnel. I was usually the only person to go down there to tend the furnace. In the winter time the guys in the shop would holler at me to stoke the furnace so that it would kick out more heat. One guy told me that I should pour a little oil on the coals to make it kick out more heat. In Iowa the winter gets pretty cold and 1955 was an exceptionally cold year. On that Christmas eve day after getting back from lunch I found the guys hollering that it was too cold in the shop. So I took a five gallon can of used oil down to the basement and poured it into the furnace auger. Boy did that make the furnace kick out the heat and plenty of black smoke went up the chimney.

At 4 o'clock that day when I was on my last car wash, the yellow '41 convertible drives into our back lot. I hollered at the guys, "Hey, here is that '41 convertible that I saw at lunch." The owner left the engine running and came into the shop and asked me where was the restroom. I told him it was right around the corner. He thought I said "Down there at the corner." I went on washing my car and staring out the window at his car. He went to the door that was the basement door. He opened the door, stepped in and fell twelve feet down those stairs. There was a five gallon pail of axle grease which was stored on the top stair step which he managed to stick his arm into as he began his fall. When he finally came up the stairs he was covered with grease all over the nice three piece suit and top coat. When he came over to where I was he said some things that I can't write about. He went outside and jumped into the '41 convertible and spun a couple of donuts in our parking lot and broke several windows in our shop door.

The mechanics told the boss that I deliberately sent that man to the basement door so he could fall down the steps. I was told that the man spent the afternoon at the Sportsman's Lodge and by the time he came to the shop he was feeling *no pain*. I think that is what saved him from getting seriously hurt by falling down those stairs. The boss would not believe my story and guess who had to fix those broken windows? Yes, you're right, it was me. I hit my fingers many times trying to pound those little brads into the window sash. It was cold and the putty would not stick. I was there long after everybody left that Christmas eve. I still think all that trouble was worth seeing that beautiful '41 Ford convertible, that first '41 Ford convertible I ever saw.

By The Iowa Country Boy ...AKA Don Durkee

Memo



From the desk of
Wayne Taylor
P.O. Box 73
Napa, CA 94559-0073
Phone/Fax (707) 255-1571

January 10, 2000

To: San Fernando Valley R. G. #040

Dear Regional Group Members,

As your outgoing National Director, I am happy to confirm (what most everyone already knows) that Dennis Keene is replacing me as one of our California directors to the National Board.

Also, it is now confirmed that he will assume the responsibility of liaison between your Regional Group and the National Board.

I appreciate the opportunity I was given to serve your group, and offer a special 'thanks' to those who gave me feedback and encouragement.

Happy V-8ing,

A handwritten signature in cursive script that reads 'Wayne Taylor'. The signature is written in dark ink and is positioned above a faint, light-colored illustration of a classic car, possibly a Ford V8 model, which is visible in the background of the lower half of the page.

ASK YOUR TECHNICAL ADVISOR

Each month we will print the response to the best question of general interest submitted to our technical advisor. Please address your questions directly to John Wolf at 818-789-6201

Question:

At our last meeting a new member told us that he had just bought a 1941 Ford that had been stored in a barn in Merced California since 1958. What should he do to this car before attempting to drive it?

John's Answer:

- (1) Start at the fuel tank and clean the complete fuel system. This includes the tank, fuel line, flex line, fuel pump and carburetor. The carburetor and fuel pump must be taken apart to inspect and clean.
- (2) Remove the spark plugs and squirt automatic transmission fluid into all the cylinders. Then turn the engine over by hand until it turns nice and free. Next, charge the battery or install a new one. Now crank the engine over with the starter to blow out any excess oil. This is a good time to check the compression of each cylinder. They should all be within ten pounds of each other.
- (3) Now you can install the spark plugs, put in fresh fuel and see if it will start.
- (4) If it doesn't want to start check distributor and coil. Repair and replace these as needed.
- (5) Next check the brake operation. Wheel cylinders and master cylinder must be checked. Be sure that the fluid is clean and there are no leaks.
- (6) Now check the transmission and differential grease.
- (7) Lube the universal joint.
- (8) The car is now ready to test drive. Good luck.

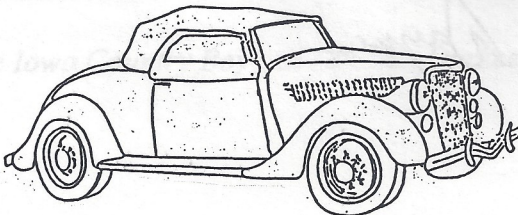

The play list...

Here's a list of cruisin' songs and highway hits inspired by the car culture that got its grip in Los Angeles:

- "Stick Shift," the Duals.
- "Hot Rod Man," Tex Rubinowitz.
- "Hotrod Gang," Stray Cats.
- "Cruisin'," Gene Vincent & his Blue Caps.
- "Radar Love," Golden Earring.
- "Mercury Blues," David Lindley.
- "Maybellene," Chuck Berry.
- "Forty Miles of Bad Road," Duane Eddy.
- "SS 396," Paul Revere & the Raiders.
- "See the U.S.A. in Your Chevrolet," Dinah Shore.
- "Little Deuce Coupe," the Beach Boys.
- "Hot Rod," Collins Kids.
- "Mr. Highway Man," Howlin' Wolf.
- "Lost Highway," Hank Williams.
- "Highway Patrol," Junior Brown.
- "Heavy Traffic Ahead," Bill Monroe.
- "Motorhead Baby," Johnny "Guitar" Watson.
- "Rockin' Down the Highway," Doobie Brothers.
- "Hey Little Cobra," the Rip Chords.
- "Hot Rod Queen," Deke Dickerson.
- "Hot Rod Lincoln," Johnny Bond.
- "Hot Rod Race," Ramblin' Jimmie Dolan.
- "Dragster," Johnny Fortune.
- "Devil in My Car," the B-52's.
- "Rocket 88," Jackie Brenston & his Delta Cats.
- "Key to the Highway," Little Walter.
- "Low Rider," War.
- "Whittier Blvd.," Midneters.
- "Cadillac Assembly Line," Albert King.
- "Crawling From the Wreckage," Dave Edmunds.
- "Dead Man's Curve," Jan & Dean.
- "On the Road Again," Canned Heat.
- "Drive South," John Hiatt.
- "I Gotta New Car," Big Boy Groves.
- "No Money Down," Chuck Berry.
- "Little Forty Ford," Leon Smith.
- "Stolen Car," the Green Hornets.
- "Road Runner," Bo Diddley.
- "Pink Thunderbird," Gene Vincent & his Blue Caps.
- "Sting Ray," the Routers.
- "Route 66 Theme," Nelson Riddle.
- "Gas Money," Jan & Arnie.
- "Gasoline Alley," Rod Stewart.
- "Mustang Sally," Wilson Pickett.
- "Wheels," Flying Burrito Bros.

CARS AND PARTS FOR SALE

Cars For Sale:

1951 Ford ¾ Ton Truck. Basket case, partially restored. Best Offer. Sylvia Campuzano. 818-709-5709

1942 Ford Tudor Sedan. 44K miles. Jim Nycum 818-368-0735

Parts For Sale:

1939 Radio. Repaired \$150; 1939 Mercury NOS Trunk Handle, offer; Lincoln Zephyr starter armature and drive. Late style \$10; 39 standard fuel gauge dash unit \$10; 50 PSI oil sender NOS \$35; New set Offenhauser Heads for 1949-53 engines \$420; Lincoln Zephyr valve springs. The best. \$6 each; Fenton dual manifold with Stromberg 97s and flame arrestors. \$375; Sharp dual manifold with Holley 94s. Mint. \$350; Edelbrock four two barrel manifold to 1948. \$350; Iskenderian full race cam for 49-53 engines. \$65; Winfield F1A cam. 290 degrees duration. \$85; Rebuilt starter with all new parts. \$150, Transmission, side shift with open drive and all new internal parts. \$900; Engine block, 1951 with no cracks. Standard bore. \$500 or offer; Boxes of bolts etc, inquire; 1942 NOS open car antenna \$50. Jack Miles 818-347-8617

Two model 94 type carburetors for V8-60 engine. Dick Stones 805-230-0070

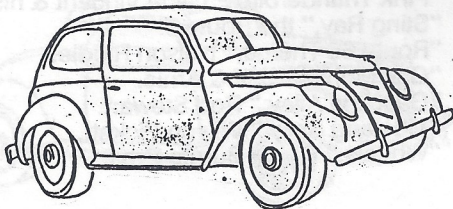

CARS AND PARTS WANTED

Cars Wanted:

1932 through 1940 coupe or sedan. 1932 through 1948 convertible restored or unrestored. Paul Smith 602-489-4504 days or 480-461-3891 eves.

Parts Wanted:

1932 3-window coupe dash, window moldings and other parts. Paul Smith 602-489-4504 days or 480-461-3891 eves.

EARLY FORD V8 TEASERS

This section is intended to tap the combined knowledge of our members and solve some of the mysteries of the Early Ford V8 world. We will reward the member who supplies the most solutions to these teasers, at our December party. Remember, documented proof is required to support your answers.

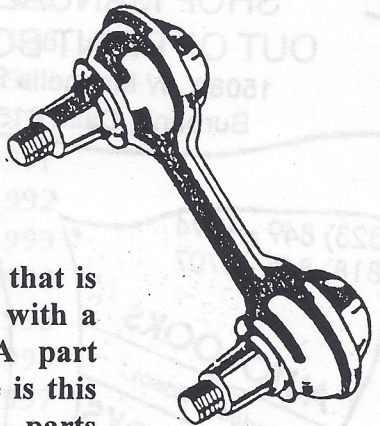

February Teaser:

We have a shock absorber link that is 4.5 inches between the swivels with a Ford script and 11A-18054-A part number in the casting. Where is this part identified in a chassis parts catalogue and what vehicle is it used on?

THESE ADVERTISERS SUPPORT THE VALLEY V8S

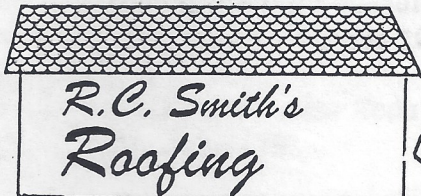

**R.C. Smith's
Roofing**

Roofing & Waterproofing • Complete Maintenance Service

8707-D Lindley Ave., Ste. 199, Northridge, CA 91325
Lic. #356650

**BOOKKEEPING
ADMINISTRATIVE SERVICES**

**INCOME TAX
PREPARATION**

LITTNER FINANCIAL SERVICES

LESLEY A. LITTNER

5051 BLACKPOOL AVE.
OAK PARK, CA 91377



(818) 597-9016
FAX: (818) 597-9145



L.T. "LEE" SAWYER, INC.



Jobber

Shell Oil and Chemical Products

14117 Aetna St. • Van Nuys, California 91401
P.O. Box 369 • Van Nuys, California 91408

**DON'S
Auto Parts**

MACHINE SHOP and BALANCING

Monday thru Friday 8 a.m. to 7 p.m.
Saturday 9 to 6 - Sunday 10 to 4

10241 Woodley (At Devonshire)

**AUTOMOTIVE BOOKS
SHOP MANUALS
OUT OF PRINT BOOKS**

1508A. W Magnolla Blvd.,
Burbank, Calif. 91506

FRED

(323) 849 - 1294
(818) 845 - 0707

AUTOBOOKS
Models & Videos

AEROBOOKS

• ANTIQUE CARS •

ED HARDIN INSURANCE

Business • Life • Health • Aircraft



Call us for your insurance needs!

(818) 363-7864

The Valley

PAST PRESIDENTS

.....

Jim Rowe	1971
Doug Peterson	1972
Don Durkee	1974
Ed Warnock	1975
John Busk	1976
Chip Werstein	1977
Stan Marsraje	1978
Bill Culp	1979
Al Spencer	1980
Larry Caplan	1981
Bob Rose	1982
Don Durkee	1983
Paul Kirk	1984
Kent Lowry	1985
Dave Sanborn	1986
John Kemmerer	1987
Dudley Ochsner	1988
Jerry Jensen	1989
Jerry Jensen	1990
Joe DiFatta	1991
Chuck Shubb	1992
Chuck Shubb	1993
George Richards	1994
Jerry Littner	1995
Dick Smith	1996
Chuck Mair	1997
Dennis Keene	1998
Rose Gott	1999

The Valley 's

10944 Oklahoma Ave. • Chatsworth, CA 91311

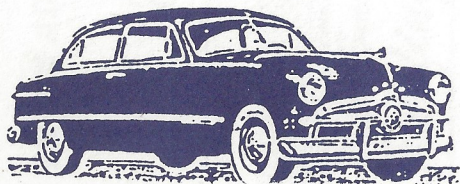

1950 Ford