

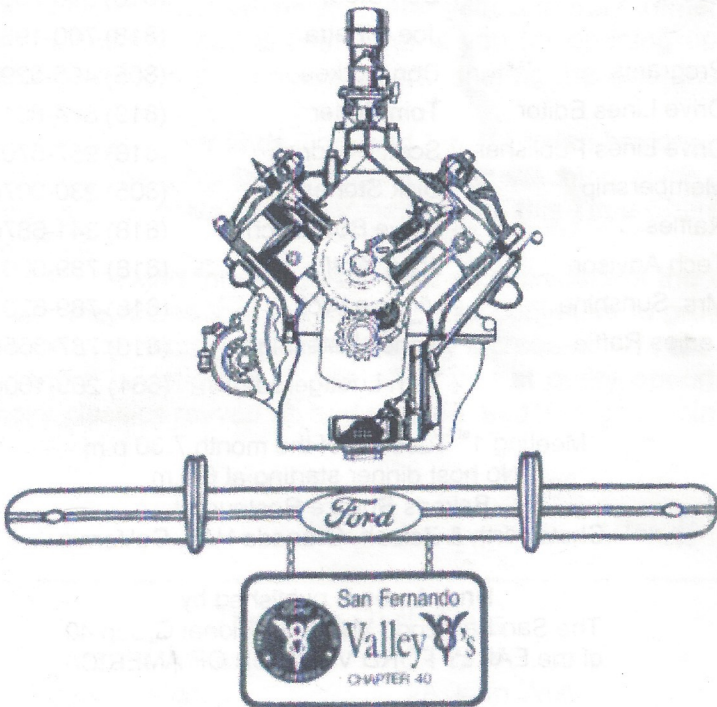

January 2004

"Our 34th Year"



Drive Lines

The Valley V-8's

2003 Officers

President	Wendi Potter	(818) 884-8019
Vice President	Steve Batesole	(818) 787-3658
Secretary	Rachael Doudrick	(818) 957-5708
Treasurer	Ingvar Carlson	(714) 608-5965
Tours	Don Stout	(818) 998-7054
	Joe DiFatta	(818) 700-1939
Programs	Don Durkee	(805) 495-5298
Drive Lines Editor	Tom Potter	(818) 884-8019
Drive Lines Publisher	Scott Doudrick	(818) 957-5708
Membership	Dick Stones	(805) 230-0070
Raffles	Steve Boskovich	(818) 341-6876
Tech Advisor	John Wolf	(818) 789-6201
Mrs. Sunshine	Virginia Wolf	(818) 789-6201
Ladies Raffle	Nancy Batesole	(818) 787-3658
	Terri Luetgerodt	(661) 269-1008

Meeting 1st Tuesday of the month 7:30 p.m.

No host dinner starting at 6 p.m.

Baker's Square Restaurant

Chatsworth & Zelzah, Granada Hills, California

Drive Lines is published by:

The San Fernando Valley, Regional Group 40
of the EARLY FORD V-8 CLUB OF AMERICA

Mailing Address: Valley V-8's

21545 Erwin Sreet #107

Woodland Hills, CA 91367

Wendi's Whimsical Notes

— January 2004 —

Happy New Year to one and all. I do hope everyone had an enjoyable holiday season. For those who attended the Valley V8 Holiday Party on December 7th, we had a "wonderful" time bringing the V8 year to a close on a very high note. It was quite the event extraordinaire. Doughnut anyone? Again a special thanks goes to the many who assisted in making this party the success it was. Your support was needed and greatly appreciated. As usual the Boskovich Open House was delightful. Steve and Sue really out do themselves year after year with their tremendous display of holiday decorations. Thank you for opening up your beautiful home to the membership and sharing the warmth of the season.

The New Year finds Tom and I in Mazatlan basking in the sun, strolling the long sandy beaches and watching some of the most beautiful sunsets ever imaginable. Ah, this Time-Share stuff is so worth it.

I am looking forward to my year as President of the Valley V8's, with the hopes that the membership continues to grow and involvement in monthly activities steadily increases. We are a fun bunch and it is delightful to see all of you at every opportunity. Get those classics revved up and running, and let's go crusin'.

Best,

Wendi

January Birthdays

- | | |
|--------------------|----------------------|
| 1 Barbara Williams | 24 Don Dupree |
| 3 Jean Welch | 25 John Wolf |
| 4 Barbara Wright | 25 Lu Anne Rohrer |
| 10 Leon Nitz | 26 Barbara MacMillin |
| 14 Ken Smith | 27 Don Zable |
| 19 Jack Miles | 27 Rachael Doudrick |
| 22 Eileen Kaplan | 28 Jerry Littner |

January Meeting Tuesday, Jan. 6 Baker's Square

Zelzah and Chatsworth, 7:30 PM. Come early. Have dinner with V-8 friends starting at 6 PM. Bring a guest and enjoy the start of our 2004 year. It could prove to be V-8 Fun at it's best. Bring that Flathead V-8 unless it's raining. Let's make the parking lot shine.

Calendar

JANUARY 24. TOUR: Mike Fennel's Restoration Shop, Santa Clarita. Meet at Woodley Park at 9:15 AM. Leave at 9:30 sharp. Arrive at Mike's Shop by 10:00. Tour takes about two hours. Includes some very rare and expensive cars such as one being restored for Pebble Beach. Look for the '50 Merc two door that can or should win a Rouge award as it stands right now. See page 12 for a tour preview.

We lust for this beauty each time we see it. We go from there to Lunch at the Historic Saugus Café, the place where actor James Dean (Rebel Without a Cause) was last seen alive on the fateful night of his death in a car crash.

February 3rd. 7:30 PM, February Meeting at Baker's Square. Our Program will be an interesting presentation by Sgt. John Artez of the Los Angeles Police Department, Auto Theft Division. He will discuss the where and why of quto theft and what we can do to prevent it. We believe this will be one that we will all enjoy. Bring a Friend!

February 7th Nick Alexander's Swap Meet and Car Show. Downtown Los Angeles. Details to follow next month.

Special for January Drive Lines

This is a special issue in many ways. BUT, because there is so much material and not enough space, we are NOT including some of our regular features. There will be no Want ads or Car of the Month in January due to the lack of a regular December meeting.

Other items such as Believer, will be absent, not because we plan to make a permanent change, but because we are constantly watching the budget and the space limitations. Thanks.

TP

PROGRAM FOR THE JANUARY MEETING



Ron Cunningham will be our speaker at the January Meeting. This fascinating man will share the "unclassified" highlights of his career in defense intelligence. Ron has had two full careers, the first for 24 years as an Air Force officer in R&D assignments, and the

second for 22 years at R&D Associates.

His research in the Air Force covered corrosion prevention in jet engines. At the Defense Atomic Support Agency, he worked closely with Los Alamos, Livermore and Sandia Labs on nuclear weapon design. He was a consultant to the Joint Chiefs of Staff during the Cuban Missile Crisis and wrote a comparison of the US and Soviet weapons programs.

At the Defense Intelligence Agency, he worked closely with CIA, NSA and on National Intelligence Estimates of foreign missile and weapons programs. He has also worked with the DIA Scientific Intelligence Advisory Committee and the President's Foreign Intelligence Board.

At Air Force Systems Command he was head of the Weapons Division, He was one of two Colonels who developed a new program for High Energy Laser Weapons. His last Air Force assignment was as Commander and Director of the Air Force Weapons Laboratory in Albuquerque, NM. During his three years there, the first high-energy laser was installed in an aircraft, which then shot down air-to-air missiles. The first combat use of the Daisy Cutter was in Afghanistan.

Leaving the Air Force, he joined R&D Associates, an offshoot of RAND Corporation, and conducted research on military crews under extreme stress.

We look forward to hearing Ron. Because of the nature of this presentation, we are expecting that the program may run a little longer than usual at our January meeting. **THIS IS A DO NOT MISS MEETING! TP**

Two 2004 Tours you won't want to miss!

1. 2ND ANNUAL TRIP TO LAUGHLIN, NEVADA. Stay at the Colorado Belle Hotel and Casino.

WHEN? Depart Friday March 26, 2004 at 10 AM

Return Sunday, March 28 at 6 PM

Prices are \$85 PER PERSON DOUBLE OCCUPANCY. SINGLE ADD \$37.50 This includes transportation with juice and doughnuts on Friday, Two nights lodging at the Colorado Belle, one choice buffet, baggage handling, snacks and drinks on bus, Friday Bingo with cash prizes, Sunday Movies and naps.

For further information Call: STEVE BOSKOVICH (818)341-6876. This is our March Tour and a TON of fun!

SIGN-UP WILL BE AT THE JANUARY MEETING

2. 1ST ANNUAL BIG BEAR LAKE ANTIQUE CAR SHOW

WHEN? August 13, 14, 15, 2004

THE BIG BEAR FUN RUN is sponsored by Big Bear Lake Antique Car Club. We will drive our V-8s up to Big Bear on Friday, Aug.13. There will be a Poker Run and barbeque on Friday night and Car Show and tour of Lake on Saturday, followed by a Street Dance with band in the evening. Pancake breakfast and awards ceremony on Sunday morning.

If you would like to receive the registration flyer for "FUN RUN 2004", send a self-addressed, stamped envelope between January 1, 2004 and February 1, 2004 to:

BIG BEAR LAKE ANTIQUE CAR CLUB

C/O FUN RUN 2004

P.O. BOX 6311

BIG BEAR LAKE, CA 92315

Make your reservations NOW!! for Friday and Saturday night at the Black Forest Lodge, just three blocks from town. Their phone number is (800)255-4378. The rooms are not blocked off, so make the reservation in your name. Cost per night is \$85.00. The entire town of Big Bear Lake books up fast so don't hesitate. You do not have to enter the car show to go on the tour.

Keep in mind that the BIG BEAR FUN RUN is very popular, and since they are limited by the number of parking spaces available, they usually fill up in less than four weeks from the mailing of registration papers. The FUN RUN flyers will be sent out the first week in March.

For more info: call Steve Boskovich at (818)341-6876

Suggestions for 2004 Tours and Activities

The following is a tentative list of tours by month. Except for the January item, which is firm, everything on this list is still very much up in the air. We are publishing this list, in part, because you may want to consider some of our plans on your calendar of exciting events.

We want member input. Please send us notes regarding any item on this list. We would particularly like to hear that: "I want to help plan or arrange this tour." Or, "Let me suggest that in addition to what you have listed..." Contact us (Wendi) at (818) 884-8019 OR contact the Tour Coordinators directly: Joe DiFatta (818) 700-1939 and/or Don Stout (818) 998-7054. Thanks for your support.

Wendi

January 24th	Mike Fennel's Automotive Restoration Shop, Valencia. Saugus Café afterward for lunch See below for details
February 7th	Nick Alexander's Swap meet and car show.
March 26-18	Laughlin (Boskovich)
April	Willow Springs revisited (Farrar)
May	Otis Chandler
June	Petersen Museum
July	Solvang (DiFatta)
August 13-15	Big Bear Fun Run (Boskovich)
September	Water Plant (Luettgerodt), Annual BBQ (DiFatta)
October	Ft Tejon Civil War reenactment
November	C&G Open House / Deer Park near Temecula
December	6th-Holiday Party and Boskovich Open House (date TBD)

Note the dates above IN PENCIL. Plan ahead for these Ford Events!



Dick Colarossi

C Q AUTO PARTS INC.

We Specialize in Service

21116 Devonshire St
Chatsworth, CA 91311

Telephone
818 341-3121

Valley V-8s Holiday Party



There were a lot of V-8ers, there was a lot of food, there was a Holiday atmosphere and there were a some funny, perhaps, embarrassing moments. It was the 2003 Valley V-8 Holiday Party. What a BASH!

We all, that is, about 85 members and guests, gathered at Encino Glen on December 7th. The place looked beautiful and the fun began. There were raffle tickets to be sold. Thanks Steve Boskovich! There were raffle prizes. Weren't they the best? BIG thanks go to Virginia Wolf and her helpers Joan Sapper and Carole Jensen. There were decorations everywhere. Special thanks go to Christine and Rachael for the center pieces and décor on the tables. The room decorations were ably hung by all working together including, Karen, Dave, and Tom. There was a superb video of still shots from the 1940's film, "It's a Wonderful Life," which was our theme for the party. Thanks to Scott Doudrick for the smooth running power point presentation on the big screen. Drive Lines was there with the "2003 Retrospective in Photos". Thanks to Dudley Ochsner for his beautiful invocation that even included the wish that God help our Fords from overheating!

Then there were all the things that made a good party into a great one. The band including the dancing, the food service (it was delicious!), and the quiz about the 1940's "Wonderful Life" theme from school teacher, Wendi. Those who got all the answers right got an "A" in the class and prize gift certificate!

As is our custom, the new officers for 2004 were sworn in, this year, by John Kemmerer. This included, as in the past, the now famous rendition of "So help me Henry." If Henry Ford isn't rolling over in his grave, it is not our fault!

Now, about a certain delivery from Krispy Kreme donuts... This started off as an innocent request from VP Wendi, to a certain Mr. Durkee, to wear a donut costume and present a gift to the out-going President, Joe DiFatta. "Leave it to me," says Don... It is safe to say that what happened after that was not in Wendi's original plan. A refrigerator box was "brought front center" by Ron and Steve Batesole. When the brown paper

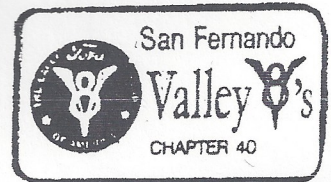

Hello Ford flat-head fans!

Do the sounds and feel of Ford flatheads get your attention? Do you want to work with and drive these great cars? Maybe you would enjoy meeting with a group of people who feel the same way. The Valley V-8's invites you to come to one of our meetings to get acquainted or join us on one of our monthly tours. If you don't own a flathead V-8, you may wish to bring a modern car on the tour.

The club meets on the first Tuesday of each month at Baker's Square near the corner of Zelzah and Chatsworth in Granada Hills at 7:30 pm. Many of us gather for dinner about 6:30 at the restaurant. We have a great time sharing our interests in Fords, Mercs and Lincolns built between 1932 and 1953. We take tours to many places of interest in California and sometimes beyond, in our flathead V-8s.

After your visit, if you care to join, fill out the form below and return it with \$28.00, annual dues, to our Membership Chairman:

Dick Stones
1405 Valley High Ave.
Thousand Oaks, CA 91362

Name _____ Spouse _____ Meeting Dates 2004
First Last

Street address _____ April 6

City _____ State _____ Zip _____ May 4

PHONES: Day (____) _____ Home (____) _____ June 1

Occupation _____ Month/Day of birth _____ July 6

Spouse's day and month of birth _____ Aug. 3

Flathead vehicles owned: _____ Sept. 7

_____ Oct. 5

_____ Nov. 2

Year	Make	Model	Body Style

Local chapter members must join the **Early Ford V-8 Club of America**. Please mail your membership to **PO Box 2122, San Leandro, CA 94577** with you check for \$32.00 annual dues. Hope to see you at our next meeting. Please don't hesitate to call me days or evenings at (818) 535-4045.

Ingvar "Swede" Carlson
 Treasurer, Valley V-8s.

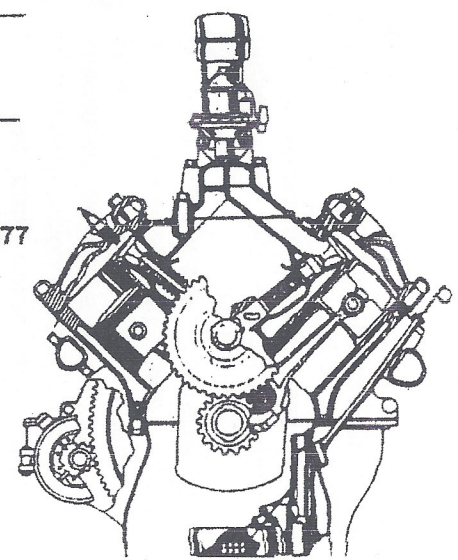

wrapping was removed, we found that the box was indeed, covered with very authentic looking Krispy Kreme Donut logos. The colors and lay out were convincing.



What happened next is a little unclear, but, according to witnesses, a "girl donut" somehow emerged from the box and there were some questionable approaches seemingly made by said "girl donut" to certain club officers in the attempt to "deliver" a holiday gift. When all the commotion died down, the blonde wig was cast aside, the mask was removed, and the "girl" turned out to be Mr. Durkee himself, playing the role. Some have said, he was, indeed, the main perpetrator of the hoax. The chaos

was considerable, but there were no injuries reported. There was, however property damage, as the Krispy Kreme box got wet from the rain, on the return trip to Thousand Oaks in the back of Durkee's '40 Ford pickup. It had to be destroyed. It seems that all was forgiven, in the end, and by virtue of his authority as club President, Joe DiFatta forgave Durkee and reinstated him in his post as a respectable program coordinator, or something to that effect.

A good time was had by all and the first of two parties ended with everyone enjoying a great evening. Our Holidays were beginning and another official year for the Valley V-8s came to an end. We now have a board ably led by President Wendi Potter which includes many of the fine officers from 2003.

We especially want to thank Wendi for coordinating an excellent Holiday Party and, in the spirit of the New Year, wish her a great year as President for 2004. We send all members and their families joy and the hope that there are many good meetings and tours in your future with the Valley V-8s. TP.



The Valley V-8 Christmas Party at the Boskovich's Home



On December 11 at about 6:PM we started arriving. Steve and Sue's home was like a fairyland. Each room was decorated in tasteful Christmas trimming and more. The ambiance was amazing, as each room seemed to turn one into a child who was looking at a toy store. During the war, when I was in elementary school, there was no steel, therefore, no bicycles, no electric trains and no "good" toy cars. The plastic and cardboard toys were, well, not what I dreamed of. By the time the war was over

and my dad was back from the Army, he was going to school on the GI Bill and we didn't have the money to buy all the things that I wanted that had become available.

The Boskovich home, made all those real life experiences just seem like a forgotten memory. Now it was all here in front of me, almost like I could play with each toy. I could get down close and see the toy cars and lighted villages. The store fronts were very realistic and there seemed to be a Christmas tree, large or small in every room. I suppose, a girl would get just as excited about the huge doll collection. The Christmas Spirit was everywhere.



When I arrived, Steve told me there were eight flathead V-8 Fords and Mercurys in the house. I found all of the toy cars and trucks, most of them in a setting fitting to their size and use depicting the Good Old Days.

To top it off, there was great food, especially the desserts! I just kept coming back for more. How many of us have said, "I'll start my diet tomorrow?" I sure did. Did you know that Blacky plays a very mean piano? This guy is really good and he has been hiding it, at least from me. We'll get him involved in the Club

music program! Do we have a club music program? Well, maybe, we ought to!

Some of us were in the patio, some in the living room and the kitchen. The dining room and even in the well decorated bedrooms. We even wandered into the garage where there is an incredible '51 Ford convertible, the one that won best of show at Big Bear last summer. All of us were having a grand time until late when we wrapped it up with a "Merry Christmas!"

Thank you Steve and Sue for keeping up this great V-8 tradition. We look forward to visiting you home next year. It just keeps getting better and better. Happy Holidays!

Can You Hear us at the Meetings?

We've noticed that as our club grows, it is harder for all the people attending to hear what is going on "up front." Being the "Action Types," we decided to do something about it. Starting at the January meeting, we will be using a PA system and microphone for all those addressing the club. This excellent unit has been donated to the Club by Chuck Mair. Please help us place the speaker and adjust the volume our "first time out" with this unit to the best advantage for your enjoyment of our activities. We want everyone to hear without disturbing the restaurant. We'll check it out early in the meeting on January 6. A big V-8 THANKS goes to Chuck for this donation. It is much appreciated especially by those who don't get here early enough to have to sit in the first three rows. That means about 90% of the club. Do you realize how big we have become?

My Second '50 Ford Coupe

By Don Durkee

This story starts in the Fall of 1979. I had just started working for Kemp Ford. Frank Williams Sr. had asked me to look at a car with him when I got off work that day. It was a 1940 Maroon Ford Convertible with a Columbia axle. I was surprised that there was another '40 Ford Convertible in Thousand Oaks. Frank and I went over to Lynn Ranch to look it over. As Frank was making the deal to buy the '40, I noticed a restored '50 Coupe sitting in a corner of a horse barn, tucked away almost out of site.

After Frank made his deal, I asked Rudy, the owner, about the Maroon '50. He said he never drove it after it was restored but it was not for sale.

Fast forward to the Spring of 1989. I was still working for Kemp Ford when I received a strange call. "How much are you gonna give me for the coupe?"

I replied, "I don't know who I am talking to and I don't know what coupe you are talking about."

The reply was, "You know, the maroon coupe you were looking at over here a while back. This is Rudy. What are you going to give me for the coupe? It is for sale."

I asked him, "How much?"

He said, "You tell me!"

I said, "It has been ten years since I saw that car!" He was very pushy about me giving him a price. He said it was the same as when I saw it. I offered him \$5000. He told me that I should know it was worth \$10,000, but he also said I should come over and look at it when I got off work Wednesday night.

I rushed over to his place to see the car. I found that there was ten years of dust on the car and a dent in the front door and fender because they were too close together. Every time you opened the door, it would hit the fender. The chrome on the bumpers had green corrosion from sitting in that horse barn.

I told him that the car needed to be painted and the bumpers rechromed to which he agreed. Now, as I said, Rudy was a pushy sort of guy and wanted to know how much I would give him for the car "NOW!" and, he added, "It has to be more than \$5000!" *To be continued....*

This is the first of a series of articles by Don Durkee on another of his "Famous" cars. Stay with us for all the details in the coming months. TP

Retrospective on 2003:

What have we been up to??

January	JPL Tour, Greater LA Auto Show
February	Nick Alexander's Swap Meet and BBQ
March	The First Annual Laughlin / Colorado Belle Trip, Steve Batesole's, "Life of Henry"
April	Leon Kaplan, the Motor Man,
May	Ft. Tejon Tour
June	Gilroy and Santa Cruz Tour
July	Santa Paula Airport Tour / Gilmore House Tour
August	Solvang Tour. Nick Alexander: How to Restore a woody RIGHT.

- September THE Annual Club Auction. Steve Boskovich wins Best Convertible at Big Bear
- October Classic Flathead goes to Pebble Beach. Larry Johnson's Annual Anaheim BBQ
- November 4th Annual End of Summer DiFatta BBQ, Flags, Ft Tejon and U.S. History
- December Great Sacramento Tour, Famous Holiday Party

Cars of the Month At each month's meeting, one car, which is driven to the meeting, is selected by a panel of judges appointed by the President, to be "Car of the Month". In the past these have been cars that are "finished". That means cars that are ready to show. Below is a list of the cars selected in 2003 and the monthly meeting at which they won. CONGRATULATIONS TO THE OWNERS OF THESE BEAUTIES! Enjoy your gift certificates!

- Jan. Don Durkee's '53 Convertible
- Feb. Chuck Mair's '41 Business Coupe
- Mar. Al Rohrer's '40 Pickup
- April Dick Gise's '36 Deluxe 5-Window Coupe
- May Zip Updike's '40 Convertible
- June Nick Alexander's '39 Deluxe Coupe
- July Don Stout's '40 Deluxe Coupe
- Aug. Steve Batesole's '36 Pickup
- Sept. Darryl Thomas' '39 Deluxe Coupe
- Oct. Dick Stone's '50 Custom Club Coupe
- Nov. Allan Franklin's '35 Deluxe 3 Window Coupe

For 2004, it is our intention to ALSO to recognize cars that are driven to the meeting which are not finished and "ready to show", but rather are "cars in progress". This means that the owner is ready to let us see the work that has been done and the work that is yet to be done. He / she may even want to share a little about where the car is and what is the next "step".

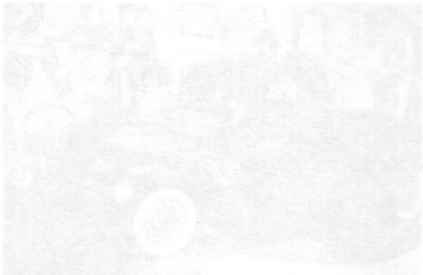

The Latest from the (Nov.– Dec.) “V-8 Times”

Did you notice the Judging Results from the Grand Nationals? A couple of Valley V-8 guys have been out there doing it at the top of the National Competitions! On Pp. 33 – 37 the winners of awards include:

Two concourse awards for Nick Alexander ('33 Station Wagon, '42 Station Wagon)

One Dearborn award for Nick Alexander ('34 Station Wagon)

One Dearborn Walk Around for Don Durkee ('50 Crestliner)

Don Explained at a recent meeting that when the same car wins a Dearborn twice and you bring it in again, and it is still in top shape worthy of a Dearborn, the third time is called a “Walk Around.”

Congratulations Gentlemen! You are among the best in our hobby!

Images from Mike Tenet's Restoration Shop



The Valley's

PAST PRESIDENTS

Jim Rowe	1971
Doug Peterson	1972
Don Durkee	1973 - 1974
Ed Warnock	1975
John Busk	1976
Chip Werstein	1977
Stan Misraje	1978
Bill Culp	1979
Al Spencer	1980
Larry Caplan	1981
Bob Rose	1982
Don Durkee	1983
Paul Kirk	1984
Kent Lowry	1985
Dave Sanborn	1986
John Kemmerer	1987
Dudley Ochsner	1988
Jerry Jensen	1989 - 1990
Joe DiFatta	1991
Chuck Shubb	1992 - 1993
George Richards	1994
Jerry Littner	1995
Dick Smith	1996
Chuck Mair	1997
Dennis Keene	1998
Rose Gott	1999
Don Stout	2000
Steve Boskovich	2001 - 2002
Joe DiFatta	2003

Incoming President / Mendi Potter
Outgoing President / Joe DiFatta with

The Valley 's

21545 Erwin Street #107, Woodland Hills, CA 91367



Outgoing President Joe DiFatta with
incoming President Wendi Potter

