

# Drive Lines

Our 38<sup>th</sup> Year

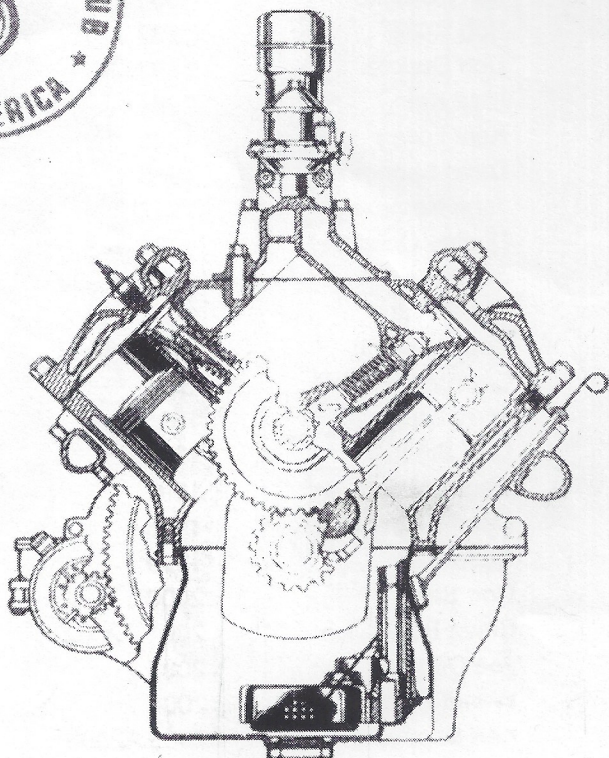

Meeting  
August 5, 2008

Meeting Place: CoCo's Woodland Hills

Meeting Leader: Harry Baker

Carl's Car Count: 11

Start Time: 7:30 Adjournment Time: 9:32

Introduction of Guests: Ashley Bergman's friend Larry Childs.

Treasurer: Wendi Potter: Wendy brought Gerry Blackwell up to tell a joke. She then gave the amount in the treasury, which is recorded in the hard copy.

Tours: Steve Boskovich reminded us the Marina del Rey tour is July 27. We leave from Woodley Park at 8am. The get together at The Hat in Simi is July 17. Camarillo Airport is Aug. 17. This year they want us to bring out cars. Steve thanked all the guys who helped fix his car on the Solvang trip. They wouldn't even let him pay for the part. Tom Potter reported on the Sunrise tour. There were 21 cars. Al Mooney brought 3 cars with the help of his son. A good time was had by all.

Announcements: We need another \$25 donated to the Guide Dogs of America and they will put a tile with Valley V8's on their wall.

Aug. 16 is the Bar-B-Q at the Durkee's house. Sandy Norris told us she the great grandmother to twins. She also told us the wife of Art Hernandez passed away last week.

Car of the Month: Jack Holtwick's '41 Ford pickup

Drive Prize (for bringing your V8 to the meeting) Ken Sapper's '40 Deluxe Tudor

Raffle Winners:

Ladies: Tiffany Bergman and Debbie Bergman

Name Badge: Wendy Potter

50/50 Drawing: \$61 Stewart Campbell

Buyers Appreciation: Chuck Shubb - Ford zipper bag

Program for the evening: Don Durkee told a baseball story about grandson Donny. Then brought up granddaughters Christie and Holly, who told about their dogs. Don introduced Glyn Judson and his dog Harry from the Guide Dogs of America. Glyn is a puppy raiser. Harry is his 5<sup>th</sup> dog. He raises and trains the dogs for service. He has the dog from age 7 weeks to 18 months. His job is to introduce the dog to the world. He wears a yellow jacket that says he is in training when he is out. Glyn concentrates on socialization and obedience training.

If the dog has to do its business, the blind person strokes the dogs back to check his position so he knows if he will need to clean up after the dog. The jacket is removed while the dog takes care of business. The dog will go through six months of formal harness training. During the last 28 days he will work with the blind person. The dogs are always Golden Retrievers. They are in service from 6 to 8 years and then retire. July 27 is the next graduation and only half of the dogs in the program will graduate. The half that doesn't graduate are offered to the puppy raiser, then to a list at the school of people who want them. A blind person in need of a dog, signs up, is interviewed, and submits a video of their ability with a cane. Guide Dogs pays for them to come to the school, the dog, the training, the harness and lifetime support.



Isn't it nice to have the kids be able to come to our meetings and be comfortable and enjoy themselves. Glyn Judson gave us ALL a new insight into Guide Dogs and their training.



Look at Dons face. He's showing us his pride.

## Editors Notes

At our last meeting Dennis Keene told us about a book being put together by the Early Ford Group Chapter #11. It was only Ten bucks and I am a push over for those cheap bargains. I'm so bad I have shopping network making house calls. Anyway I received my book and **I wish to tell you it far exceeds** what any one can describe to you. This is a book that you should have if you do any work on any type of old car not just flatheads. They have all the vendors I owe money to and then some, it is cross filed in three ways and color coded. Because chapter #11 is located further south than our group, a lot of the local suppliers are in that local, but so is C.J.Moss so it's no big thing. They list 193 vendors in the blue part, with those familiar names like Le Baron Bonnie, Flathead Jack and Bob Drake, plus 190 other car specific names. This is a great effort and really a good book to have. Source: Early Ford V8 Resource Guide 3855 E. La Palma Ave. Suite 246 Anaheim, CA. 92807-1748 \$10.00 Plus \$2.70 mailing.

This is my cut it out and past it on a 3 x 5 card for future reference, so you can find it..

---

Front axle nut - tighten to **4 to 6** ft/lbs of torque, then back off one castellation, to achieve a **.004 to .010** hub end play. Be sure to put in the cotter pin

Torque the wheel lug nuts to **75-80 ft/lbs**

Torque the back axle nut to **150/200 ft/lbs**

Add ZDD Plus to your oil each time you change oil, to save your cam and push rods.  
Available from Eastwood and H&H Flatheads and others.

---

I just wanted you to know, I am now entering the Snapdragon part of my life. Part of me has snapped and the rest of me is dragin.

Accept misfortune as a blessing. Do not wish for perfect health, or life without problems. Without them, what would we talk about.

If your friends can accurately guess your age, you should find dumber friends.

Flatulence: Female--An embarrassing by product of indigestion.

Male-- A source of entertainment, self-expression, male bonding.

Communication: Female-- The open sharing of thoughts and feelings with one's partner  
Male-- Leaving a note on the fridge, before taking off in the flathead, for a trip with the boys.



Isn't it nice



This truck is PREMO Every things there all it needs is a little love and a splash of paint and WOW.

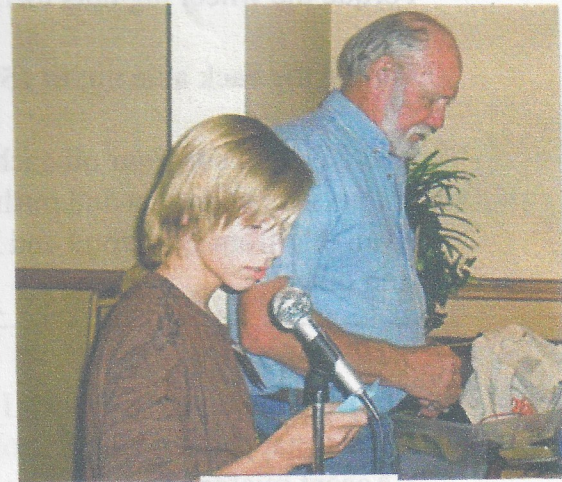

AW! come on gang it is July 4Th

Isn't it nice



## FOR SALE

1940 California License plates. DMV Cleared, Nice condition. Do not need to be restored \$ 200.00. ask for Craig Lapair day phone number 818-893-1640 cell 818-399-7259 (corrected phone information **Opps**).

## FOR SALE

Chev Big block hi riser duel manifold, new with carbs \$ 500.00 Ask for Allen Porter 818-367-2890

## FOR SALE

1947 Flat head engine, Turnkey complete rebuild 59a, **Run-IN**. \$ 4500.00

1940 Rearend assy. \$300.00. Ask for Dave Gott 818-767-6153

## FOR SALE

Ford Tri Power with air cleaner. Complete with linkage. \$1500.00. Ask for Jerry Littner 818-597-9016

## FOR SALE

Chev Blazer 4 wheel drive Ask for Art Bergman 818-881-7266

## Up Coming events Valley V8s sponsored in Bold

Aug. 8-10 Big Bear Fun Run details 909-239-7867

**Aug. 16 Don Durkees Fabulous Bar B Q** 736 Brush Hill Rd. Thousand Oaks, CA

**Aug. 17 We have been invited to bring our cars to be displayed at the Camarillo Air Show.** We will meet at Denny's restaurant in Woodland Hills (Topanga Bl. north of the Ventura Freeway) and Leave at 8:00 am **SHARP**. We need to arrive at the East Gate of the airport at 8:30 am. There will be a sign-up sheet at the meeting.

**Sept. Meeting is our BIG Auction Nite** Start getting out the good stuff and shine it up now.

Sept. 6 Foothill Festival of Cars in La Crescenta Details 818-249-5832 or [www.fbcic.org](http://www.fbcic.org)

Sept 18-21 Route 66 Rendezvous in San Bernardino details [www.route-66.org](http://www.route-66.org)

Sept. 21 BIG automotive Swap Meet at the Mid State Fair Grounds in Paso Robles, Ca details Robert 805-238-7505 (Fellow Early Ford V8 Club Chapter 135 Atascadero region)

**Dec 7 2008 Valley V8 Holiday Dinner**

THE TWELTH ANNUAL  
**AUTOMOTIVE  
SWAP MEET**

MID-STATE FAIRGROUNDS  
Paso Robles, California

Sunday - September 21st, 2008

7 AM - 2 PM (Set-Up Saturday, September 20th, 12 Noon on)

All Makes - Antiques - Vintage - Special Interest -  
Autos - Parts - Services - Memorabilia - Collectibles

Space Rental:	20 X 20 - \$25 <sup>00</sup>
Car Corral:	10 X 20 - \$10 <sup>00</sup>

RESERVATIONS AVAILABLE  
PRE-PAID ONLY  
POSTMARK DEADLINE SEPTEMBER 8<sup>TH</sup>  
P. O. BOX 1911  
ATASCADERO, CA 93423

INFORMATION  
ROBERT @ 805 238-7505

ADMISSION FREE  
\*TO BUYERS

← SWAP MEET

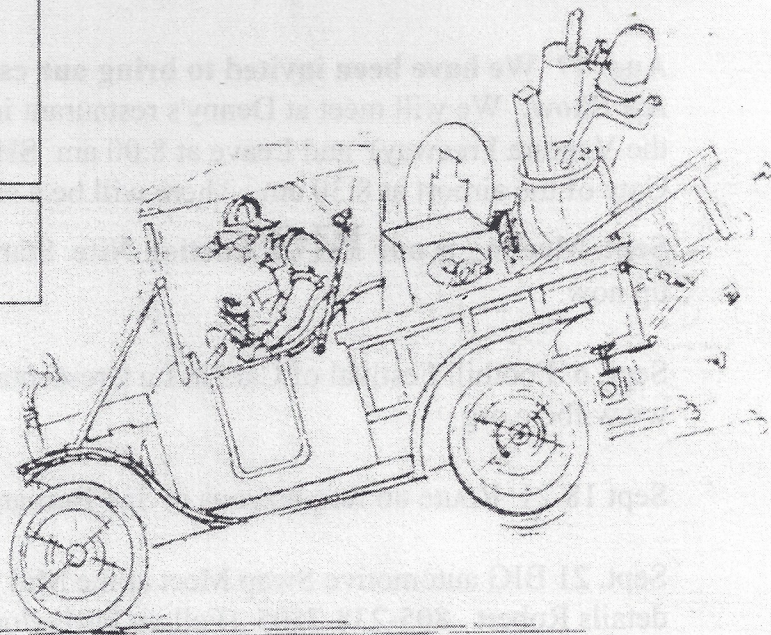

SPONSOR:

**THE EARLY FORD VS CLUB**  
ATASCADERO REGIONAL GROUP #135

# The Valley 's

## 2008 Officers

President	Harry Baker	(818) -705-3930
Past President	Steve Batesole	(818) 787-3658
Vice President	Dave Bergman	(818) 703-0756
Secretary	Karen Lehman	(818) 885-6938
Treasurer	Wendi Potter	(818) 884-8019
Tours	Steve Boskovich	(818) 341-6876
Programs	Don Durkee	(805) 495-5298
	Joe DiFatta	(818) 700-1939
Drive Lines	Jim Kelley	(310) 823-6020
Membership	Dick Stones	(805) 230-0070
Raffles	Helen Baker	(818) 705-3930
Tech Advisor & 50/50	John Wolf	(818) 789-6201
Mrs. Sunshine	Virginia Wolf	(818) 789-6201
Ladies Raffle	Joan Sapper	(818) 249-5686
Historian	Dave Sanborn	(818) 709-0741
Web Master	Scott Doudrick	(818) 957-5708
Car Count	Carl Batesole	

Meeting 1<sup>st</sup> Tuesday of the month 7:00 p.m.  
 No host dinner starting at 6 p.m.  
 Coco's Restaurant  
 22200 Sherman Way, West Hills, California

Drive Lines is Published by  
 The San Fernando Valley, Regional Group 40  
 of the Early Ford V-8 Club of America  
 7822 West 79Th Street  
 Playa Del Rey, Ca. 90293

# The Valley 's

## PAST PRESIDENTS

Jim Rowe	1971
Doug Peterson	1972
Don Durkee	1973 - 1974
Ed Warnock	1975
John Busk	1976
Chip Werstein	1977
Stan Misraje	1978
Bill Culp	1979
Al Spencer	1980
Larry Caplan	1981
Bob Rose	1982
Don Durkee	1983
Paul Kirk	1984
Kent Lowry	1985
Dave Sanborn	1986
John Kemmerer	1987
Dudley Ochsner	1988
Jerry Jensen	1989 - 1990
Joe DiFatta	1991
Chuck Shubb	1992 - 1993
George Richards	1994
Jerry Littner	1995
Dick Smith	1996
Chuck Mair	1997
Dennis Keene	1998
Rose Gott	1999
Don Stout	2000
Steve Boskovich	2001 - 2002
Joe DiFatta	2003
Wendi Potter	2004
Ken Sapper	2005 - 2006
Steve Batesole	2007



The Valley 's

7822 West 79Th Street Playa Del Rey, Ca 90293

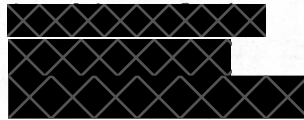

5132633049 0013

