

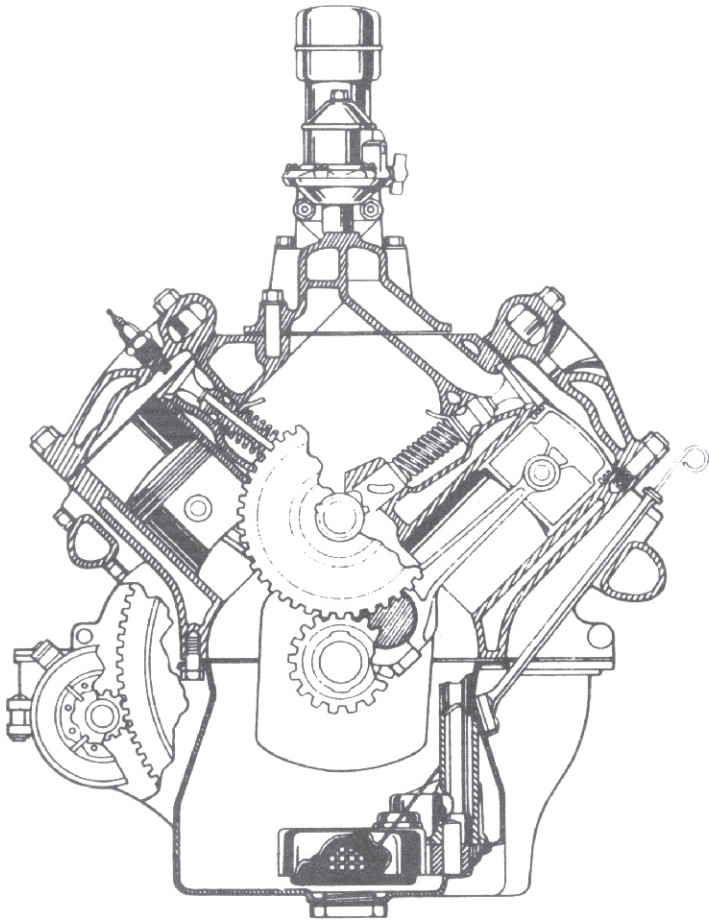

Drive Lines

Chapter #40
Our 47th Year
Visit Our Website
"valleyV8s.org"

February 2018



The Valley V8's
9700 Farralone, Chatsworth, Ca. 91311

The Valley V's

2018

President	Vaskin Hagopian	323-661-2044
Past Presidents	Don Durkee	
	Stan Miller	818-360-4812
Vice President	Steve Lehman	818-885-6938
Secretary	Rex Jaramillo	818-254-8452
Treasurer	Joan Sapper	818-249-5686
Tours	Kenney Sapper	818-249-5686
	Rich Carter	708-567-2393
Programs	Larry Caplan	818-363-2849
	Joe DiFatta	818-700-1939
Membership	Jerry Littner	818-632-9017
	Joan Sapper	818-249-5686
Drive Lines	Robert Glucksman	818-618-1395
	Jim Kelley	310-795-0704
Prize Raffle	Steve Boskovich	818-341-6876
50/50	Ken Sapper	818-380-5686
Ladies / Birthdays / Sunshine	Bobby Searl	818-353-6767
Name Badge	Karen Lehman	818-885-6938
Car of the Month	Jerry Jensen	805-491-3355
Web Master	Scott Dudrick	818-687-9836
Tech. Advisor	John Wolf	818-789-6201

Meeting: 1st Tuesday of the Month, 7:00p
No host Dinner, Starting at 6:00p
Rosie's BBQ & Grill, 8930 Corbin Ave.
Northridge, Ca. 91324

Visit our Web Site: valleyv8s.org

Drive Lines is Published by
The San Fernando V8's Regional Group 40
of the Early Ford V8 Club of America
9700 Farralone, Chatsworth, Ca. 91311

The Valley V's

Past Presidents

Jim Rowe	1971
Doug Peterson	1972
Don Durkee	1973-1974
Ed Warnock	1975
John Busk	1976
Chip Werstein	1977
Stan Misraje	1978
Bill Culp	1979
Al Spencer	1980
Larry Caplan	1981
Bob Rose	1982
Don Durkee	1983
Paul Kirk	1984
Kent Lowry	1985
Dave Sanborn	1986
John Kemmerer	1987
Dudley Ochsner	1988
Jerry Jensen	1989-1990
Joe DiFatta	1991
Chuck Shubb	1992-1993
George Richards	1994
Jerry Linner	1995
Dick Smith	1996
Chuck Mair	1997
Dennie Keene	1998
Rose Golt	1999
Don Stout	2000
Steve Boskovich	2001-2002
Joe DiFatta	2003
Wendi Potter	2004
Ken Sapper	2005-2006
Stever Batesole	2007
Harry Baker	2008-2009
Dave Bergman	2010
Randy Watson	2011-2012
Steve Boskovich	2013-2014
Stan Miller	2015
Don Durkee	2015
Vasken Hagopian	2016-2018

2018 DUES ARE DUE NOW

**PLEASE SEND YOUR DUES FOR 2018 BEFORE FEBRUARY 15TH
WE PLAN TO GO TO PRINT ON THE 2015 DIRECTORY IN MARCH
SO THAT YOU WILL HAVE IT BY APRIL**

DUES ARE \$35.00

PAYABLE TO: Valley V-8Es

**PLEASE FILL OUT THE DUES RENEWAL FORM FOUND IN THIS ISSUE
OF
THE DRIVELINES AND SEND IT ALONG WITH YOUR CHECK TO:**

HARRY BAKER- 5004 ENFIELD AVENUE- ENCINO, CA. 91316

MEMBERSHIP CHAIRMAN HARRY SAYS:

PLEASE DON'T MAKE ME SEND THE FLYING MONKEYS AFTER YOU

THANK YOU.

Chapter 40 -- San Fernando Valley V-8's Club

Monthly Meeting Minutes for Tuesday Jan. 2, 2018

7:00 pm: Meeting called to order

President Vasken Hagopian welcomed the group to the first meeting of the New Year 2018, then led us in the Pledge of Allegiance.

Guest Introductions: The following guest was present: Matt Watson, Randy Watson's son.

Opening comments by our President: 1) Model T anniversary: On Saturday Jan. 20, the Automobile Driving Museum is hosting a celebration for the 110th anniversary of the Model T. 2) Classic Auto Show: Friday Mar. 2 thru Sunday Mar. 4 at the LA Convention Center. We've been asked to help set up a display of Early V-8 Fords. This would be free for the participants. 3) Dearborn event: This is the year for the grand national meet for V-8 National level. So during the week of June 11 through 15, 2018, there will be one Dearborn Event. It will be held at the Edwards Hotel in Dearborn, MI. 4) New members needed: There was a nearly 2% decline in Early V-8 Club National membership last year. We all need to encourage younger people to join our ranks. 4) Give your Ford recognition: The third Saturday in June (June 16, 2018) has been designated the National Drive Your Ford Day. 4) Sad news: We lost our good friend and long-time Club member Randy Watson recently. He had quite the background, including Commander status in the military, and, get this: He was an F-4 jet fighter pilot! And who can forget his mighty fine 1948 Ford convertible. Following him back from one of our cruises, lets just say that he drove it like he flew his planes, you get it! Quite a guy, our friend Randy. 5) New board members: Harry Baker, Membership/Directory officer, and Robert Glucksman, Driveline Editor. 6) New laws for motorists, 2018: These pertain to transportation funding (increased gas and diesel taxes), marijuana-impaired driving, disabled placards, smog check fees, and parking. The handout Vasken provided us has more information.

Reports from Officers:

Secretary's report – Rex Jaramillo – Everything OK.

Treasurer's report – Joan Sapper – Everything OK. Joan gave a Club financial report for year 2017.

Editor's report – New Editor Robert Glucksman. Thanks, Robert for stepping up. And hats off to Jim Kelly for doing an outstanding job as Editor for many years. Remember 'one more year'! Thanks, Jim.

Membership report – Harry Baker is our new Membership officer, thanks for doing this. And thanks to Jerry Littner for doing a great job before him!

Tours report – Ken Sapper gave a report. He is talking about some very interesting possibilities, including San Antonio winery. Stay tuned, Ken's got some swell ideas!

Other Announcements:

7:30 pm: Break called

7:45 pm: Meeting resumed

Vasken mentioned the following: 1) Christmas Party, 2018: mentioned we're considering a different location, and maybe a luncheon vs. dinner. 2) Meeting: Jan 18, Club board of director's, Boskovich residence.

Car of the Month: Handled by Jerry Jensen: Won by Ken Sapper's '40 Ford. Check it out, no flaws on this one! In fact, this car has the distinction of winning an Early V-8 Ford Club of America Dearborn Award. So Ken has reason to be proud, It took him many years to restore this completely stock beauty to its present level of perfection. Congrats, Ken, an award well deserved!

Ladies raffle: Handled by Bobby Searle. Won by Reenie Jaramillo and Judy Schubb,

Birthdays – For December: Ron Batesole, Jim Dawson, Ken Sapper. For January: Sandy Norris, David Crockett, Joe Longobardi, Rachel Doudrick, Blake Wilcox, and Scott Cramolini.

Name Badge: Won by Ernie Baily.

50/50 Drawing: Won by Stan Miller.

Program: Tonight some of our Club members had the opportunity to share about who they are and how they got into old Fords. Each one was introduced by Larry Caplan, it was an interesting evening. **Harvey Jacobs:** Remember his swell blue '51 Ford convertible? Well that wasn't his first. Here's the deal: Harvey 'inherited' a '47 Plymouth from an older sister, dependable but not cool enough for a 16-year old boy. So he latched onto a '51 Ford convertible, baby blue, three speed with overdrive. Now that's cool! Fast forward a few years and check out his present '51, she's a beauty! Harvey has had 'er for about four years. He also has a late '31 Ford Model A Town Sedan that he acquired in 1974. A well rounded collection! **Robert Glucksman:** Robert is our new Drivelines editor. His association with old Ford's started in a casual way when he started attending the Thursday morning donut club.

Robert has the distinction of owning the newest early Ford in our Club, a really swell 1955 Ford Mainline. He bought this car from another club member and never looked back. It's all original with the factory drivetrain, the *Mileage Maker* 223 cubic inch Ford overhead valve 6-cylinder engine backed by a 3-speed stick with overdrive. For 1955, Ford applied 3:89 gears at the rear for this driveline package, so this Ford has plenty of suds stoplight-to-stoplight. And it's dependable. No muss, no fuss, it fires right up every time, one swell Ford. Now Robert is an artist by trade, but a very distinguished one. He has worked for many companies, but the most noteworthy is Revell, yep, the model car company. You know the graphics you see on the model car boxes? That's the handiwork of Robert! So he's the go-to man for anything pertaining to model cars. **Jim Kelly:** Just after graduating from high school, young Jim and his brother, an Air Force P-38 pilot, drove a '40 Ford convertible across country from Chicago to California. Now this wasn't your average cross-country trip, you understand. We're talking 1941, just after our country had joined the Allied Forces war effort. Rationing our precious resources including gasoline to support the war effort was the by-word. However the boys were able to acquire gas to keep going until they arrived in Albuquerque, kind of late at night. Now they needed gas for that fine, still fairly new, '40 Ford. So they did the best they knew and pulled into a gas station that was closed, and started 'draining' the hoses. Now remember, there was rationing going on, and the hour was late. A police officer pulled up, asked them what they were doing, of course he knew. So he ordered them back into their car, told them to follow him. Moments later they ended up at the police station, they really thought they were in trouble! After a lengthy lecture, the stern-faced officer led them to some gas pumps, and let them fill up their gas tank! Again a stern look, told them to scram, not to come back. Great story! Well, the years have come and gone, and in his collection, Jim presently has a '40 Ford pickup and a '40 Ford convertible. He also has a '72 Pantera he's working on, so stay tuned for that one! **Jerry Case:** Jerry grew up in the music world and became a professional musician at a very young age. But he was always curious how things work, which led to a strong interest in cars. So until Jerry was in his 40's, music paid his bills, and cars were a hobby. He'd bring old derelicts home, fix 'em, and sell them. But there came a point in his work-life when that changed: Working on cars in high-end repair shops for the likes of Dick Scritchfield and such, became more lucrative than working in the music industry. At that point, things flip-flopped: Cars paid the bills and music became a hobby! In the 1970's, Jerry restored a '47 pickup. Now he's working on a '47 Ford Sedan Delivery, says it's almost finished. He shared a great story about a mishap late one night as he was returning from a music gig. Wrong place, wrong time, yep, he got rear-ended by a guy who was doing 60 mph. The impact pushed him into a pole, and he woke up in the emergency room with his guitar beside him! Turns out that someone had picked it up and put it in the ambulance beside him. A true good samaritan that Jerry was really grateful for.

So that was our Program. Interesting People we rub shoulders with in our Club! Thanks, fellows, we all appreciated!

Vasken: Announced Upcoming Events. Among them was the **Big Three Auto Parts Exchange** in San Diego. This is the last year for this Swap Meet, they're tearing down Qualcomm stadium where it's held.

Raffle: Handled by Joe DiFatta. Many winners took home some nice prizes. Thanks, Joe, for handling.

Vasken: Announced next Club meeting, Tuesday Feb 6, same place: Rosie's Barbecue & Grillery. Reminder: Board of Directors meeting Thursday Jan.18, 6 pm, at the Boskovich residence.

Hello My Fellow DriveLiners
Allow Me to introduce Myself
I am proud to be the new editor of the DriveLines Newsletter
My Name is
Robert, the "MadModelr" Glucksman
My company is
Models Unlimited / R.H. Factor Graphics

I have been a Car enthusiast ever since I drove the hell out of My Dads 61 Corvair at 3 years old, in his lap. But I showed the parking lot who was the boss

I have a long background in the graphics & printing industry, as well as a 40 year career in building Scale Models

I am currently the proud owner of a 55 Ford Mainline survivor that was purchased from a fellow club member

This Newsletter belongs to You, the members of this club. It is My intent to continue in the spirit that has been, and yet to enhance and expand what We have. I will try to be accessible and open

I would like for You folks to send Me pic's of you with your cars, and maybe a short story

Thank You

Robert

madmodelr@aol.com

FROM THE PRESIDENT.

HAPPY VALENTINES DAY, HAPPY PRESIDENTS DAY, HAPPY CHINESE NEW YEAR, ST. VALENTINES DAY, AND ASH WEDNESDAY.

WE HAD A GREAT MEETING IN JANUARY, CONSIDERING THE SECOND DAY OF THE NEW YEAR. WE MET THE NEW OWNER OF ROSIE'S, AND HE SAID HE WILL HELP OUR CLUB.

IT WAS GOOD TO SEE CHUCK, UP AND RUNNING AT FULL THROTTLE.

WE HAD A BOARD OF DIRECTORS MEETING ON JANUARY 18TH AT STEVE AND SUE'S HOME, THANK YOU STEVE AND SUE FOR OPENING YOUR HOME FOR US.

WE DISCUSSED MANY ISSUES, VERY GOOD INPUT FROM THE BOARD MEMBERS.

1. HOW TO INCREASE OUR MEMBERSHIP, AND TO GET OUR MEMBERS MORE INVOLVED WITH OUR CLUB.

2. STARTING MARCH, IT WILL COST YOU 25 CENTS IF YOU FORGET YOUR NAME BADGE. YES WE ARE RAISING MONEY TO BUY ROSIE'S BBQ.

3. JULY MEETING IS MOVED FROM JULY 3RD. TO JULY 11TH.

MANY OTHER TOPICS WERE DISCUSSED, LIKE THE CHRISTMAS DINNER, FINANCES, TOURS, GUEST SPEAKERS, ETC. I WILL TALK ABOUT THEM AS WE GO.

FROM THE NATIONALS, PHIL HALL SAID, THE MEMBERSHIP IS DECLINING ACROSS NATIONALLY, AND LOCALLY. IT IS NOT JUST OUR CLUB SUFFERING WITH MEMBERSHIP, BUT ALL CLUBS ALSO. AGE AND HEALTH ARE THE BIG FACTORS.

WE ARE A FAMILY OF CARS, THERE ARE MANY OTHER CAR CLUBS, CAR FAMILIES, AND WE HAVE TO KEEP THE TORCH LIT, AS LONG AS WE CAN.

AS YOU KNOW MOST OF THE YOUNGSTERS ARE NOT INTERESTED IN OUR CARS, OR THE LOVE WE HAVE FOR CARS.

IT IS VERY HARD TO SELL A CLASSIC CAR TODAY, WITHOUT REDUCING THE PRICE BELOW YOUR INVESTMENT, AND TAKING A LOSS.

THE FUTURE FOR OUR CLASSIC CARS ARE THE GRAND KIDS INHERITING THEM. TEACH THEM HOW TO DOUBLE CLUTCH, OR 1ST GEAR HAS NO SYNCHRO.

MY GRAND KID WILL HAVE MY CLASSIC CAR(S) IN THE FRONT LAWN ON THE FIRST SATURDAY AND DUMP IT, TO BUY THE NEWEST COMPUTER, CELL PHONE, OR??

PLEASE DO NOT KNOCK THE CAR, OR THE DRIVER, WHEN THEY DRIVE A STUDEBAKER, RAMBLER, DODGE, CHEVY, OR? SUPPORT THEM, GIVE THEM A PAT IN THE BACK.

NICE CAR, WHAT COLOR IS THE PAINT? MOTOR? WE ARE IN THE SAME FAMILY, LIKE BROTHERS AND SISTERS.

PLEASE PUT AN EFFORT TO BRING A FRIEND TO OUR MEETING, LET US WORK ON INCREASING OUR MEMBERSHIP.

HAPPY VALENTIN'S DAY.

VASKEN HAGOPIAN